

E-5189

Peso: 730 gr/m.
P. Total: 210 mm.

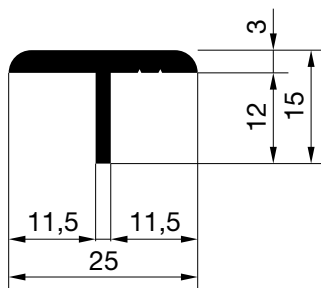

E-5196

Peso: 257 gr/m.
P. Total: 76 mm.

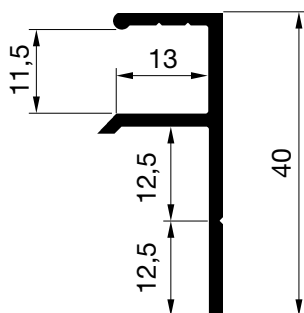

E-5924

Peso: 278 gr/m.
P. Total: 140 mm.

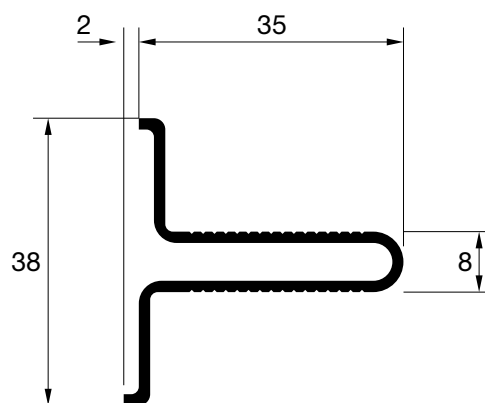

E-5743

Peso: 400 gr/m.
P. Total: 213 mm.

PERFILES AUTOCARES Y AUTOBUSES



HYDRO

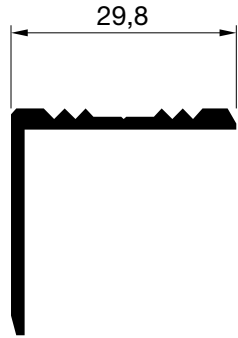

E-5675
Peso: 294 gr/m.
P. Total: 123 mm.

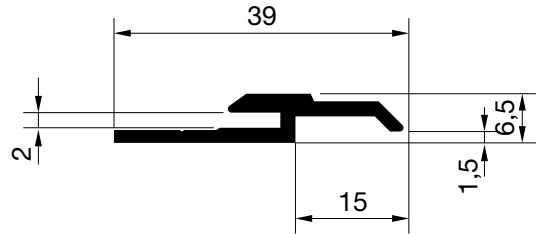

E-5273
Peso: 260 gr/m.
P. Total: 102,3 mm.

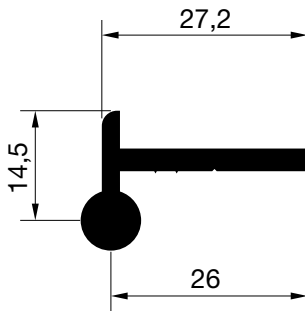

E-3603
Peso: 403 gr/m.
P. Total: 96 mm.

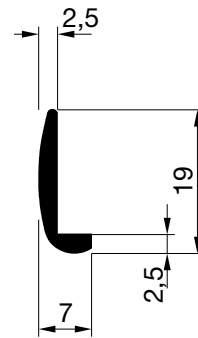

E - 5646
Peso: 126 gr/m.
P. Total: 47 mm.

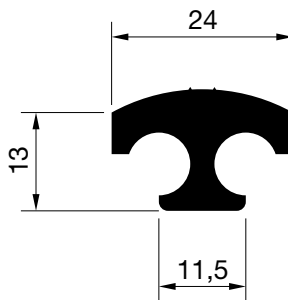

E-3604
Peso: 537 gr/m.
P. Total: 92 mm.

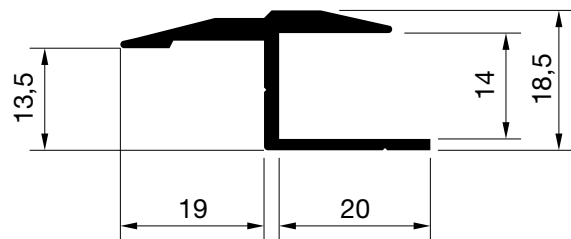

E-3601
Peso: 392 gr/m.
P. Total: 146 mm.

PERFILES AUTOCARES Y AUTOBUSES



HYDRO

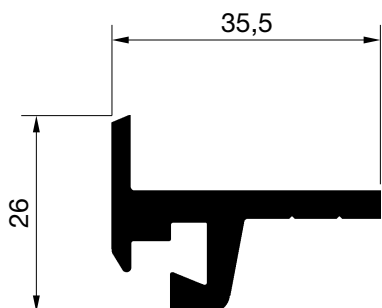

E-5036

Peso: 673 gr/m.
P. Total: 143 mm.

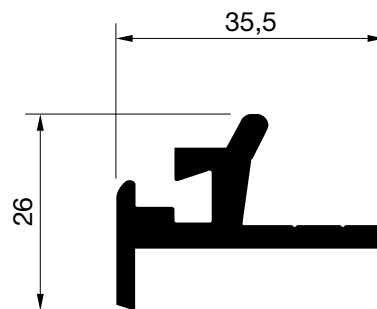

E-5037

Peso: 806 gr/m.
P. Total: 165 mm.

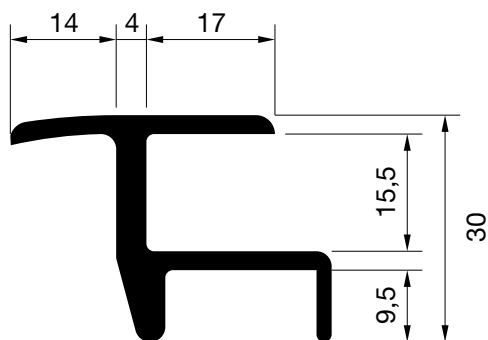

E-5038

Peso: 761 gr/m.
P. Total: 190 mm.

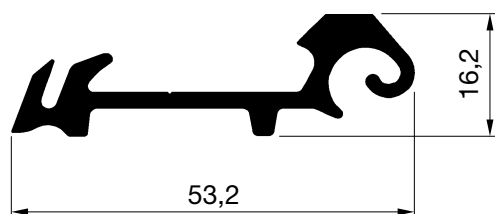

E-4867

Peso: 613 gr/m.
P. Total: 188 mm.

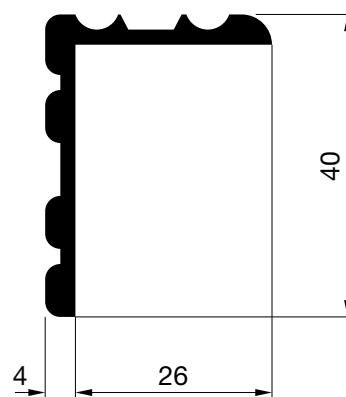

E-0051

Peso: 527 gr/m.
P. Total: 195 mm.

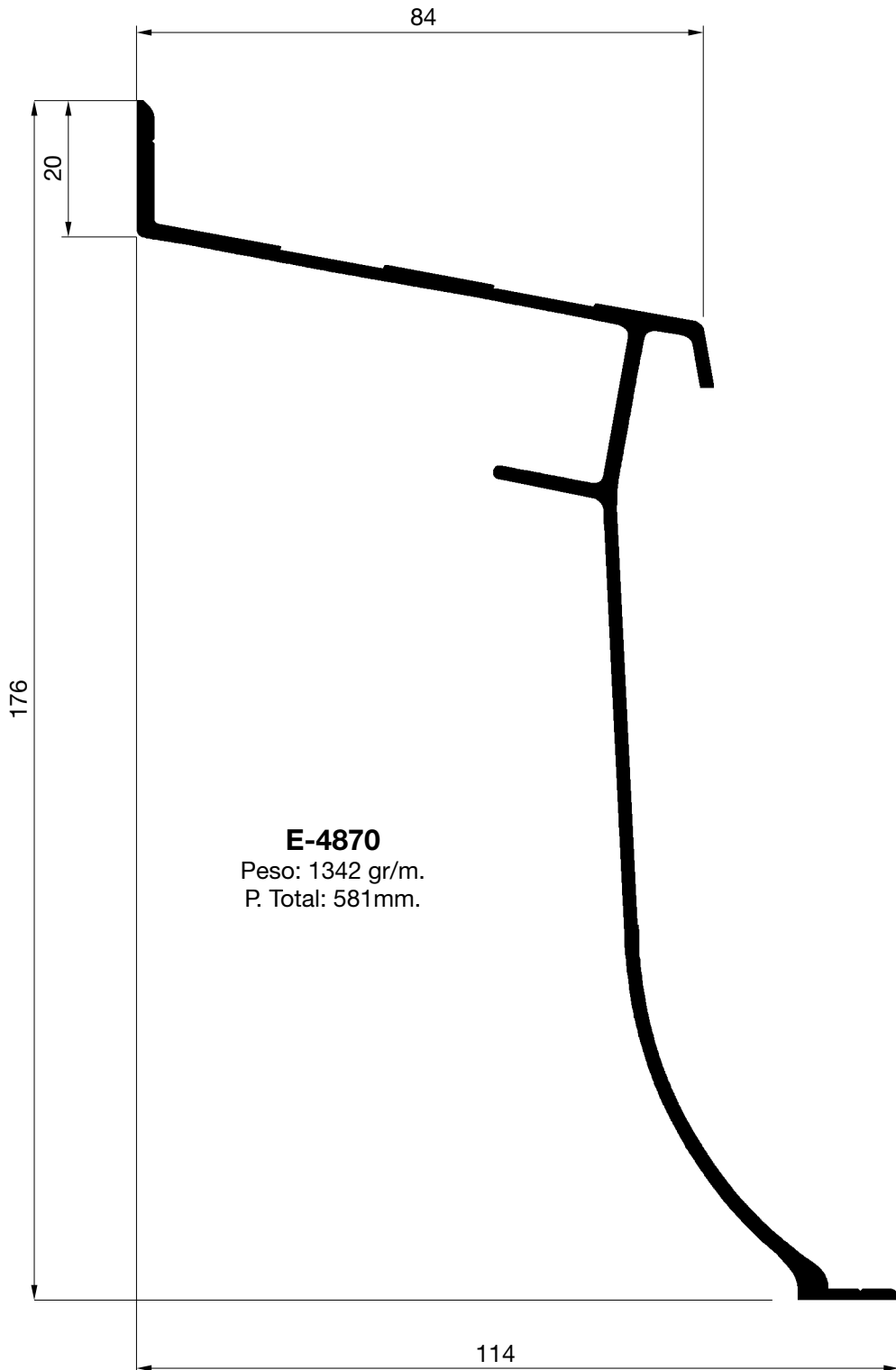

E-4870
Peso: 1342 gr/m.
P. Total: 581mm.

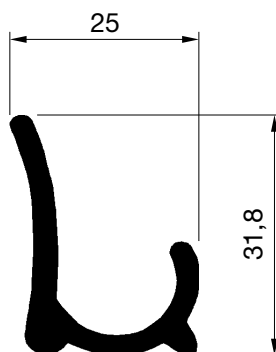

E-0072

Peso: 374 gr/m.
P. Total: 132 mm.

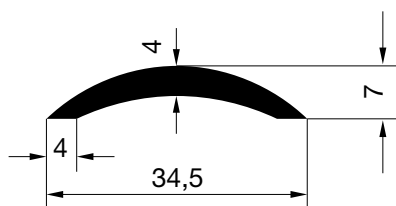

E-1458

Peso: 304 gr/m.
P. Total: 74 mm.

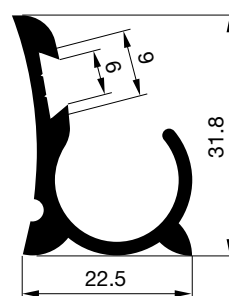

E-0070

Peso: 453 gr/m.
P. Total: 147 mm.

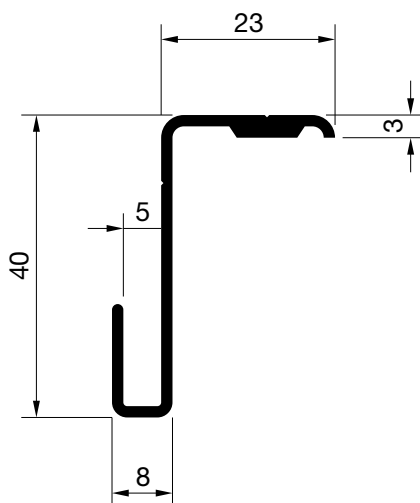

E-1670

Peso: 354 gr/m.
P. Total: 164 mm.

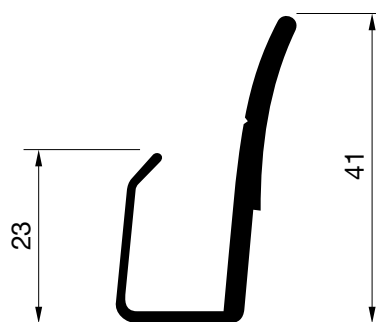

E-3086

Peso: 534 gr/m.
P. Total: 160 mm.

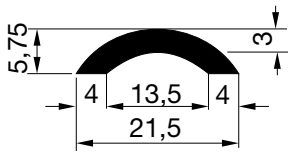

E-7480

Peso: 165 gr/m.
P. Total: 49 mm.

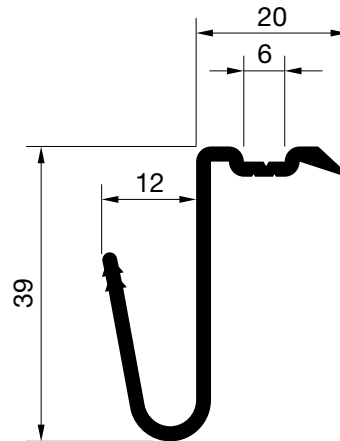

E-3234

Peso: 469 gr/m.
P. Total: 182 mm.

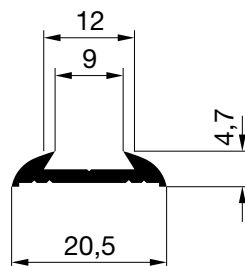

E-1861

Peso: 132 gr/m.
P. Total: 43 mm.

PERFILES AUTOCARES Y AUTOBUSES



HYDRO

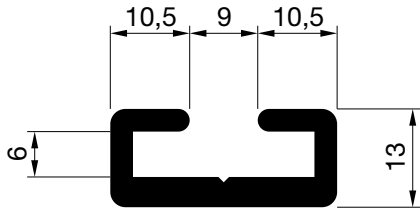

E-3491

Peso: 575 gr/m.
P. Total: 129 mm.

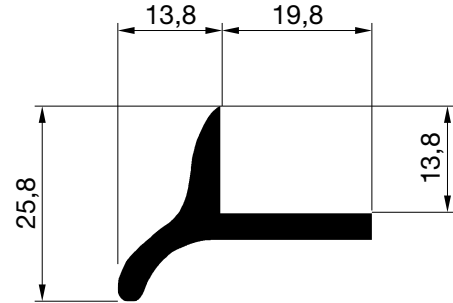

E-0022

Peso: 420 gr/m.
P. Total: 110 mm.

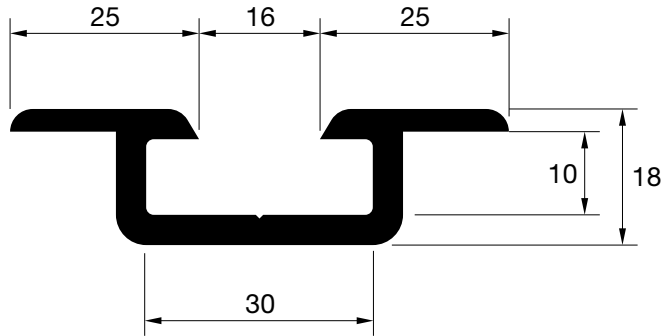

E-3123

Peso: 1033 gr/m.
P. Total: 213 mm.

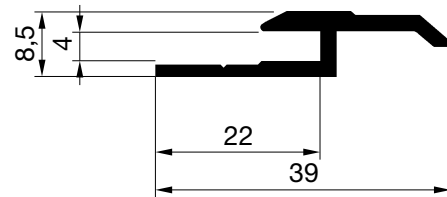

E-3597

Peso: 277 gr/m.
P. Total: 110 mm.

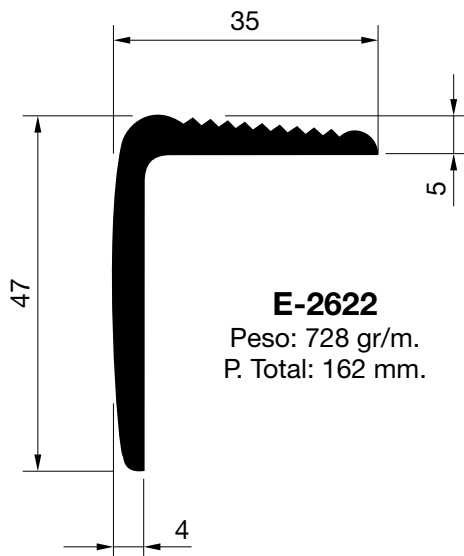

E-2622

Peso: 728 gr/m.
P. Total: 162 mm.

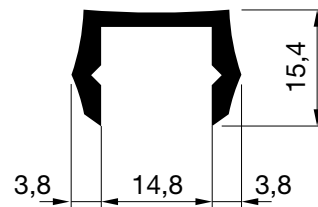

E-2531

Peso: 290 gr/m.
P. Total: 97 mm.

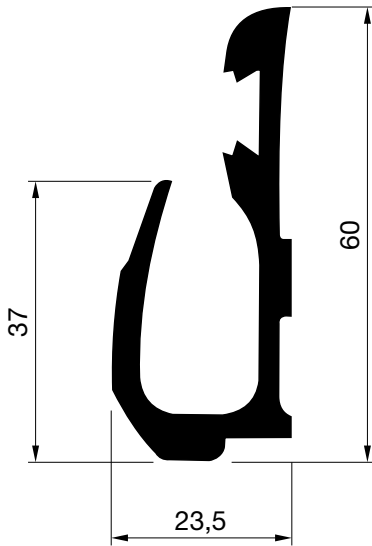

E-4754
Peso: 1105 gr/m.
P. Total: 239 mm.

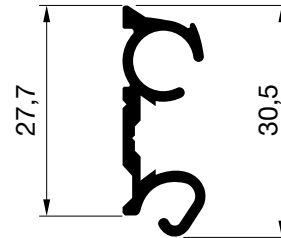

E-2046
Peso: 245 gr/m.
P. Total: 124 mm.

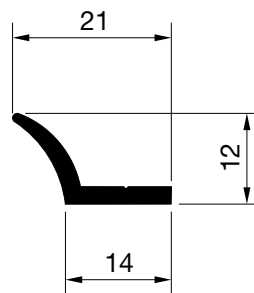

E-4232
Peso: 141 gr/m.
P. Total: 57 mm.

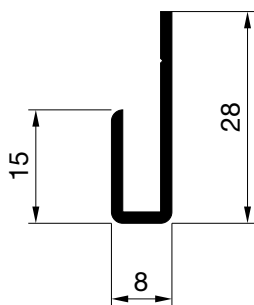

E-3775
Peso: 794 gr/m.
P. Total: 98 mm.

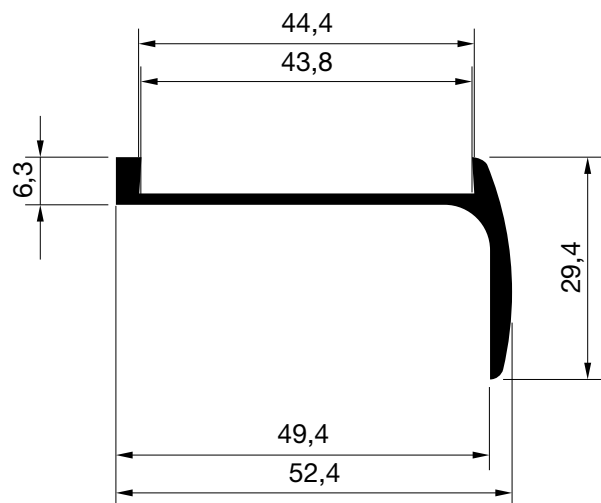

E-4011
Peso: 454 gr/m.
P. Total: 166 mm.

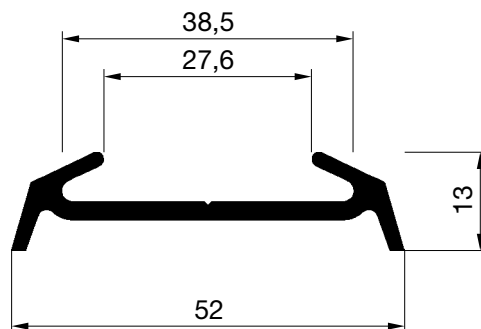

E-1700

Peso: 494 gr/m.
P. Total: 174 mm.

30

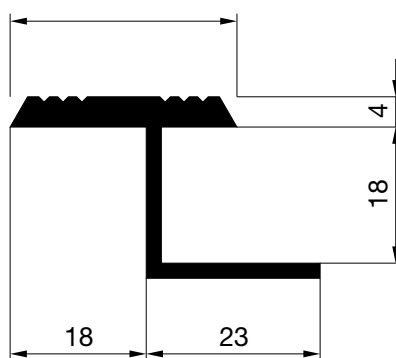

E-3746

Peso: 513 gr/m.
P. Total: 161 mm.

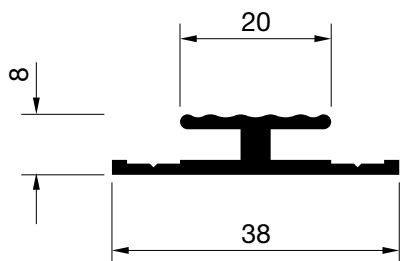

E-1646

Peso: 323 gr/m.
P.Total: 126 mm.

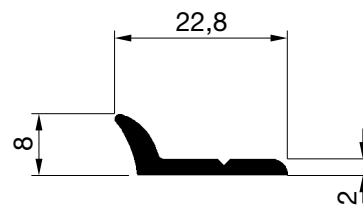

E-1632

Peso: 150 gr/m.
P. Total: 54 mm.

PERFILES AUTOCARES Y AUTOBUSES



HYDRO

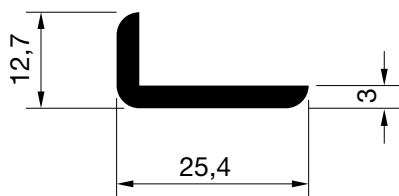

E-1703

Peso: 270 gr/m.
P.Total: 72 mm.

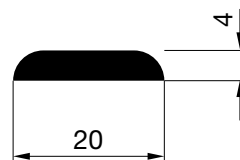

E-1268

Peso: 197 gr/m.
P. Total: 44 mm.

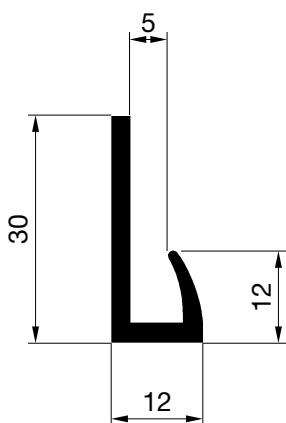

E-1719

Peso: 310 gr/m.
P. Total: 104 mm.

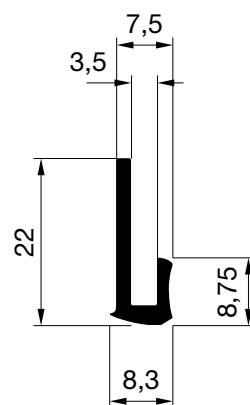

E-1200

Peso: 178 gr/m.
P. Total: 71 mm.

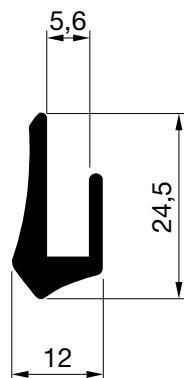

E-1245

Peso: 297 gr/m.
P. Total: 86 mm.

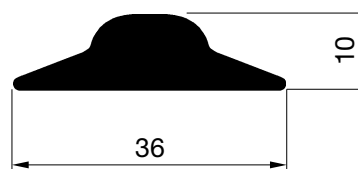

E-1305

Peso: 567 gr/m.
P. Total: 78 mm.

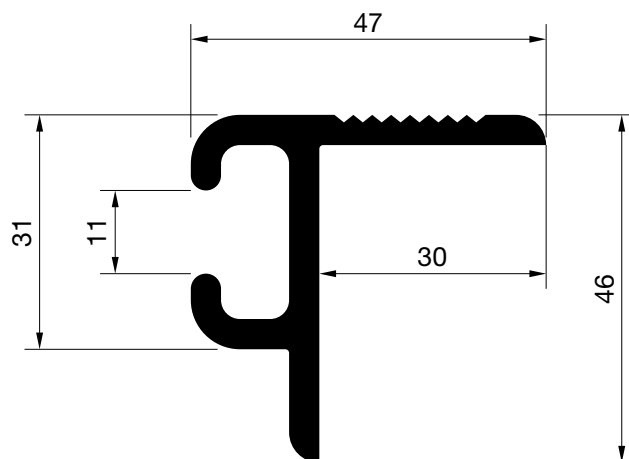

E-1244

Peso: 1142 gr/m.
P. Total: 224 mm.

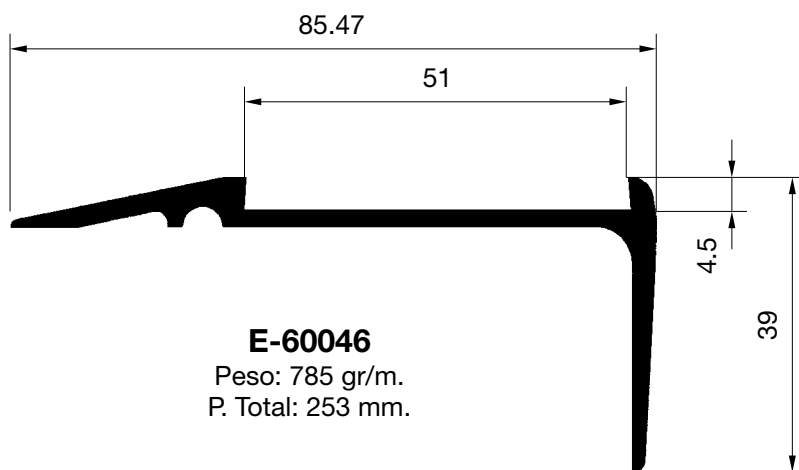

E-60046

Peso: 785 gr/m.
P. Total: 253 mm.