

Hydro

UNIT

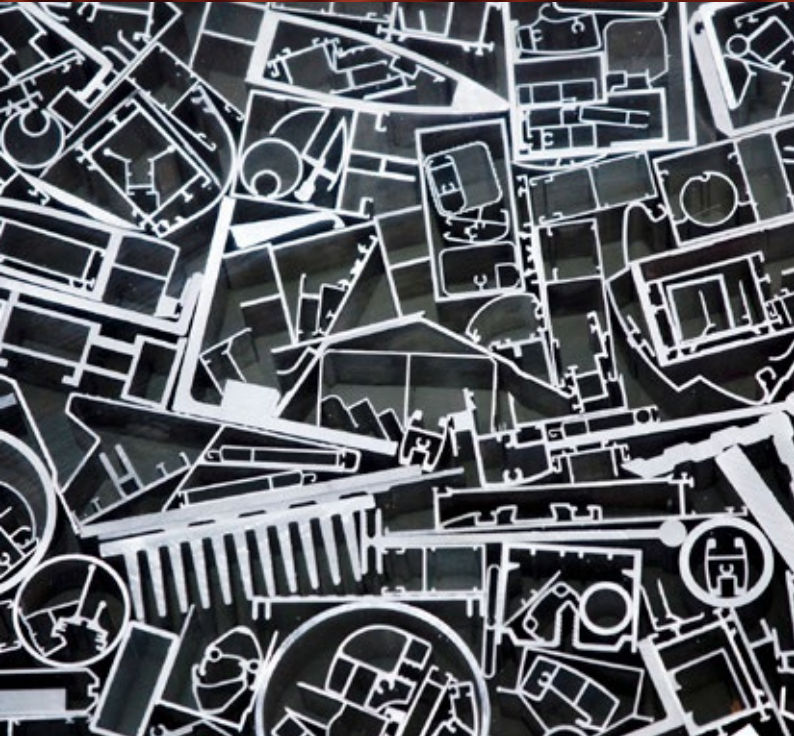



Hydro – A empresa de energia e alumínio

A Hydro é uma líder industrial que constrói negócios e parcerias para um futuro mais sustentável. Desenvolvemos indústrias que fazem a diferença para as pessoas e para a sociedade. Desde 1905, a Hydro transforma recursos naturais em produtos e negócios relevantes para as pessoas, criando um local de trabalho seguro e protegido para nossos 31.000 empregados*, em mais de 140 unidades, em 40 países. Hoje, possuímos e operamos vários negócios, além de investirmos em indústrias sustentáveis.

A Hydro, por meio de seus negócios, está presente em uma ampla gama de segmentos do mercado de alumínio, energia, reciclagem de metais, energias renováveis e baterias, oferecendo conhecimentos e competências únicas.

A Hydro está comprometida em liderar o setor na criação de um futuro mais sustentável, criando sociedades mais viáveis ao desenvolver recursos naturais em produtos e soluções de maneiras inovadoras e eficientes.

*Informação referente a data de fechamento do material.

Hydro Bauxita & Alumina

A Hydro Bauxita & Alumina inclui uma das maiores minas de bauxita do mundo e a maior refinaria de alumina fora da China, ambas no Brasil, representando dois elos importantes na cadeia de produção do nosso alumínio. Nossos mais de 4.000 empregados* trabalham nos escritórios do Brasil, na mina de Paragominas e na refinaria de alumina em Barcarena, no norte do país. Além disso, comercializamos alumina para clientes externos.

Hydro Energia

A Hydro Energia tem mais de 100 anos de experiência em energia hidrelétrica, sendo uma das três maiores operadoras de produção de energia na Noruega e empregando 200 pessoas*. Além disso, estamos envolvidos com energia eólica na Noruega e temos uma participação importante no mercado de energia na região nórdica e no Brasil.



Hydro Extrusão

A Hydro Extrusão é uma empresa líder mundial em extrusão de alumínio, com cerca de 100 unidades de produção, em 40 países, e empregando 20.000 pessoas*. Por meio de uma combinação exclusiva

de experiência local, rede global e recursos de P&D incomparáveis, podemos oferecer desde perfis padronizados até desenvolvimento e fabricação avançados para a maioria das indústrias.



Portfólio Hydro

Para todos os tipos e padrões de obras.

Sistemas
Comerciais

ECO 
FAÇADE

 CITTÀ

UNIT

 ELEGANCE
MIRROR

WIND
FAÇADE 

Sistemas
Residenciais

UNICA

UNICA
MINIMALIST

INOVA

 PRODUTIVA25

GOLD Slim

NOVA
GOLD 

 MASTER

Complementos
de Arquitetura

 ESPLENDOOR

UNIVERSAL
VARANDA E GRADIL

SKYLINE

UNIVERSAL
PORTÃO E GRADE

UNIVERSAL
BRISE



UNIT

Unit

O ritmo atual das construções demanda produtos de alta qualidade, facilidade de fabricação, rapidez na instalação e ótimo desempenho técnico. O sistema Unit foi desenvolvida para atender esta demanda. Trata-se de um sistema para fachadas-cortina e entre-vãos modulados, prático e de elevada produtividade. Sua inspiração vem no

conceito americano de unitized systems com uma ampla gama de opções de montagem que ainda podem ser adaptadas às necessidades específicas de cada projeto. O alto desempenho se apresenta em relação a integridade estrutural e excelente vedação ao ar e a água. O resultado final é uma excelente relação custo x benefício.

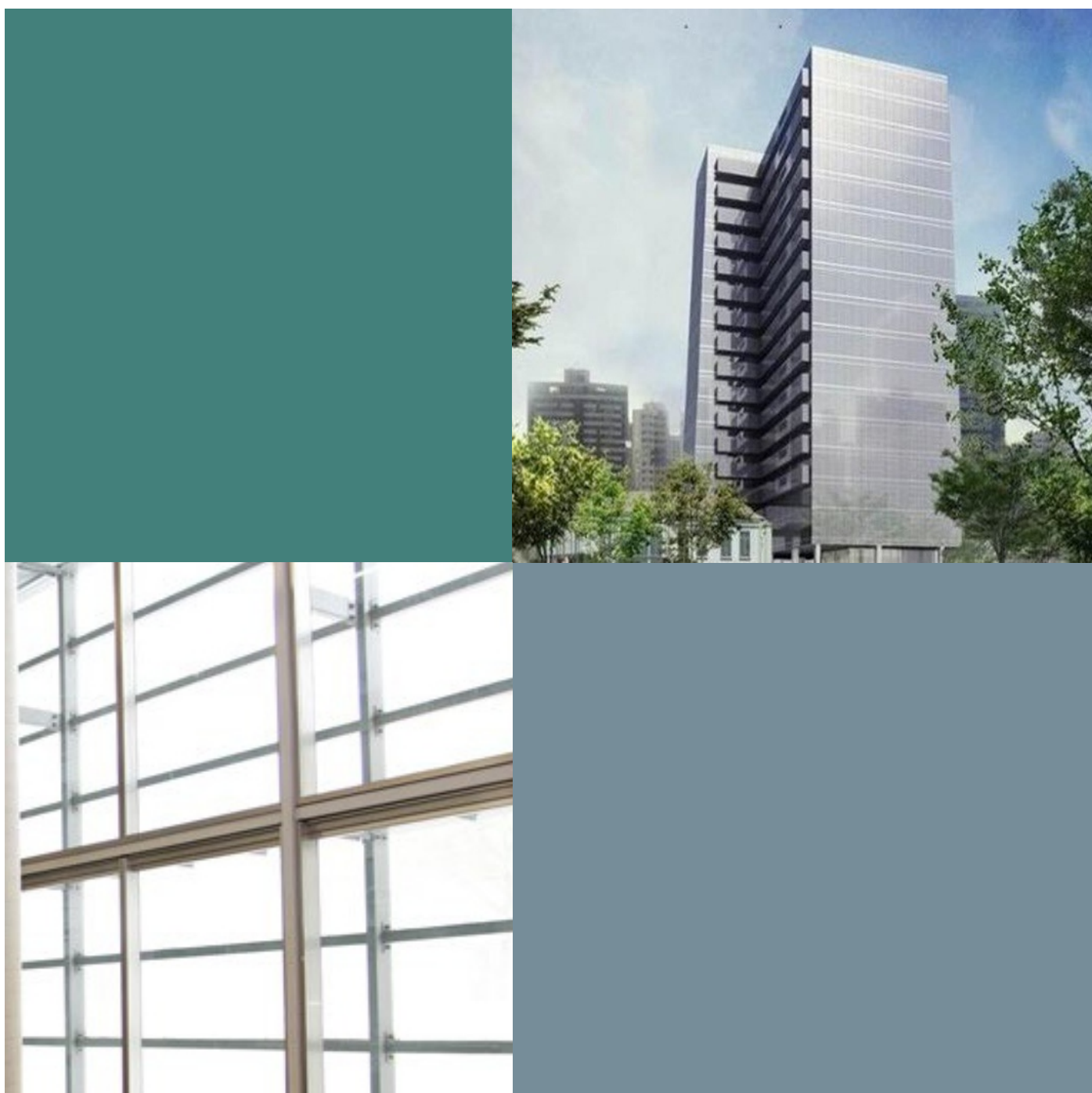

Normas	B-01 - B-05
Resultado de Ensaios	C-01
Tipologias	D-01 - D-02
Módulo 60-25	E-01 - E-05
Módulo 80-25	F-01 - F-05
Módulo 80-35 Rebaixo	G-01 - G-05
Módulo 80-35	H-01 - H-05
Módulo 80-35R	I-01 - I-09
Módulo 100 Encaixilhado	J-01 - J-06
Módulo 120	K-01 - K-05
Módulo 120-35	L-01 - L-05
Módulo Fachada 80	M-01 - M-08
Módulo Fachada 100	N-01 - N-09
Módulo Fachada 127	O-01 - O-11
Módulo Anc. Telescópica	P-01 - P-12
Módulo Fachada Extrema	Q-01 - Q-04
Perfis Diversos	R-01 - R-18
Esquema de Montagem	S-01
Componentes	T-01 - T-06
Usinagens	U-01 - U-42
Detalhes Construtivos	V-01 - V-58

NORMA ABNT NBR 10821-2017

A norma ABNT NBR 10821/17 estabelece os parâmetros mínimos de desempenho bde esquadrias localizadas na face externa das edificações de uso comercial ou residencial, em todo o Brasil. Esta norma abrange os seguintes pontos:

- Permeabilidade ao ar;
- Estanqueidade à água;
- Resistência às cargas uniformemente distribuídas (cargas de vento);
- Resistência às operações de manuseio

Quando falamos de resistência às cargas uniformemente distribuídas, esta norma nos traz um mapa de isopletras do Brasil, retirado da norma ABNT NBR 6123, em que encontramos a velocidade dos ventos, através da qual conseguimos calcular as forças devidas ao vento.

MAPA DE VELOCIDADE DO VENTO POR REGIÃO NO BRASIL

A velocidade do vento é o parâmetro inicial para calcularmos a pressão do vento no local desejado, além disso deve-se levar em conta, ainda, a altura do edifício, rugosidade do terreno, densidade de construções no entorno, topografia, forma geométrica do

edifício, entre outras características. Para facilitar, a NBR 10821/17 já traz a seguinte tabela, que determina as pressões de ensaio, de segurança e de água em edifícios de até 30 pavimentos ou 90 metros de altura para todas as regiões do Brasil.

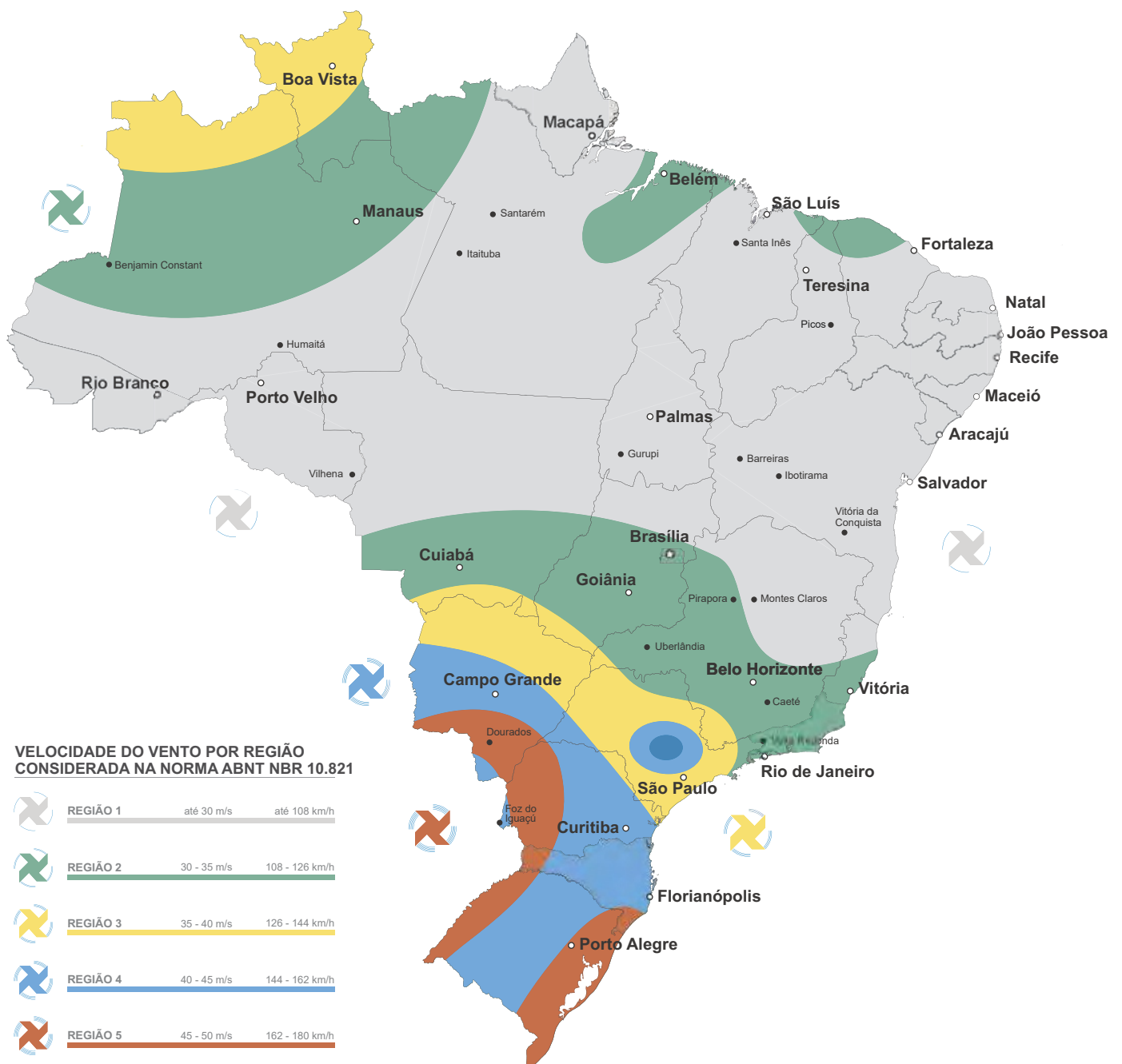

É importante destacar que esta tabela não é válida para:

- Edificações em que a esquadria não seja instalada na posição vertical;
- Edificações de formas não retangulares;
- Edificações com localização, especificação, necessidade e exigências especiais de utilização;
- Quando houver túnel de vento.

Para os três primeiros casos, as pressões devem ser calculadas de acordo com a norma NBR 6123 / 13. Caso seja encontrado um valor menor do que o que consta na tabela abaixo, deve-se prevalecer a maior pressão.

Valores de pressão do vento conforme a região do país e o número de pavimentos da edificação

Quantidade de pavimentos	Altura Máxima	Regiões do País	Pressão do ensaio Pe em (Pa) Positiva e negativa Pe = pp x 1,2	Pressão de segurança Ps em (Pa) Positiva e negativa Ps = pe x 1,5	Pressão de água Pa em (Pa) Positiva e negativa Pa = Pp x 0,2
02	6 m	I	350	520	60
		II	470	700	80
		III	610	920	100
		IV	770	1160	130
		V	950	1430	160
05	15 m	I	420	640	70
		II	580	860	100
		III	750	1130	130
		IV	950	1430	160
		V	1180	1780	200
10	30 m	I	500	750	80
		II	680	1030	110
		III	890	1340	150
		IV	1130	1700	190
		V	1400	2090	230
20	60 m	I	600	900	100
		II	815	1220	140
		III	1060	1600	180
		IV	1350	2020	220
		V	1660	2500	280
30	90 m	I	660	980	110
		II	890	1340	150
		III	1170	1750	200
		IV	1480	2210	250
		V	1820	2730	300

Começando da esquerda para a direita temos, na primeira coluna, a quantidade de pavimentos; na segunda, a altura máxima da edificação; na terceira, a região definida pelo mapa de isopletras (velocidades do vento); na quarta, a pressão de ensaio dada em Pascal; na quinta, a pressão de segurança dada em Pascal; e na sexta a pressão de água dada em Pascal.

Na quinta coluna, apresenta-se a pressão de segurança. Esta pressão foi estabelecida para verificar casos extremos que a esquadria deve suportar. Durante o ensaio, não se exige a medição da flecha provocada, mas a verificação de que não houve colapso total ou parcial de qualquer dos componentes da esquadria, incluindo o vidro.

Logo, é importante considerar o desempenho dos vidros durante o cálculo. Como colapso entende-se qualquer alteração vital no funcionamento do conjunto, sua estrutura ou componentes, que coloque em risco os usuários ou terceiros.

Para ilustrar, veja o exemplo abaixo:

Gráfico Linha Unit 80 - Entre-vãos

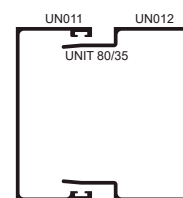
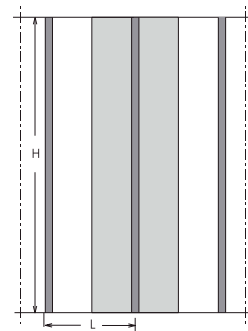
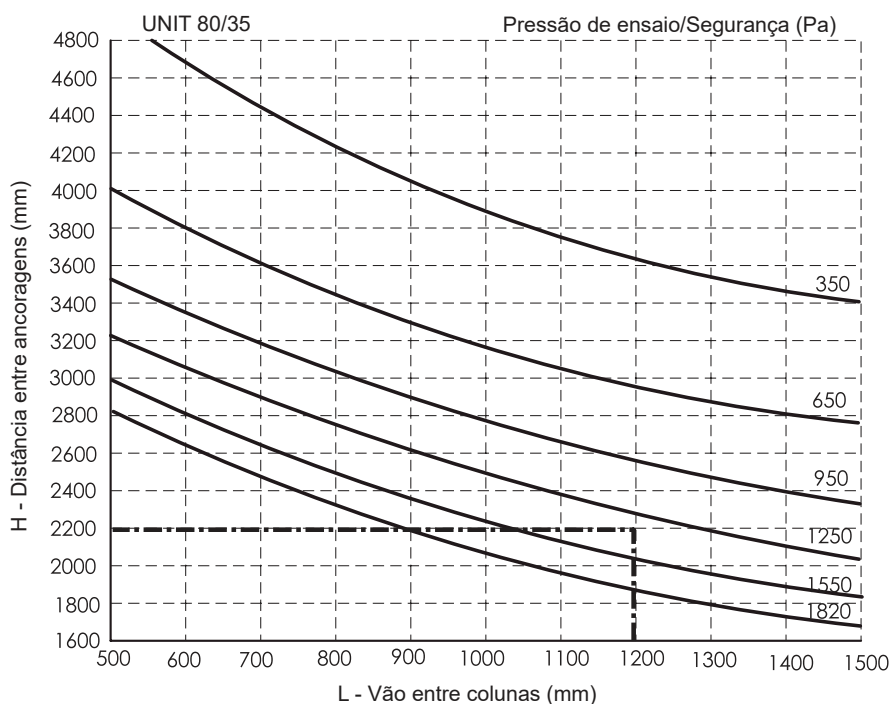

Área = 653 mm²
 Jx = 670906 mm⁴
 Wx = 16143 mm³
 H = 83 mm

Tensão Admissível = 7 Kg / mm² (liga 6060 T5)

Flecha Admissível = H / 175 ou 30 mm

O gráfico abaixo apresenta as Pressões de Ensaio e de Segurança da Linha Unit Hydro – Módulo 80, na condição entre vão, coluna tipo macho e fêmea, considerada bi apoiada, sendo que a curva contempla os requisitos das colunas 4 e 5 simultaneamente, tendo como dado de entrada os valores da coluna 4.

Analise o caso de janela de 1200 mm de largura e vamos ver com qual altura e em quais regiões ela pode ser aplicada:

Caso A- Ok para 2000 mm de altura na região V, em edifícios de até 90 metros de altura.

Caso B- Ok para 2200 mm de altura na região IV, em edifícios de até 90 metros de altura.

Caso C- Ok para 2400 mm de altura na região III, em edifícios com até 30 pavimentos, ou 90 metros de altura.

Em resumo, diminuindo-se a pressão é possível aumentar a altura da esquadria com a mesma construção.

É importante destacar que a tabela não é válida para:

- Edifícios em que a esquadria não seja instalada na posição vertical;
- Edifícios de forma não retangular;
- Edifícios com especificações, localização, necessidades e exigências especiais de utilização.

Nestes casos, a pressão de Ensaio e de segurança devem ser calculadas de acordo com a NBR 6123 / 11, podendo contar com parâmetros obtidos em ensaio de túnel de vento. Caso encontre-se um valor menor do que consta na tabela 1, fica valendo o maior, de acordo com a NBR 10.821 / 11.



4. RESULTADOS OBTIDOS

4.1. Verificação da penetração de ar

DETERMINAÇÃO DA VAZÃO DE AR	
Vazão de Alimentação Q_a (m ³ /h)	154
Vazão de Ar Q (m ³ /h)	158
Vazão de Permeabilidade Q_p ($Q_p = Q - Q_a$)	4 (m ³ /h)
CÁLCULO DA VAZÃO POR METRO LINEAR DE JUNTAS ABERTAS	
Comprimento de Juntas Abertas (m)	9,60
Vazão de Permeabilidade por metro linear ($Q_p +$ Comprimento de Juntas Abertas)	0,42
Classificação de acordo com Anexo B da NBR 10821-2	Superior
CÁLCULO DA VAZÃO POR ÁREA TOTAL DO VÃO	
Área do vão (m ²)	24,70
Vazão de Permeabilidade por área total do vão ($Q_p +$ Área Total do Vão)	0,16
Classificação de acordo com Anexo B da NBR 10821-2	Superior

4.2. Verificação da estanqueidade à água – Método A (esquadrias totalmente expostas.)

Conforme solicitação do interessado, o ensaio foi realizado considerando como pressão de ensaio o valor de 300 Pa.

Pressão de Ensaio (Pa)	Período de Aplicação (min.)	Ocorrências
0	15	Nenhuma ocorrência de infiltração de água.
20	05	
40	05	
60	05	
80	05	
100	05	
120	05	
150	05	
180	05	
210	05	
240	05	
270	05	
300	05	

Seguem definições de acordo com a NBR 10821-3:2011, itens 3.7 e 3.8:

Permeabilidade Inicial (PI): Início de vazamento de água no interior da esquadria ou das partes, ocorrido a qualquer tempo, desde que a água não ultrapasse o plano do marco da esquadria, sem molhar o peitoril da alvenaria ou a face interna da parede.

Permeabilidade Excessiva (PE): Todo e qualquer vazamento de água que ultrapasse o plano do marco da esquadria. Neste caso a esquadria é reprovada.





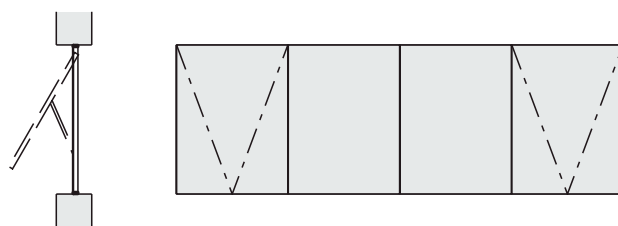
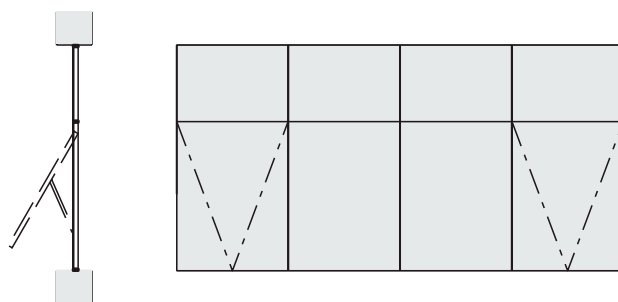
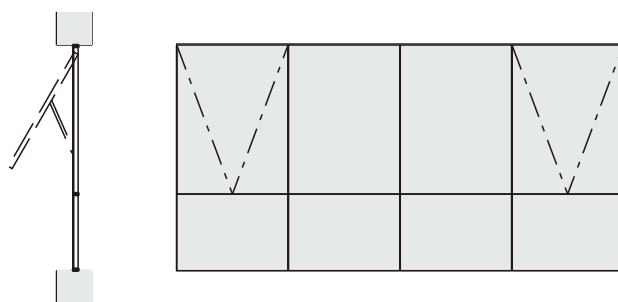



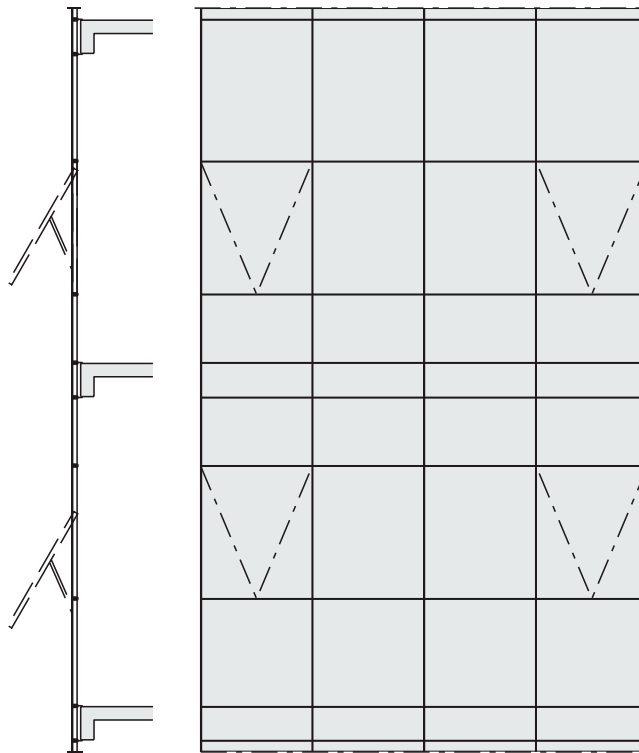







De acordo com a tabela 2 da NBR 10821-2:2011 de níveis de desempenho das esquadrias quanto ao seu uso, no ensaio de verificação da estanqueidade à água o protótipo classifica-se como Superior.













MÓDULOS ENTRE-VÃOS

















MÓDULOS FACHADAS



Código	Perfil	Peso (Kg/m)	Pag.
MÓDULO - 60			
UN178		0,756	E-05
UN319		1,016	E-05
UN320		0,823	E-05
UN321		0,789	E-05
UN322		0,600	E-05
UN323		1,160	E-05
UN343		0,439	E-05
UN355		1,799	E-05
MÓDULO - 80-35 R			
UN002		0,887	I-07
UN432		1,862	I-08
UN431		1,693	I-08
UN332		1,108	I-07
UN328		1,033	I-07
UN329		1,206	I-07
UN025		1,022	I-08
UN433		1,875	I-09

Código	Perfil	Peso (Kg/m)	Pag.
MÓDULO - 80-35 R			
UN434		1,723	I-09
UN330		1,527	I-07
MÓDULO - 80-35 Rebaixo			
UN002		0,887	G-05
UN011		0,790	G-04
UN012		0,976	G-04
UN032		0,563	G-04
UN060		1,018	G-05
UN085		0,953	G-05
UN087		0,620	G-04
UN328		1,033	G-05
UN357		1,262	G-04
UN358		0,639	G-04

Código	Perfil	Peso (Kg/m)	Pag.
MÓDULO - 80-35			
UN002		0,887	H-04
UN011		0,790	H-04
UN012		0,976	H-04
UN013		1,196	H-05
UN016		1,551	H-05
UN328		1,033	H-04
UN332		1,108	H-04
UN356		2,062	H-05
MÓDULO - 80-25			
UN002		0,887	F-05
UN324		0,944	F-05
UN332		1,108	F-05
UN325		0,884	F-05
UN326		0,689	F-05
UN356		2,062	F-05

Código	Perfil	Peso (Kg/m)	Pag.
MÓDULO - 100 ENCAIXILHADO			
UN106		1,620	J-05
UN107		1,377	J-05
UN108		1,169	J-05
UN109		1,130	J-05
UN110		1,916	J-06
UN111		3,254	J-06
UN112		0,384	J-06
UN113		1,208	J-05
UN114		0,503	J-05
UN115		0,533	J-06
UN116		0,542	J-06
UN118		0,414	J-06
FC693		0,446	J-06

Código	Perfil	Peso (Kg/m)	Pag.
MÓDULO - 100 ENCAIXILHADO			
UN369		2,579	J-05
MÓDULO - FACHADA 80			
UN333		1,061	M-05
UN334		1,250	M-05
UN287		1,228	M-05
UN128		1,630	M-05
UN289		1,605	M-08
UN290		1,420	M-08
UN432		1,862	M-06
UN431		1,693	M-06
UN433		1,875	M-07
UN434		1,723	M-07
UN293		1,833	M-08
UN296		1,316	M-08
MÓDULO - FACHADA 100			
UN265		1,239	N-08

Código	Perfil	Peso (Kg/m)	Pag.
MÓDULO - FACHADA 100			
UN266		1,450	N-08
UN271		1,482	N-05
UN272		2,053	N-05
UN424		1,821	N-07
UN423		1,652	N-07
UN426		1,866	N-06
UN425		1,703	N-06
UN345		1,495	N-09
UN344		1,266	N-09
MÓDULO - TELESCÓPICO			
UN254		4,803	P-10
UN256		4,093	P-10
UN255		2,260	P-11
UN297		4,541	P-12
UN298		1,370	P-12
UN267		4,628	P-11

Código	Perfil	Peso (Kg/m)	Pag.
MÓDULO - FACHADA 127			
UN339		1,504	O-07
UN340		1,774	O-07
UN342		1,870	O-08
UN341		2,276	O-08
UN057		2,171	O-09
UN025		1,022	O-09
UN002		0,887	O-09
UN359		3,194	O-07
UN450		3,074	O-10
UN449		2,677	O-10
UN451		3,021	O-11
UN452		2,826	O-11

Código	Perfil	Peso (Kg/m)	Pag.
MÓDULO - FIXAÇÃO CONTÍNUA-120			
UN052		1,818	K-04
UN054		1,577	K-04
UN070		1,051	K-05 L-05
UN072		0,666	L-04
UN074		3,076	K-04 L-05
UN088		0,512	K-04
UN335		1,805	K-05 L-04
UN336		1,450	L-05
UN337		1,423	K-05 L-04
UN338		1,744	K-05 L-04
MÓDULO - UNI/EXTREMA			
UN230		2,268	Q-04
UN231		2,319	Q-04
UN232		0,467	Q-04
UN236		1,083	Q-04

Código	Perfil	Peso (Kg/m)	Pag.
MÓDULO - DIVERSOS			
UN248		0,523	R-01
UN371		0,685	R-01
UN250		0,642	R-01
UN251		0,623	R-01
UN286		0,682	R-01
UN218		2,041	R-02
UN221		1,890	R-02
UN222		1,859	R-02
UN283		1,130	R-02
UN273		1,863	R-03
UN282		1,236	R-03
UN327		1,267	R-03
UN241		0,545	R-03
UN299		1,315	R-04
UN284		1,148	R-04

Código	Perfil	Peso (Kg/m)	Pag.
MÓDULO - DIVERSOS			
UN370		0,810	R-01
UN279		1,332	R-05
UN311		1,646	R-06
UN210		1,561	R-06
UN354		0,901	R-06
UN017		2,676	R-07
UN019		1,315	R-07
UN028		3,421	R-07
UN129		3,672	R-07
UN235		1,511	R-07
UN029		4,200	R-08
UN048		7,828	R-08
UN098		5,044	R-08

Código	Perfil	Peso (Kg/m)	Pag.
MÓDULO - DIVERSOS			
UN142		5,346	R-08
UN187		4,975	R-09
UN229		7,208	R-09
UN281		9,621	R-09
UN100		0,894	R-10
UN360		1,384	R-10
UN362		2,232	R-10
UN361		1,813	R-10
UN363		2,598	R-10
UN268		1,965	R-10
UN364		0,890	R-10
UN280		5,961	R-10
UN099		2,507	R-11
UN105		2,832	R-11

Código	Perfil	Peso (Kg/m)	Pag.
MÓDULO - DIVERSOS			
UN208		3,252	R-11
UN242		4,374	R-11
UN435		1,742	R-12
UN004		0,303	R-13
UN015		0,580	R-13
UN018		0,176	R-13
UN027		0,570	R-13
UN032		0,563	R-13
UN056		0,407	R-13
UN058		0,393	R-13
UN030		0,187	R-14
UN059		0,427	R-14
UN436		1,857	R-12
UN428		1,832	R-12

Módulo 60-25

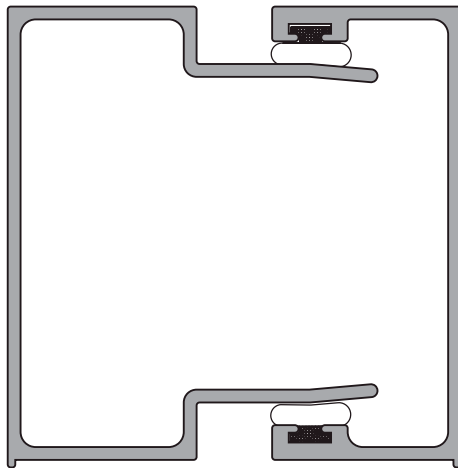

Montagem 60-25



Diagrama de Dimensões

UNIT - Módulo 60 - 25

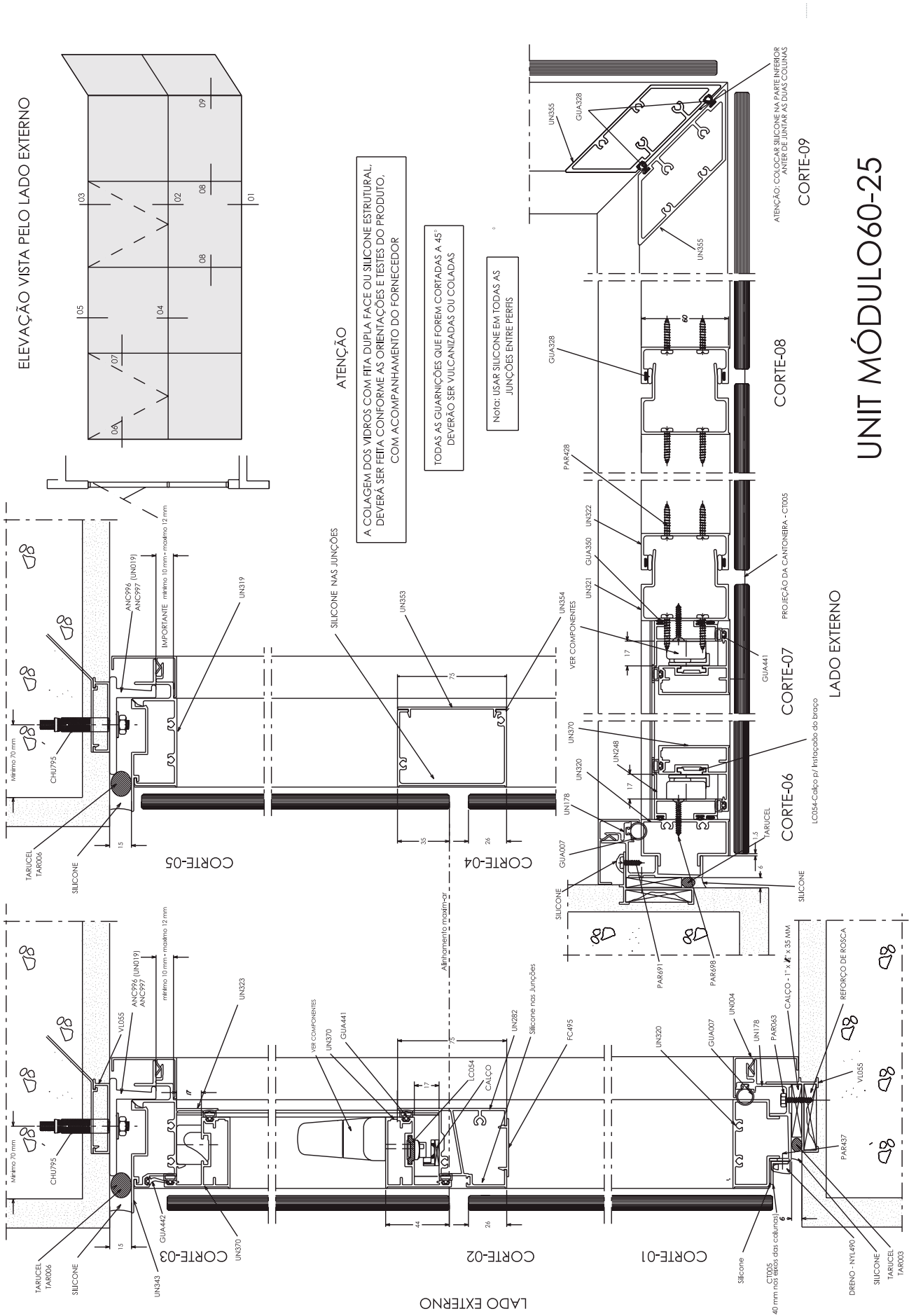
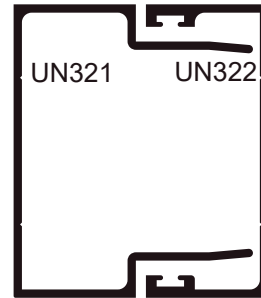
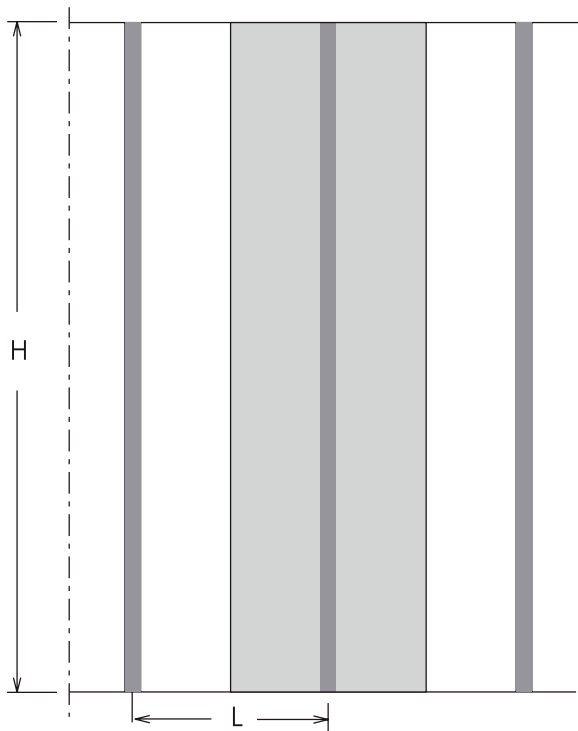

$\text{Área} = 508 \text{ mm}^2$
 $J_x = 278077 \text{ mm}^4$
 $W_x = 9269 \text{ mm}^3$
 $H = 60 \text{ mm}$

Liga 6060 T5

Tensão adm = 7 Kg/mm^2
 Flecha adm = $H/175$ ou 30 mm

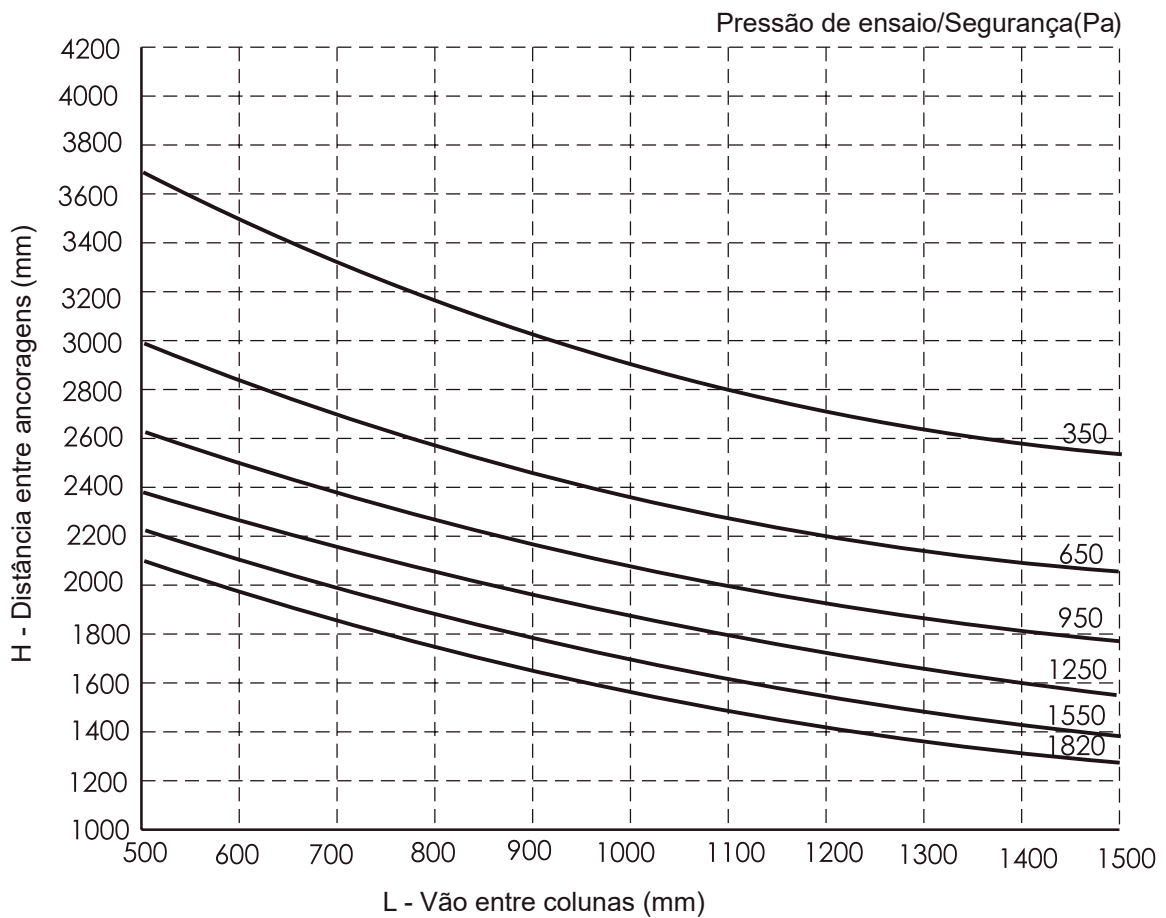

Perfis 60-25

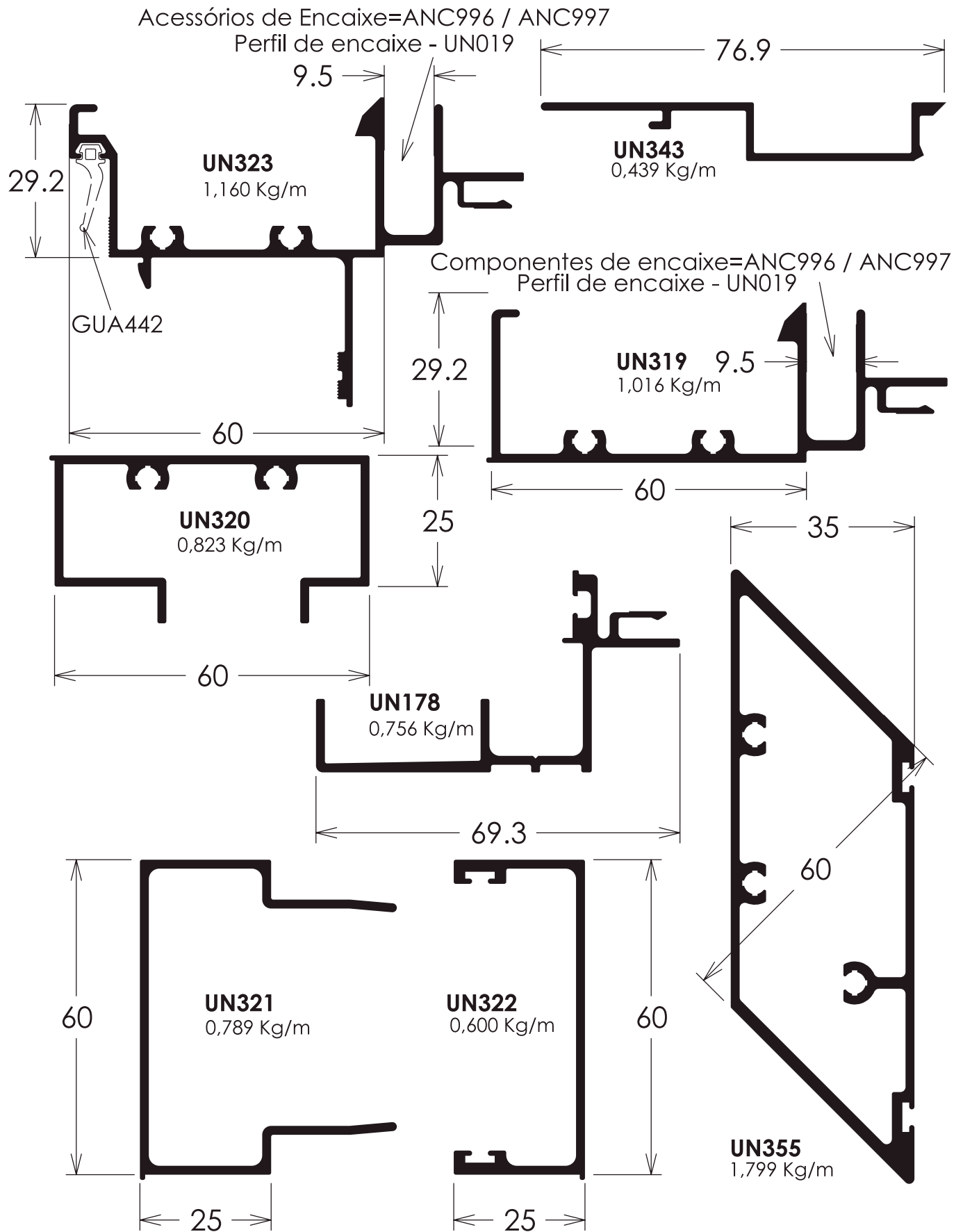

Projetos, perfis, componentes, códigos e sistemas estão sujeitos a alteração sem prévio aviso.

Módulo 80-25

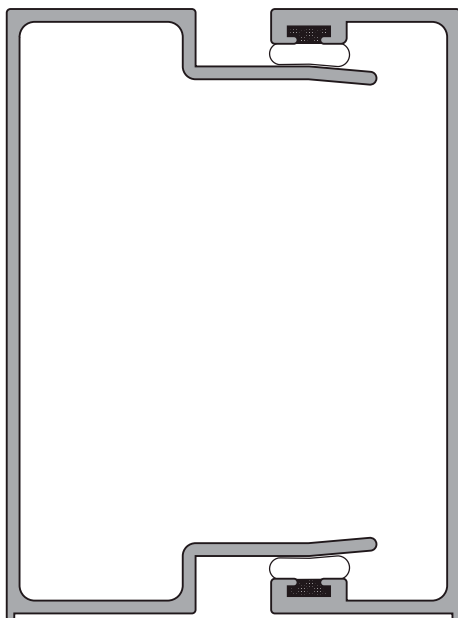

Montagem 80-25

ELEVAÇÃO VISTA PELO LADO EXTERNO

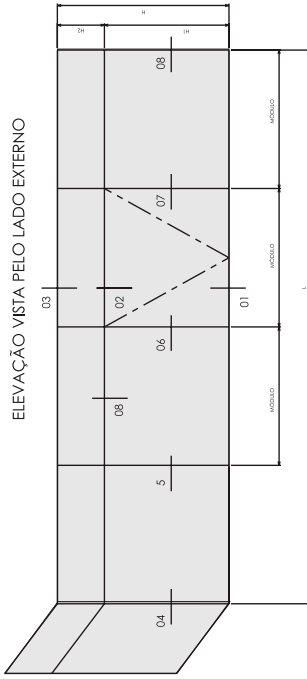

ATENÇÃO

A COLAGEM DOS VIDROS COM FITA DUPLA FACE OU SILICONE ESTRUTURAL DEVERÁ SER FEITA CONFORME AS ORIENTAÇÕES E TESTES DO PRODUTO, COM ACOMPANHAMENTO DO FORNECEDOR.

TODAS AS GUARNIÇÕES QUE FOREM COBERTAS A 45° DEVERÃO SER VULGANIZADAS OU COLADAS.

Nota: USAR SILICONE EM TODAS AS JUNÇÕES ENTRE PERIF.

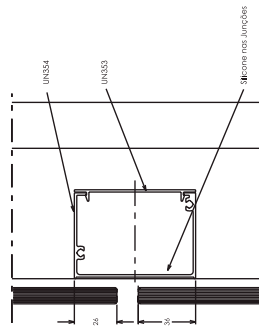

CORTE-08

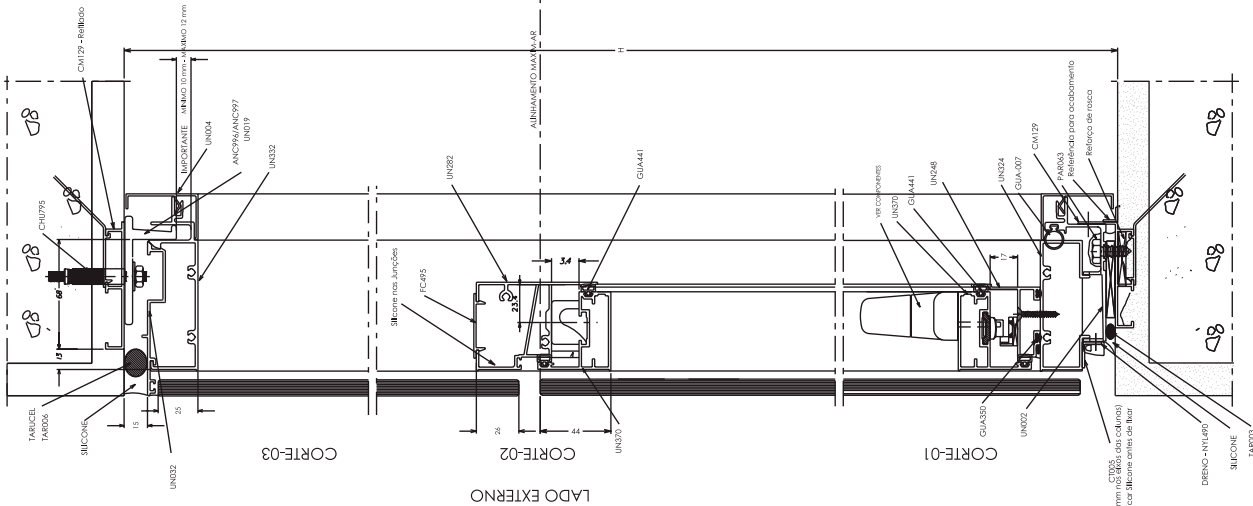

CORTE-03

LADO EXTERNO

CORTE-02

CORTE-01

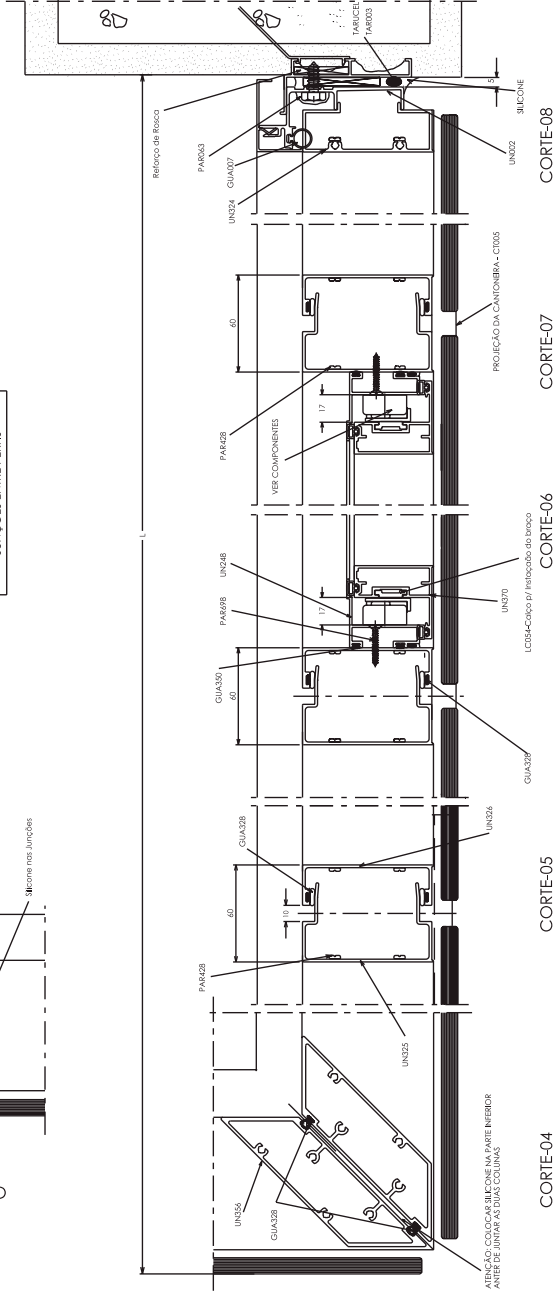

CORTE-04

CORTE-05

CORTE-06

CORTE-07

CORTE-08

LADO EXTERNO
UNIT MÓDULO 80-25
MAXIM-AR C/ FECHO PERIMETRAL

Diagrama de Dimensões

UNIT - Módulo 80 / 25

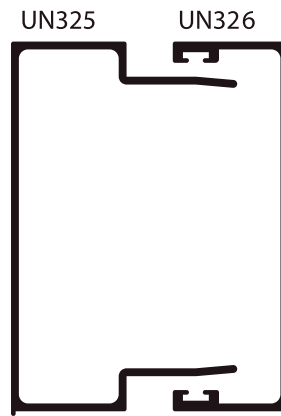
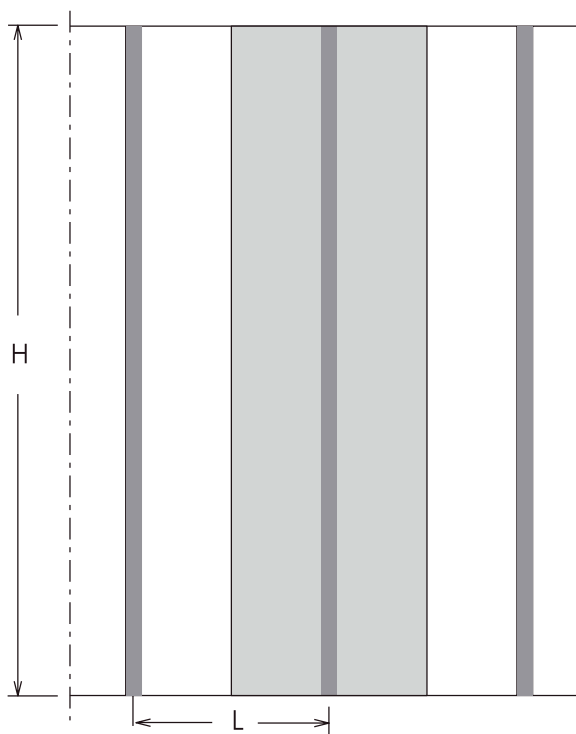

Área = 579 mm²
 Jx = 557121 mm⁴
 Wx = 13645 mm³
 H = 81,7 mm

Liga 6060 T5
 Tensão adm = 7 kg/mm²
 Flecha adm = H/175 ou 30 mm

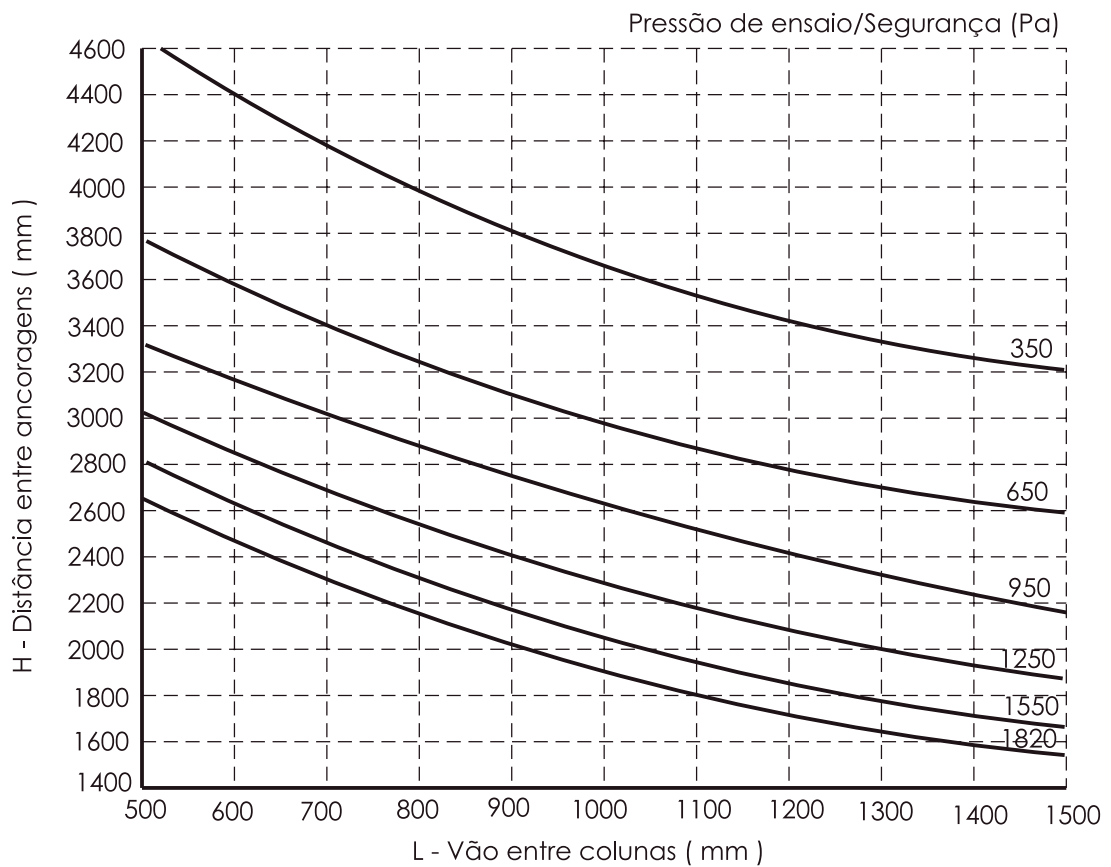

Perfis 80-25

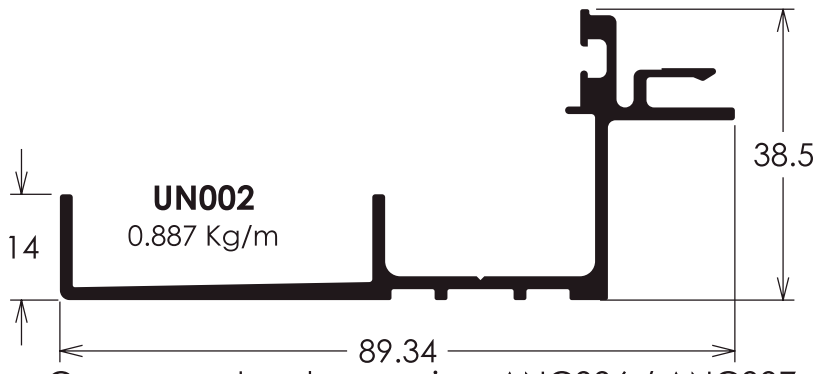
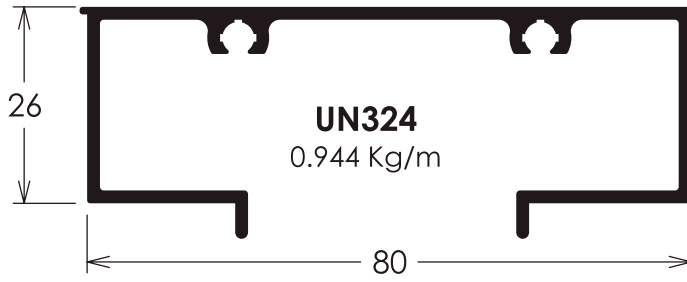

Componentes de encaixe=ANC996 / ANC997
Perfil de encaixe-UN019

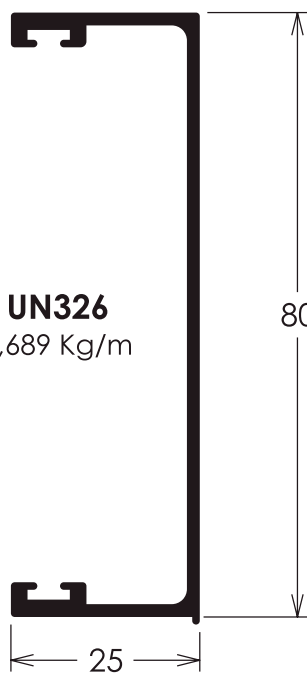
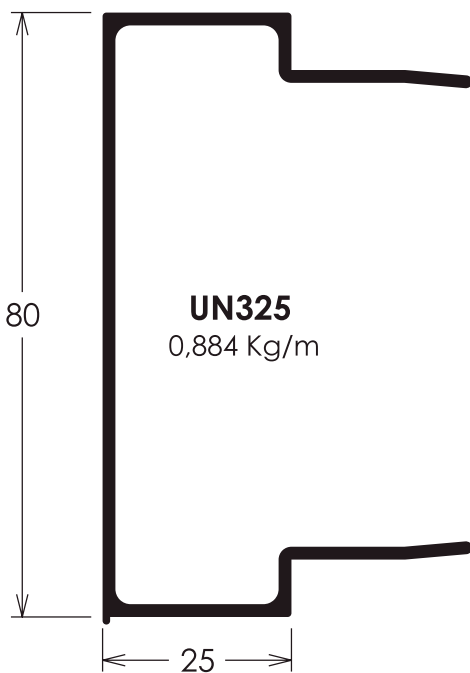
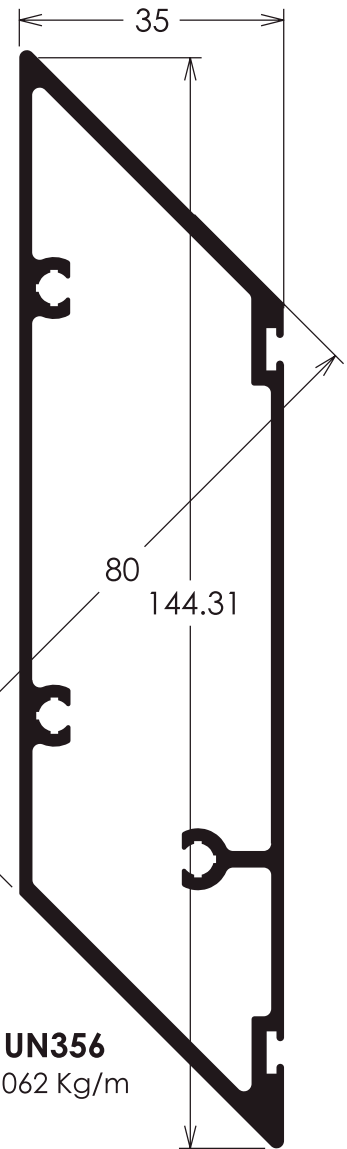

Projetos, perfis, componentes, códigos e sistemas estão sujeitos a alteração sem prévio aviso.

Módulo 80-35 Rebaixo

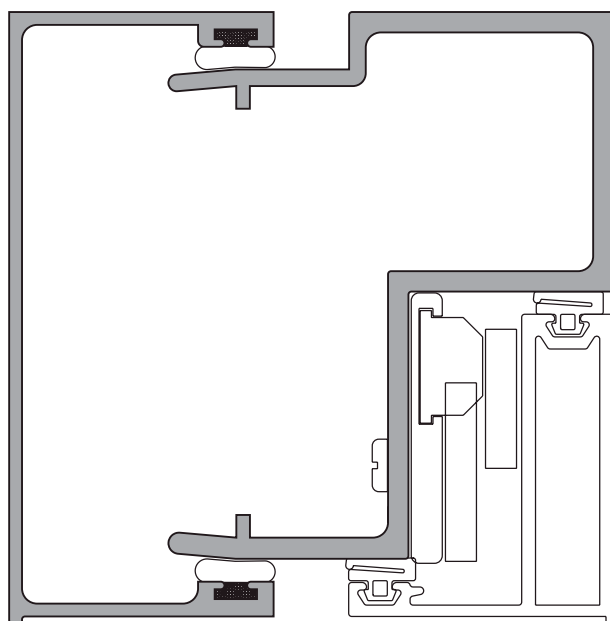

Montagem 80-35 Rebaixo

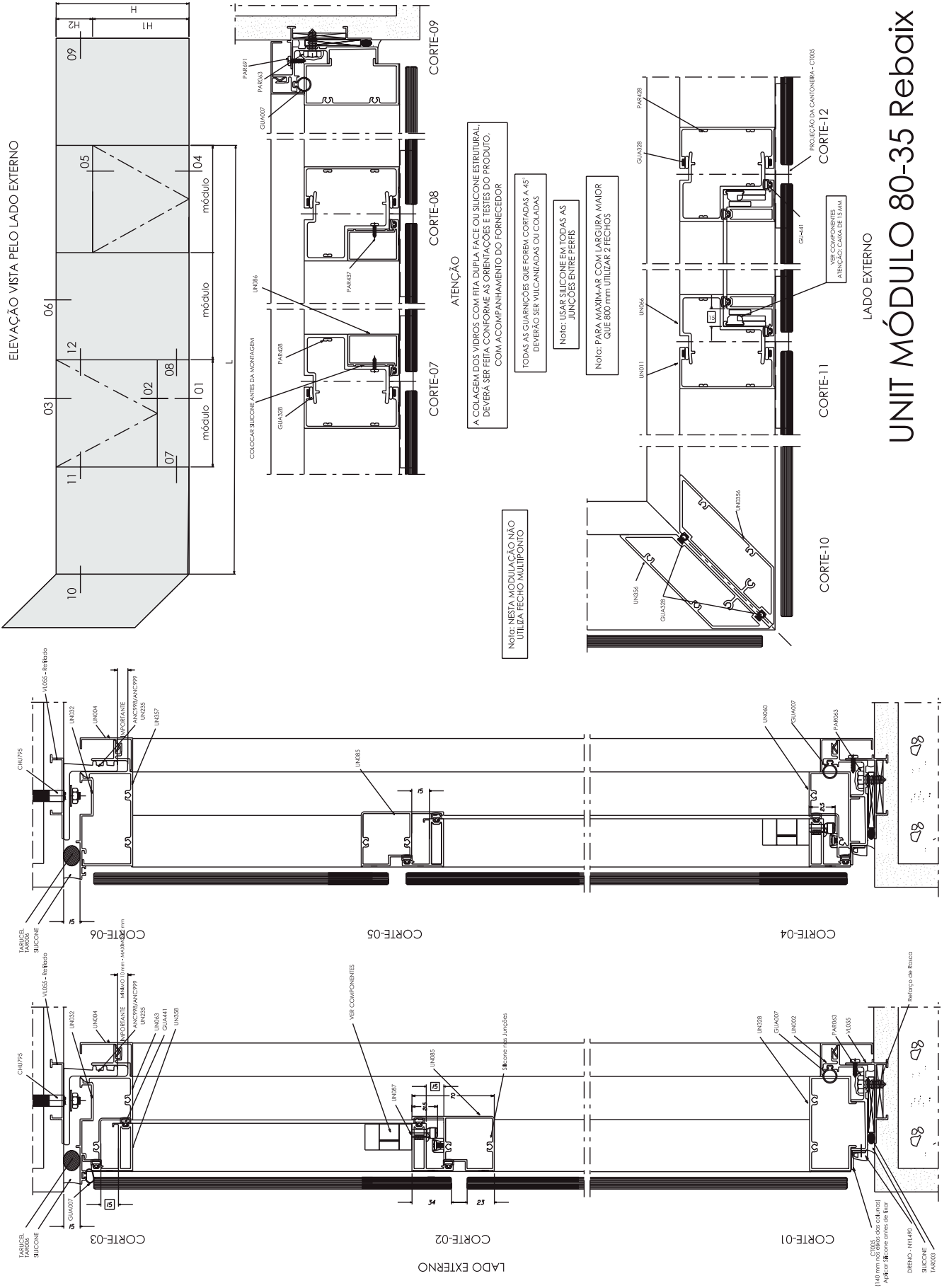

UNIT MÓDULO 80-35 Rebaixo

Diagrama de Dimensões

UNIT - Módulo 80 / 35 Rebaixo

Liga 6060 T5

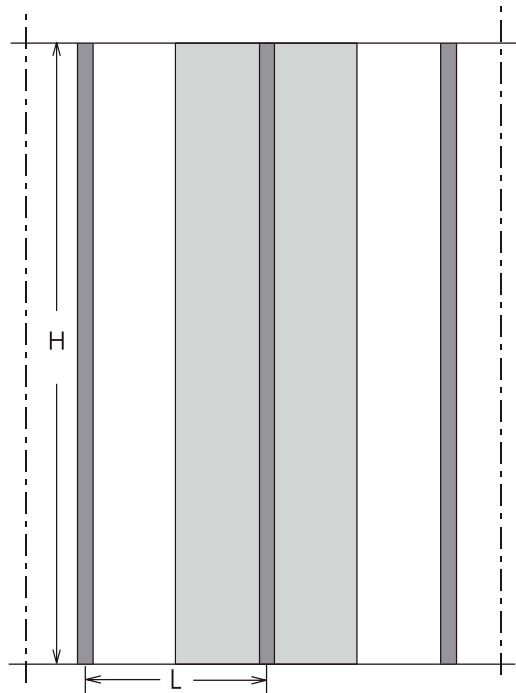

UN011

UN066

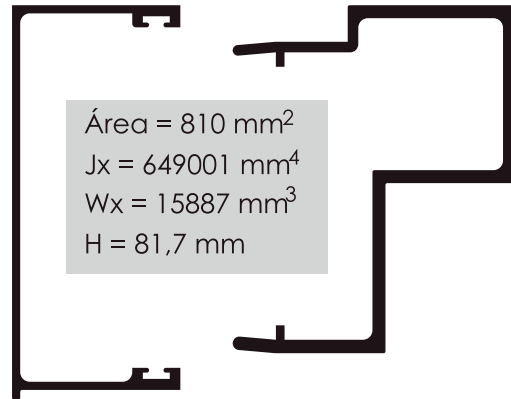

Tensão adm = 7 kg/mm²

Flecha adm = H/175 ou 30 mm

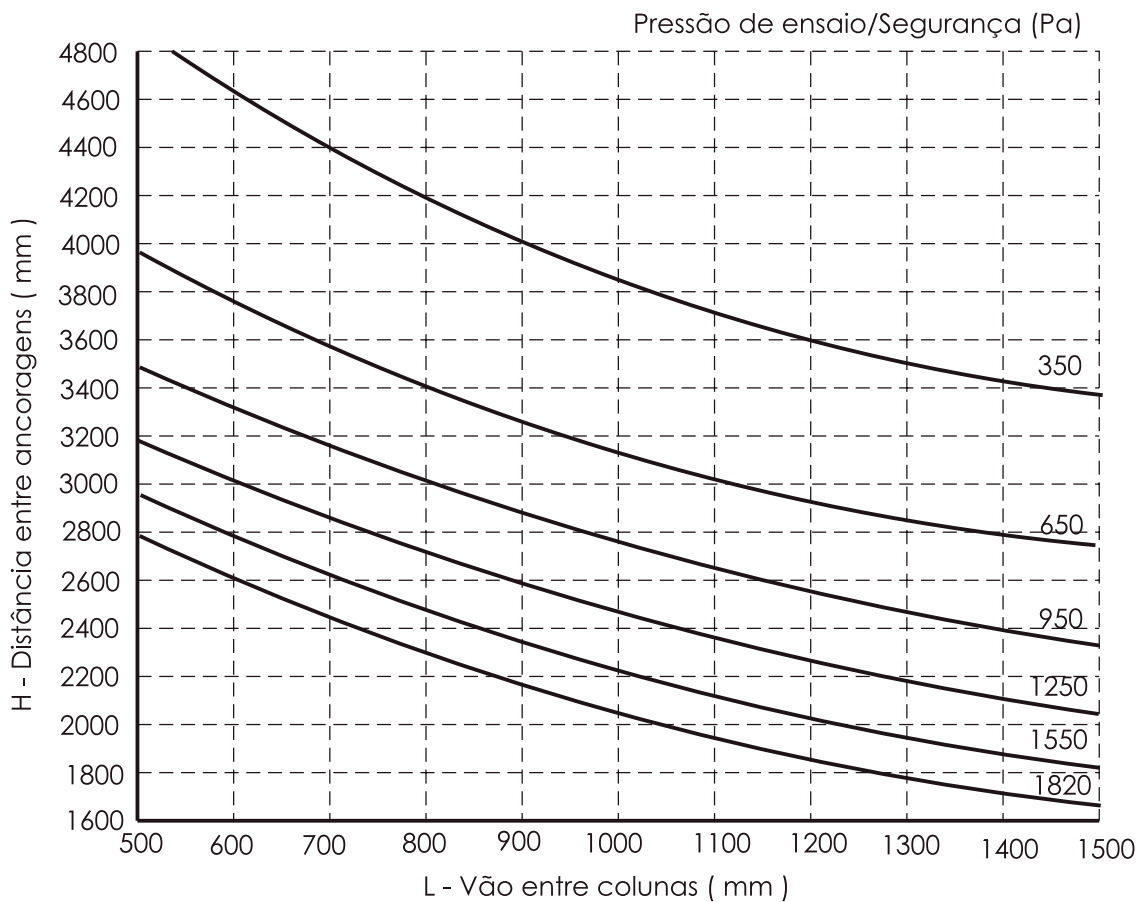

Perfis 80-35 Rebaixo

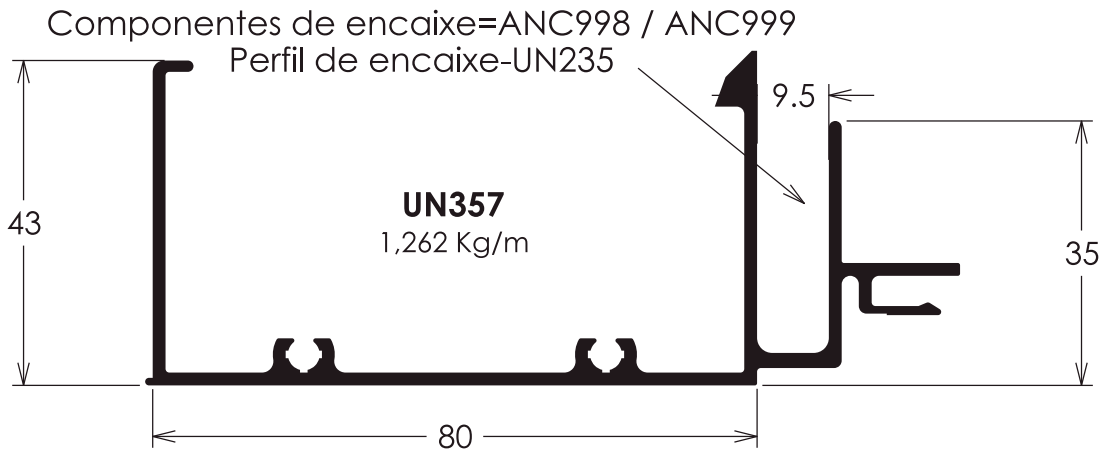
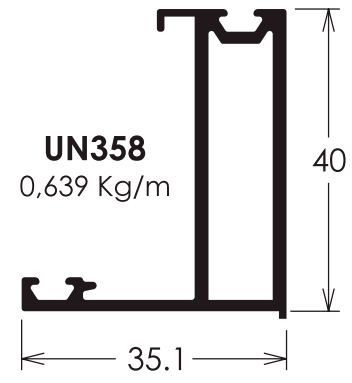
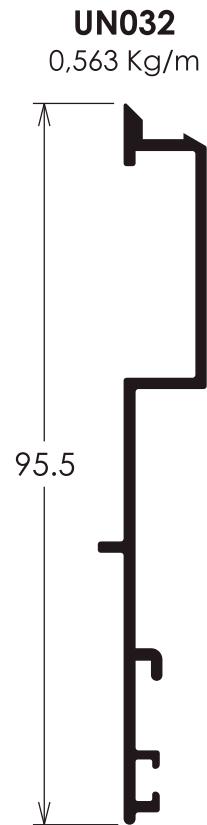
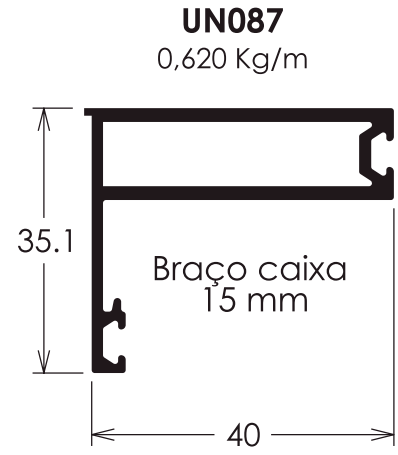
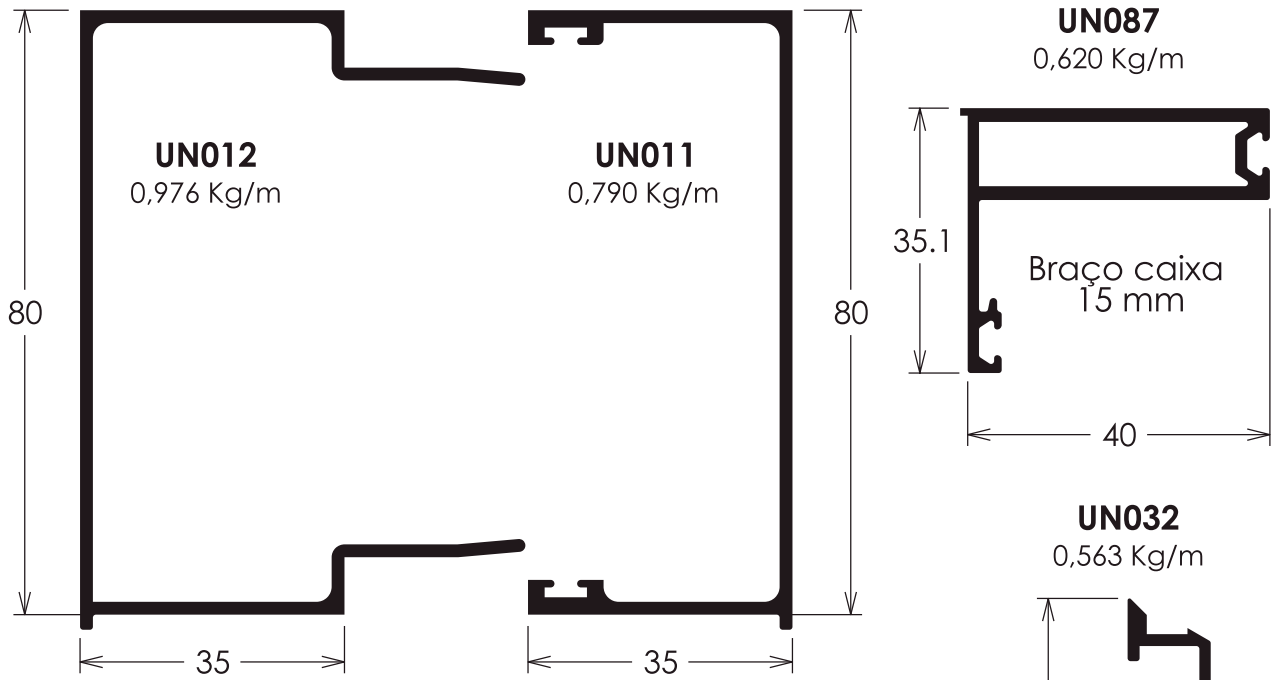

Projetos, perfis, componentes, códigos e sistemas estão sujeitos a alteração sem prévio aviso.

Perfis 80-35 Rebaixo

UN328
1,033 Kg/m

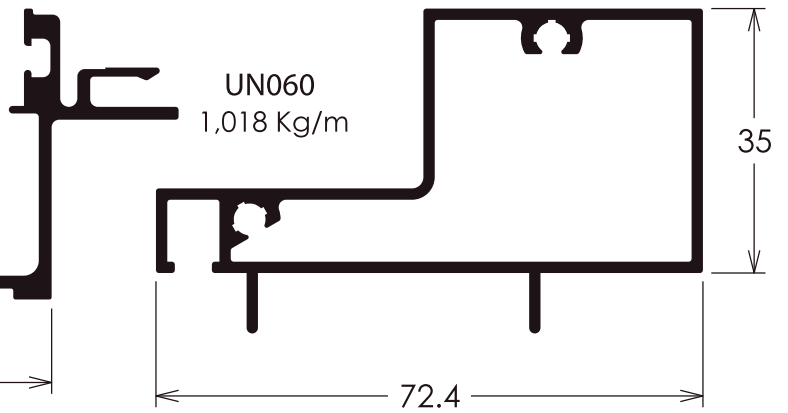
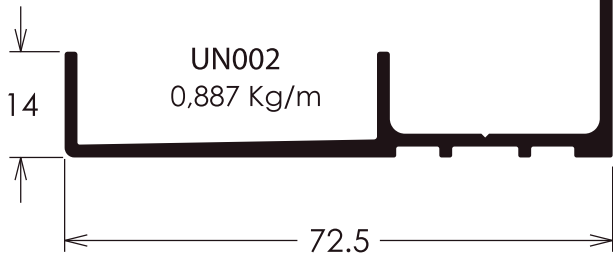
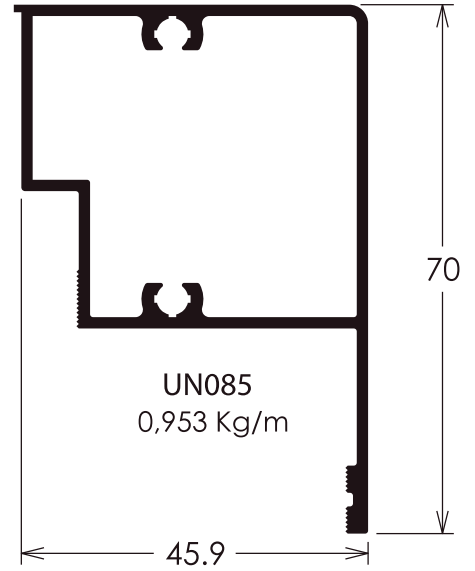
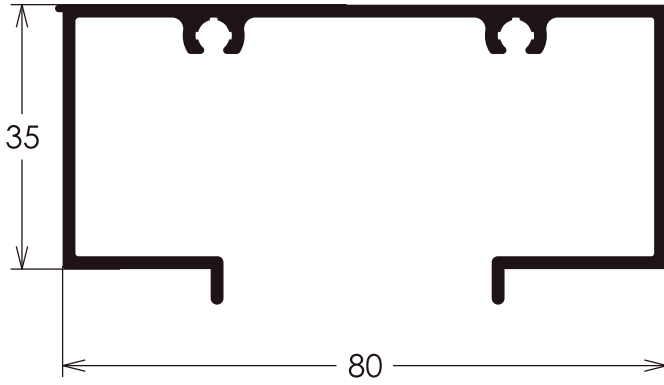

Projetos, perfis, componentes, códigos e sistemas estão sujeitos a alteração sem prévio aviso.

Módulo 80-35



Diagrama de Dimensões

UNIT - Módulo 80 / 35

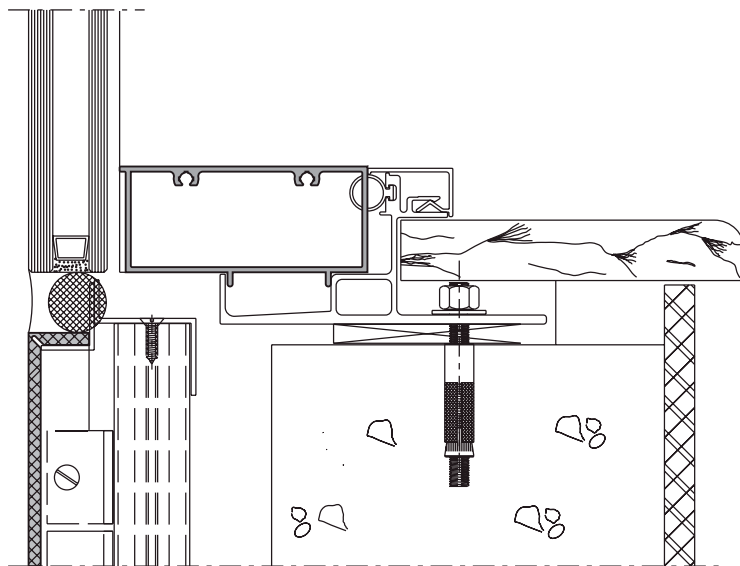
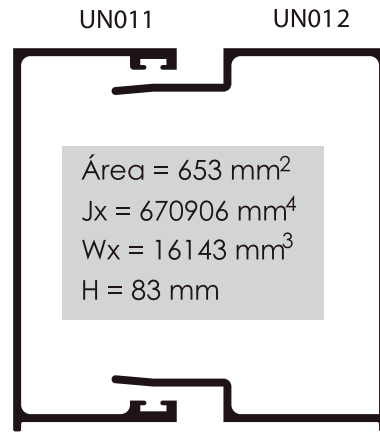
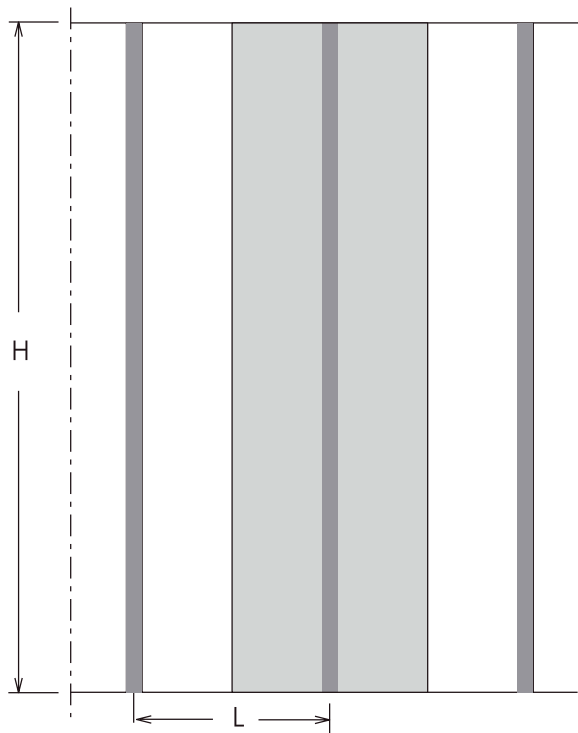

Liga 6060 T5

Tensão adm = 7 kg/mm²

Flecha adm = H/175 ou 30 mm

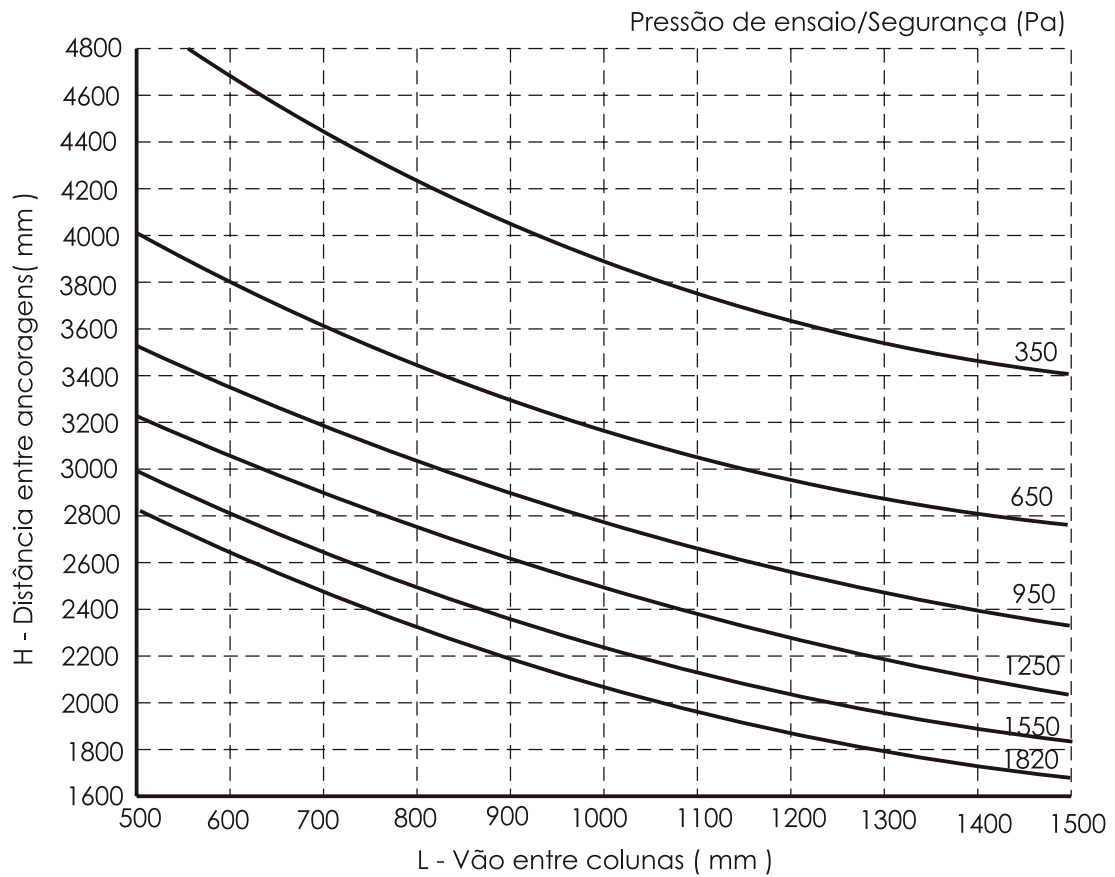

Perfis 80-35

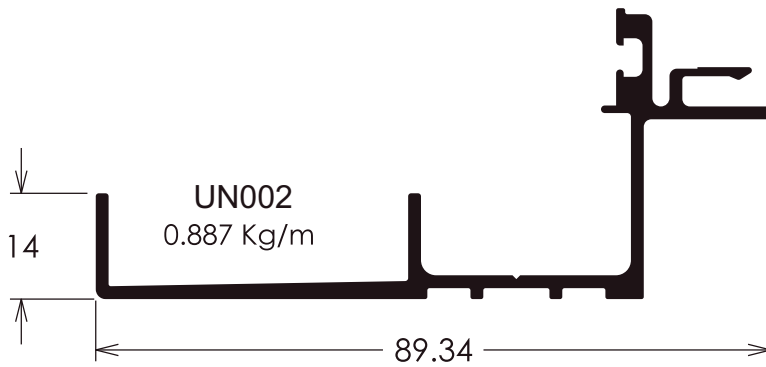
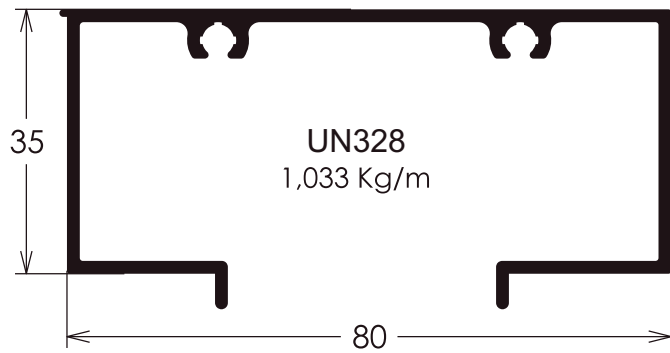

Componentes de encaixe=ANC996 / ANC997

Perfil de encaixe-UN019

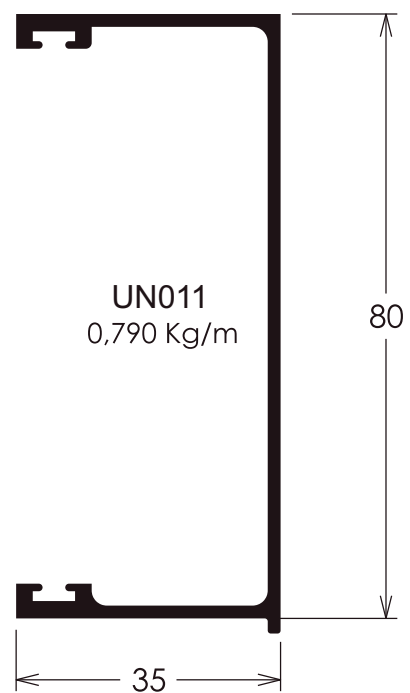
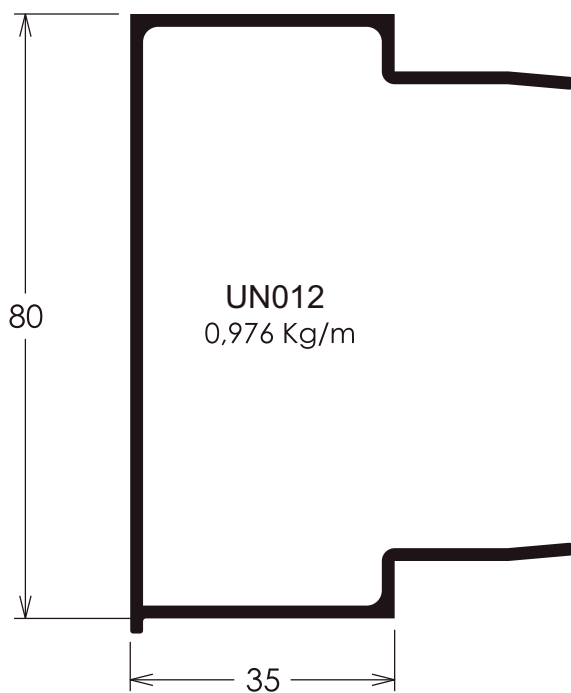
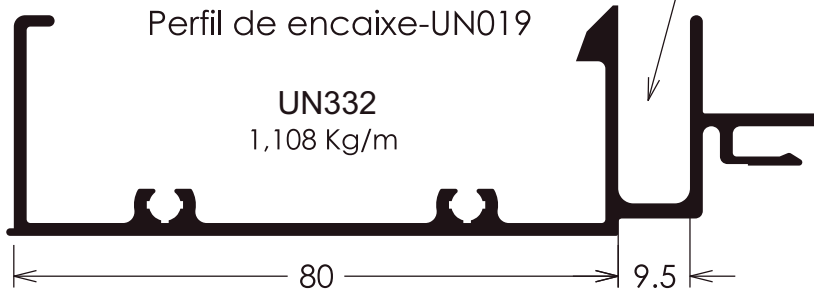

Perfis 80-35

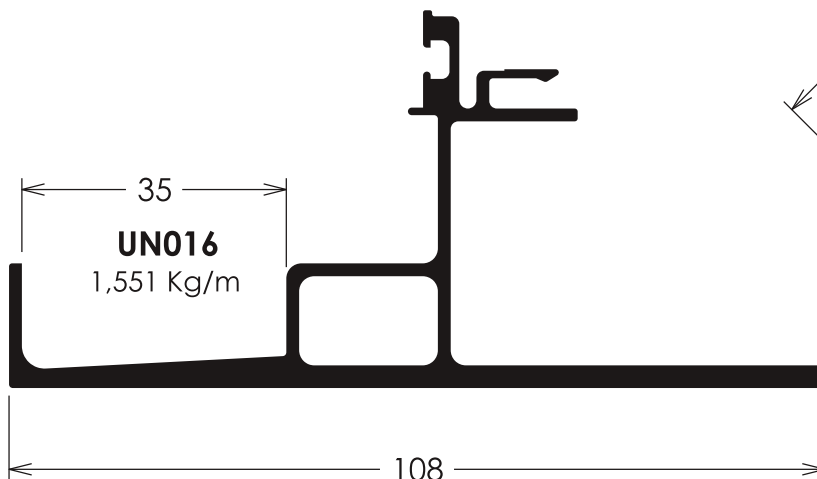
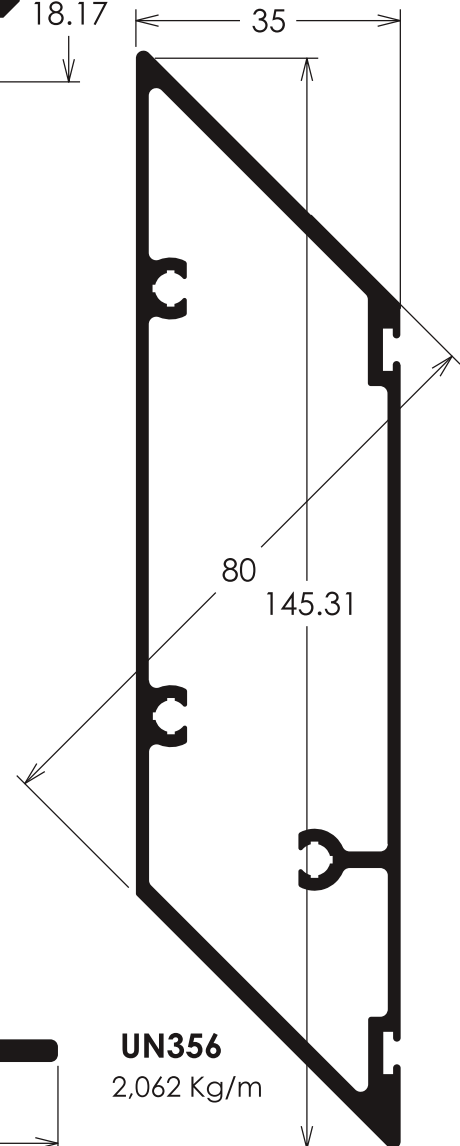
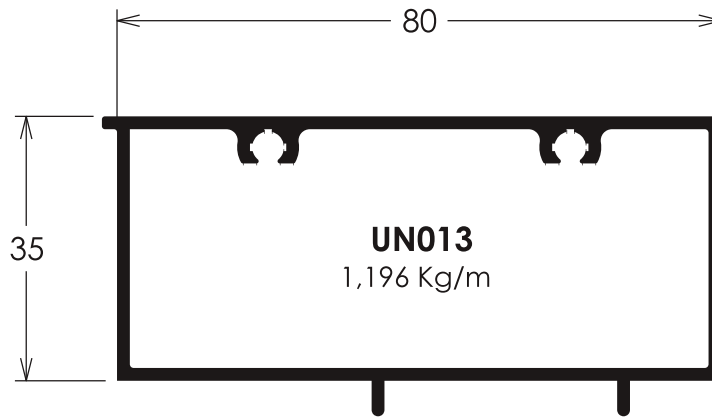

Projetos, perfis, componentes, códigos e sistemas estão sujeitos a alteração sem prévio aviso.

Módulo 80-35R

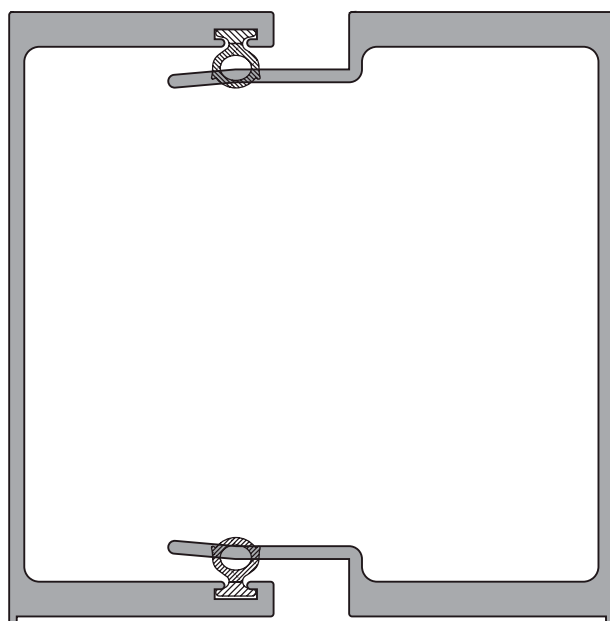

Montagem 80-35R

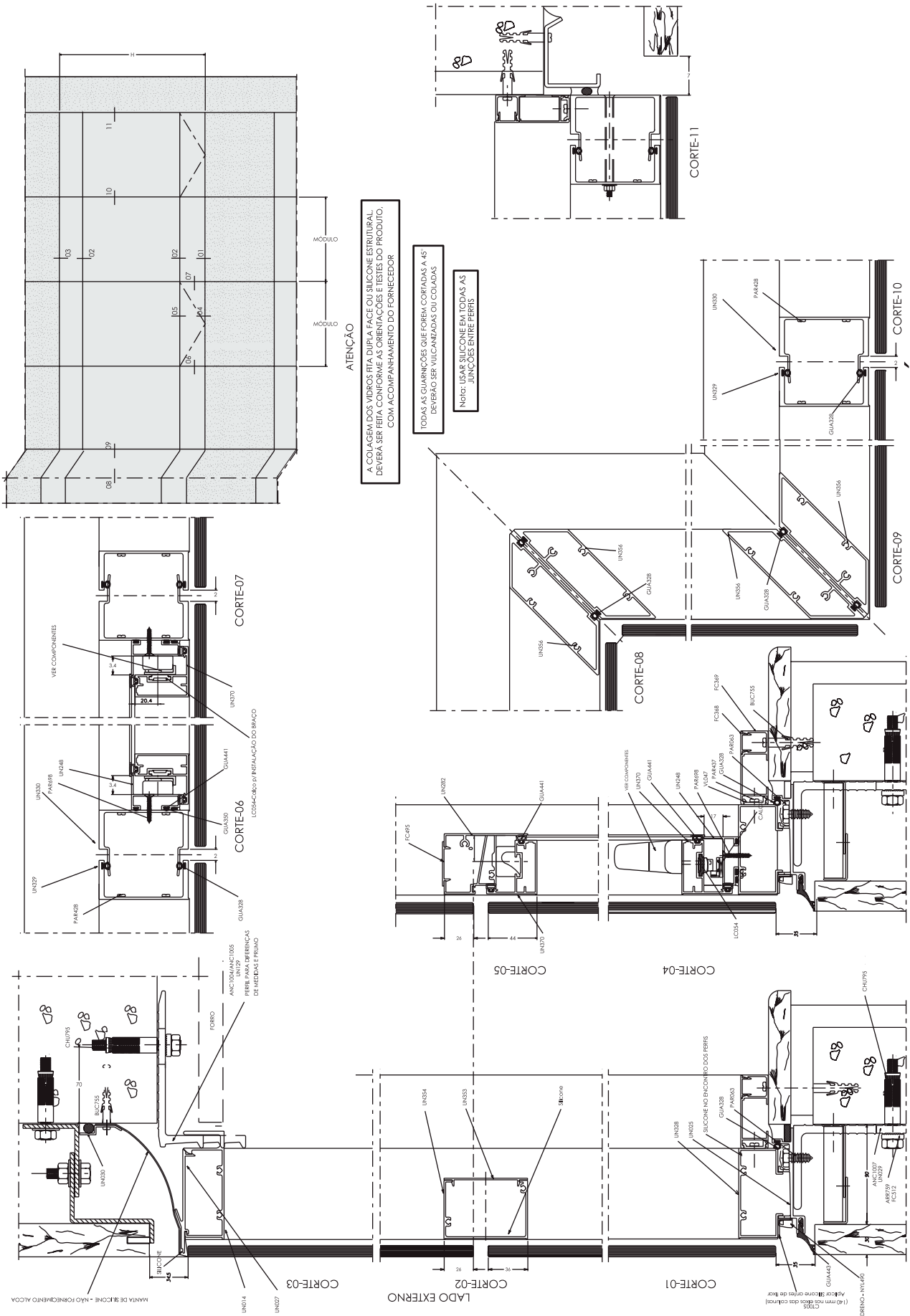

UNIT MÓDULO 80-35R MAXIM-AR COM FECHO PERIMETRAL

Montagem 80-35R

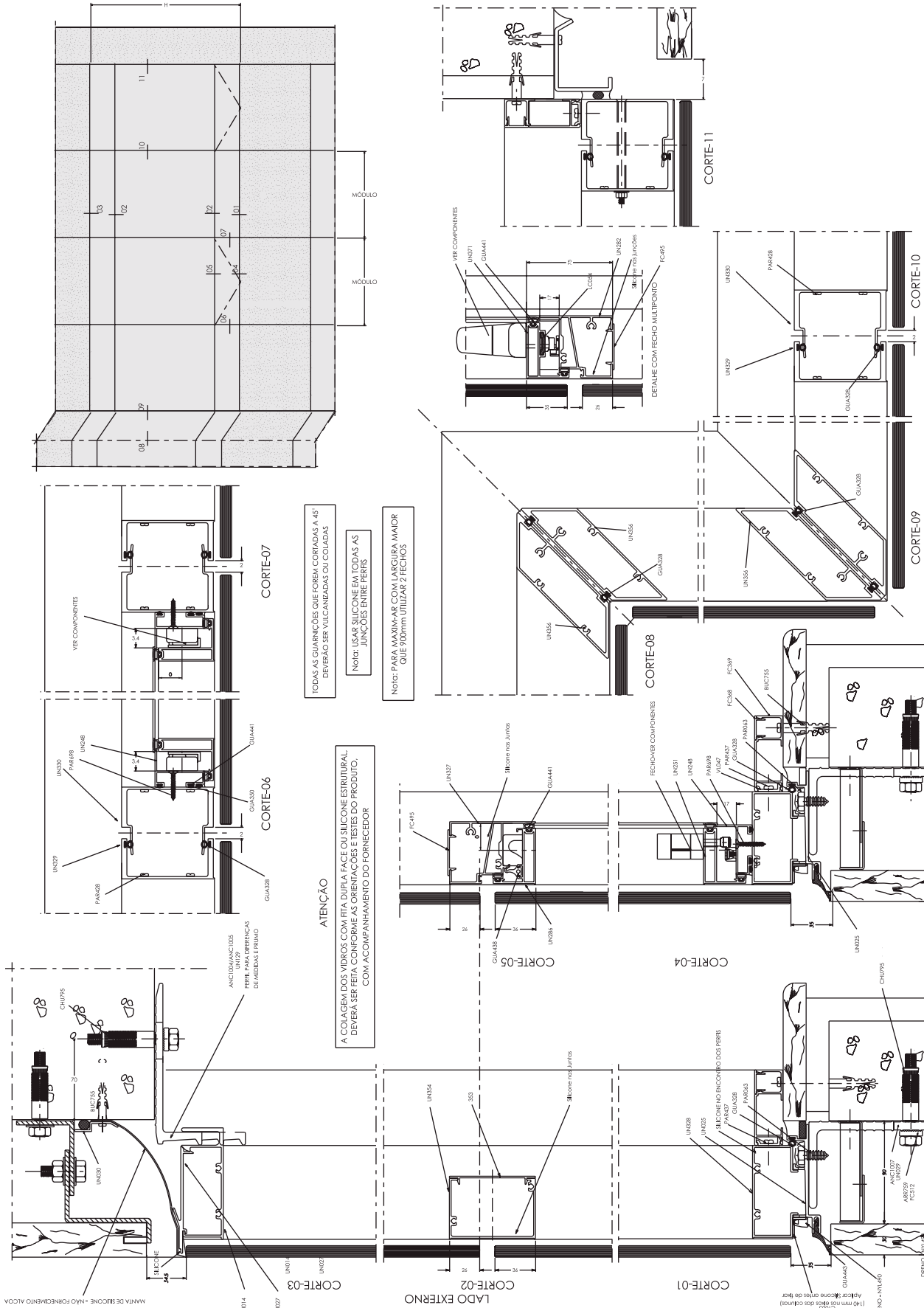

NOTA: USAR SILICONE EM TODAS AS JUNÇÕES ENTRE PERFILS PARA MÁXIMA-AR COM LARGURA MAIOR QUE 900mm UTILIZAR 2 FECHOS

ATENÇÃO
A COLAGEM DOS VIDROS COM FITA DUPLA FACE OU SILICONE ESTRUTURAL, DEVERÁ SER FEITA CONFORME AS ORIENTAÇÕES E TESTES DO PRODUTO, COM ACOMPANHAMENTO DO FORNECEDOR

NOTA: USAR SILICONE EM TODAS AS JUNÇÕES ENTRE PERFILS

TODAS AS GUARNIÇÕES QUE FOREM FORNIDAS A 45° DEVERÃO SER VULCANIZADAS OU COLADAS

MAXIM-AR C/ FECHO SIMPLES E FECHO MULTIPONTO

Montagem 80-35R

UNIT MÓDULO 80-35R LADO EXTERNO MAXIM-AR C/ FECHO PERIMETRAL

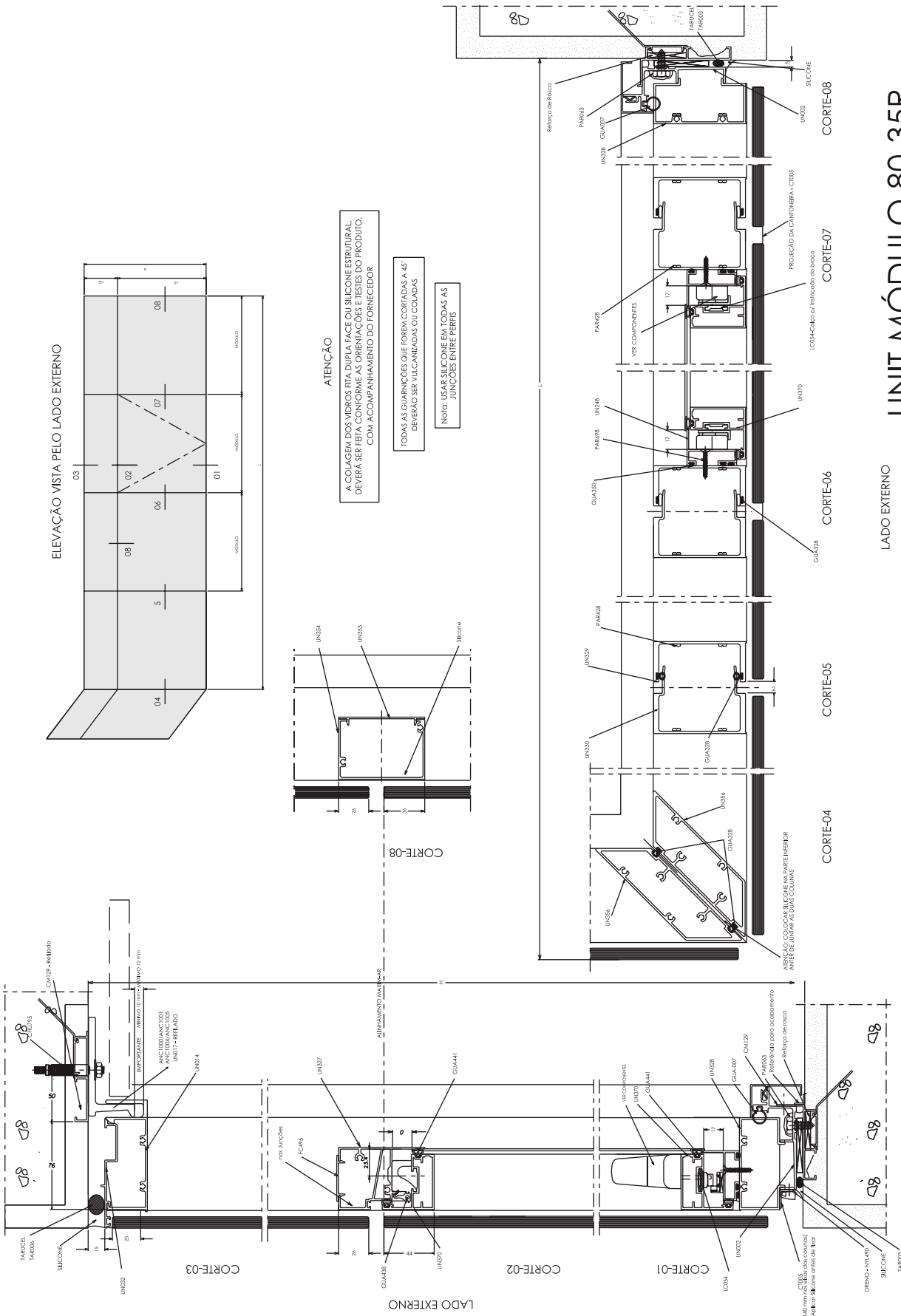

Montagem 80-35R

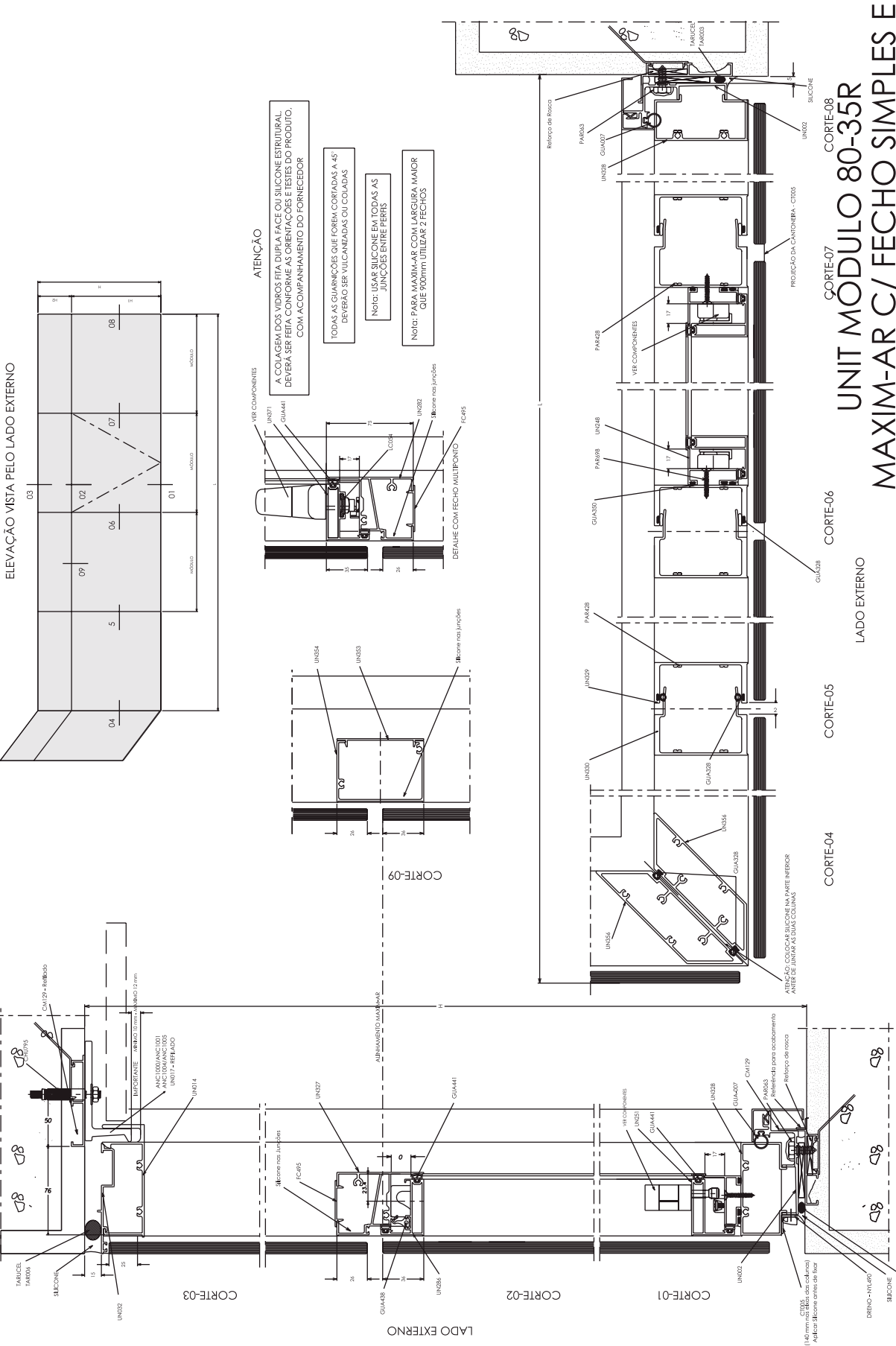

UNIT MODULO 80-35R MAXIM-AR C/ FECHO SIMPLES E FECHO MULTIPONTO

Diagrama de Dimensões

UNIT - Módulo 80 / 35 R

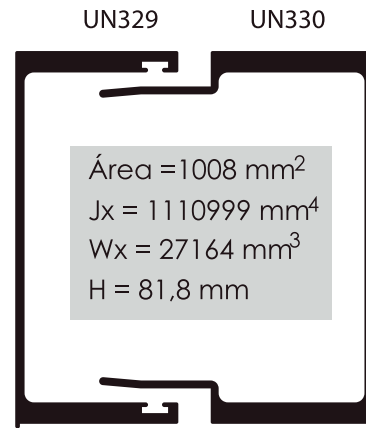
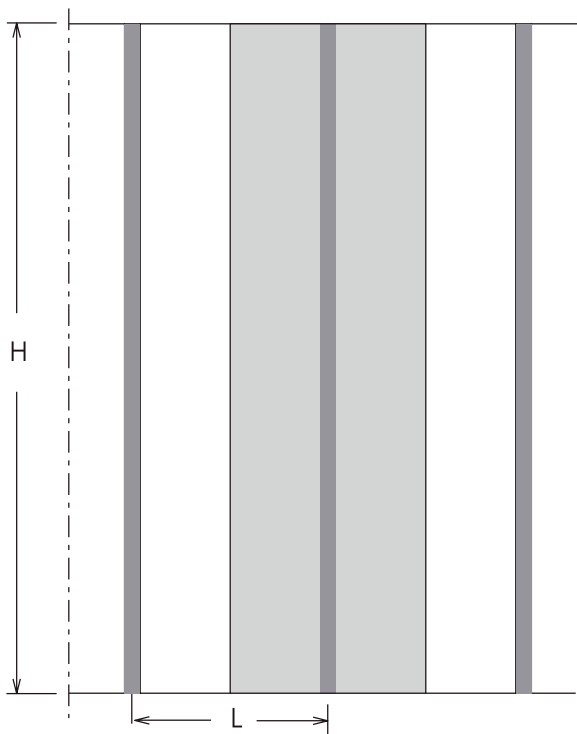

Liga 6060 T5

Tensão adm = 7 kg/mm^2

Flecha adm = $H/175$ ou 30 mm

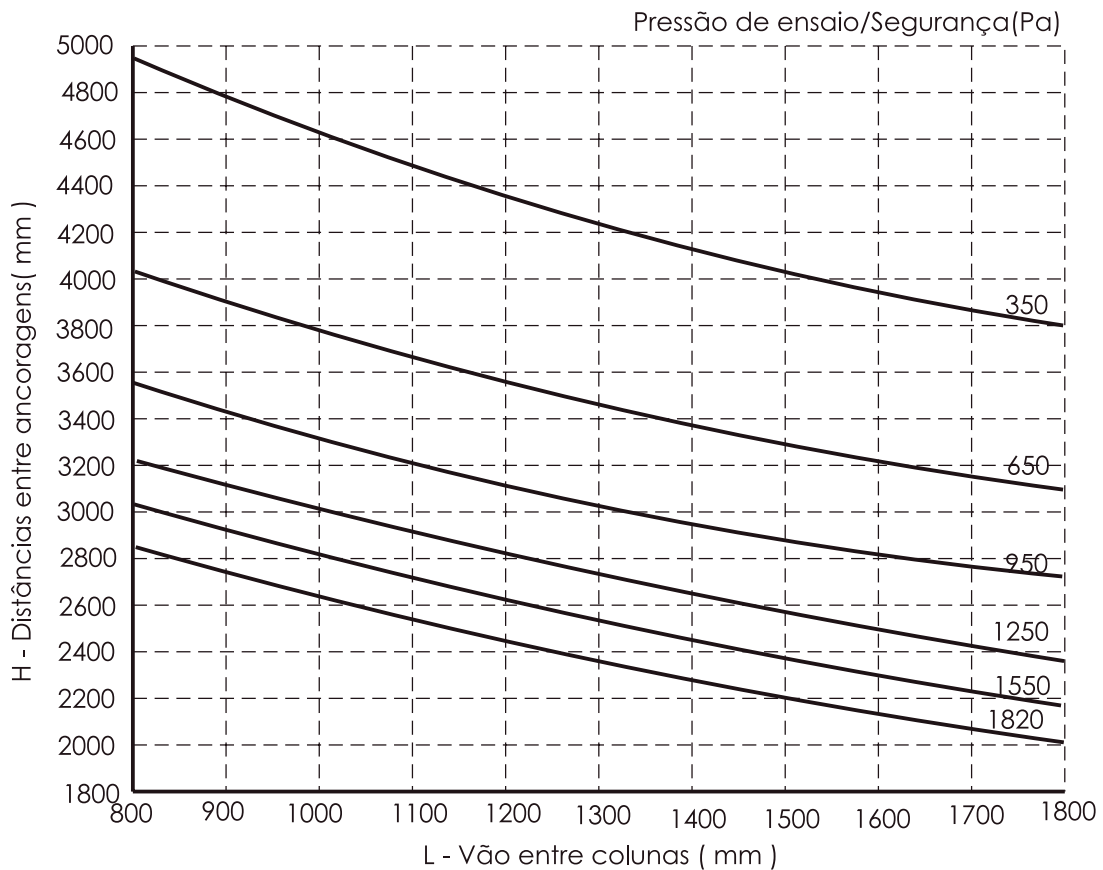

Perfis 80-35R

Componentes de encaixe=ANC1000 / ANC1001
 ANC1004 E ANC1005
 Perfis de encaixe - UN017 e UNT129

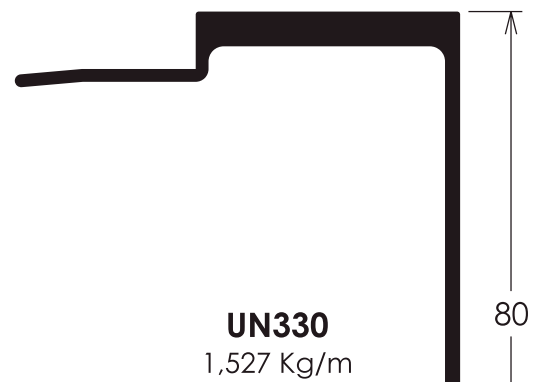
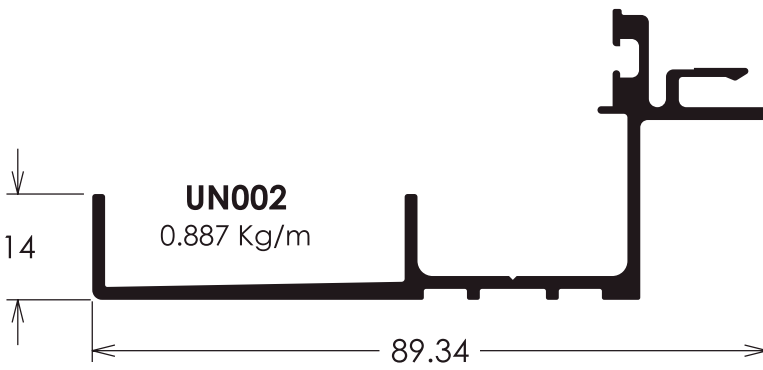
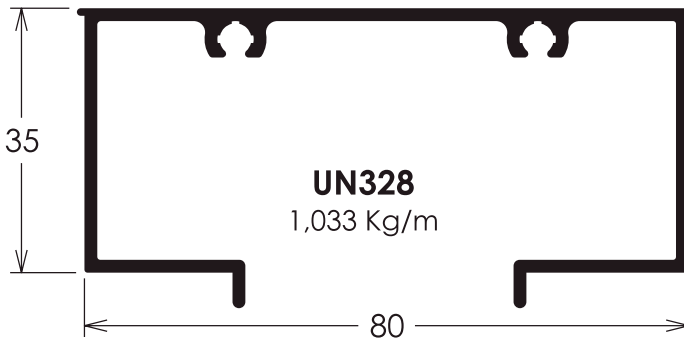
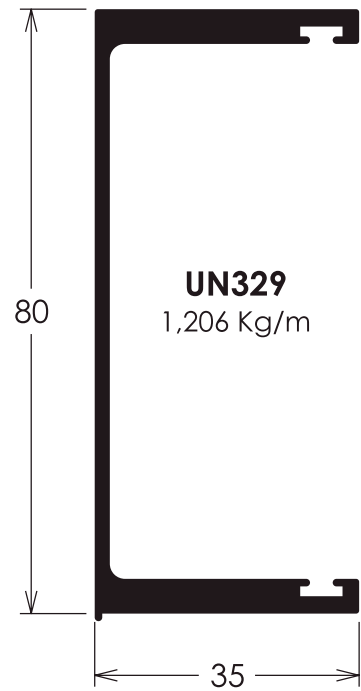
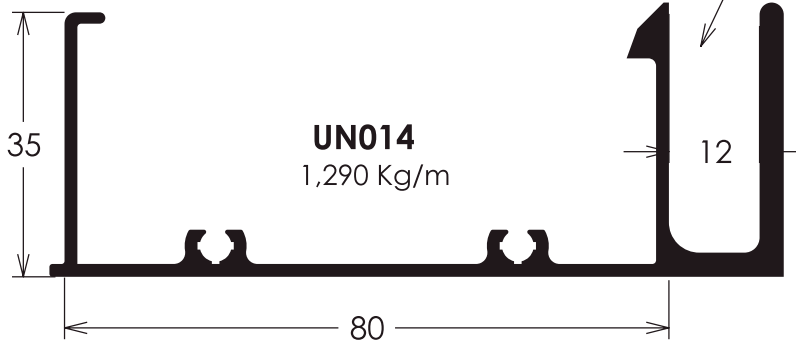

Componentes de encaixe=ANC996 / ANC997
 Perfil de encaixe - UN019

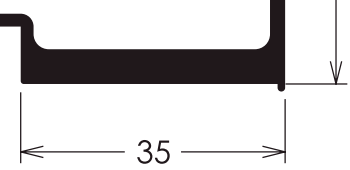
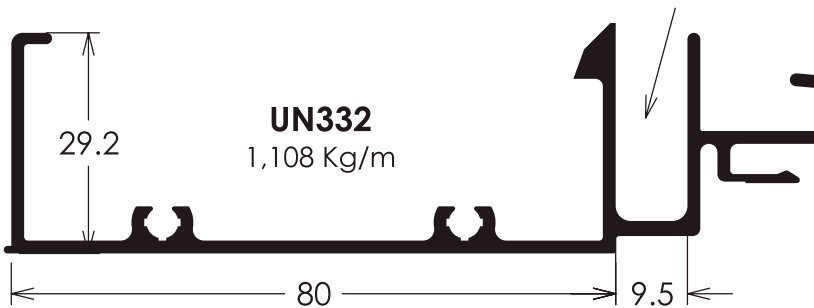

Projetos, perfis, componentes, códigos e sistemas estão sujeitos a alteração sem prévio aviso.

Perfis 80-35R

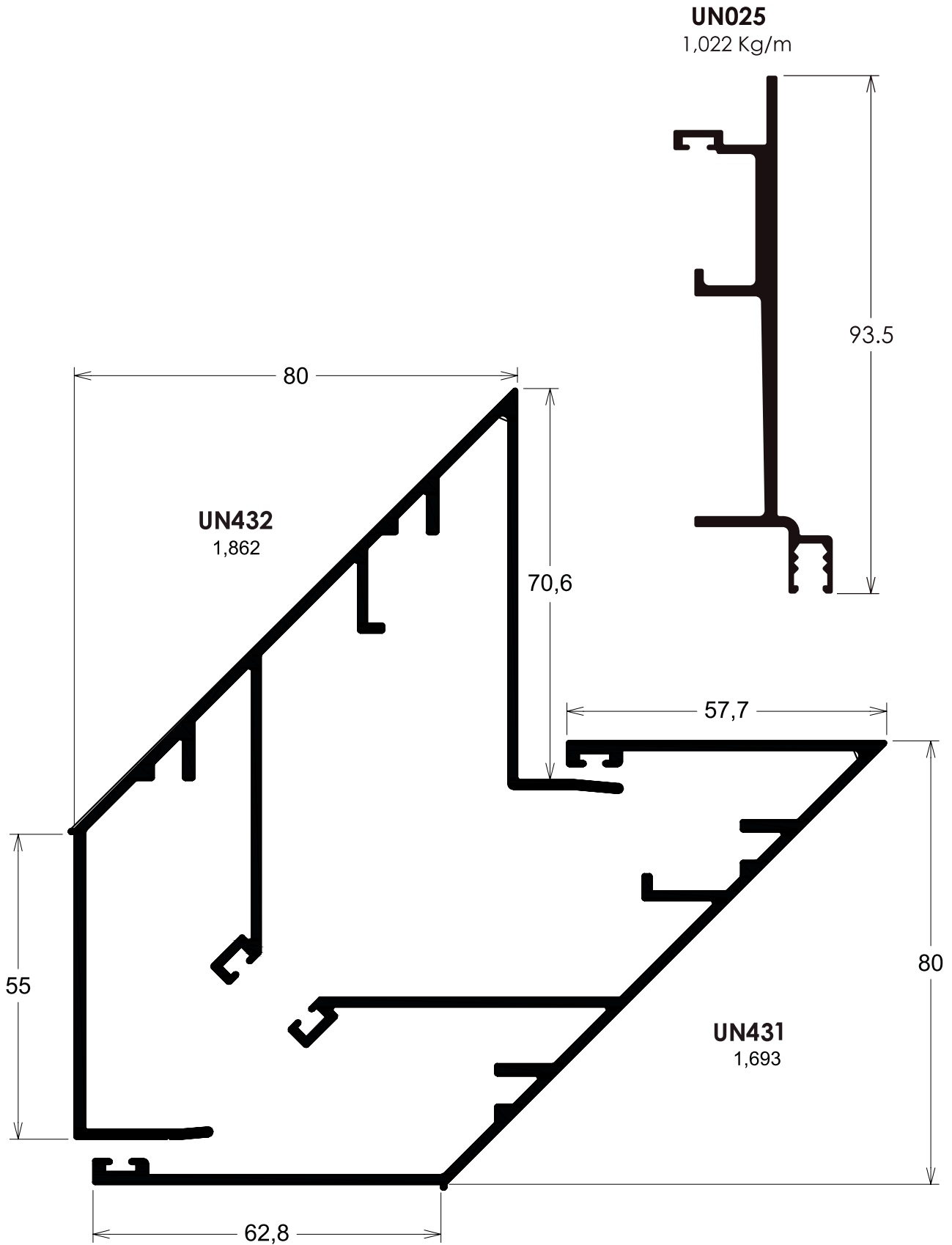

Projetos, perfis, componentes, códigos e sistemas estão sujeitos a alteração sem prévio aviso.

Perfis 80-35R

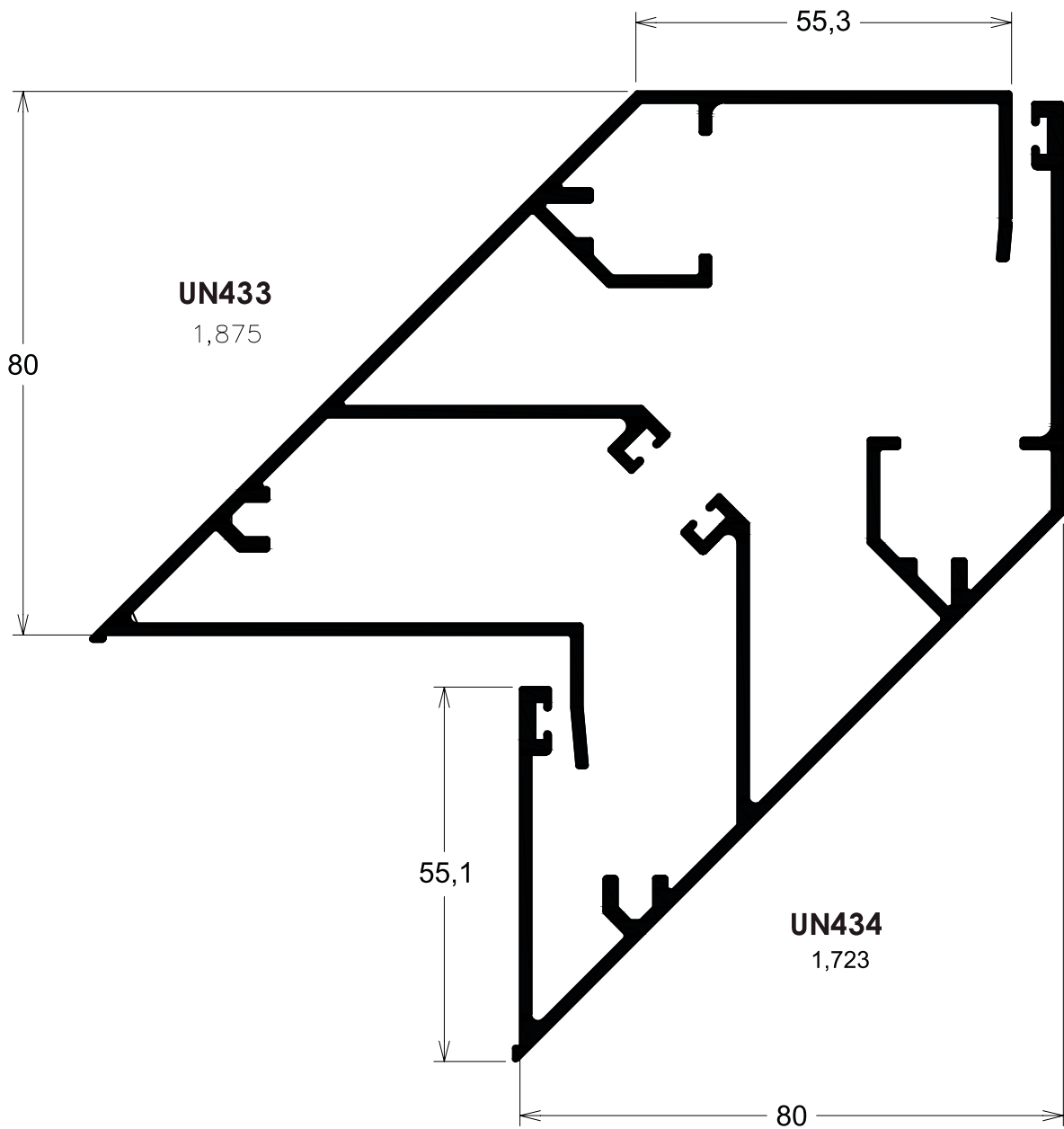

Projetos, perfis, componentes, códigos e sistemas estão sujeitos a alteração sem prévio aviso.

Módulo 100 Encaixilhado

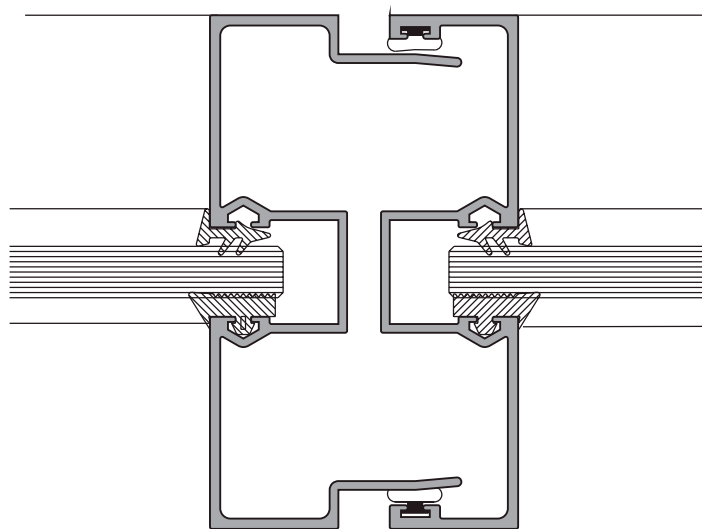

Montagem 100 Encaixilhado

UNIT MÓDULO 100 ENCAIXILHADO

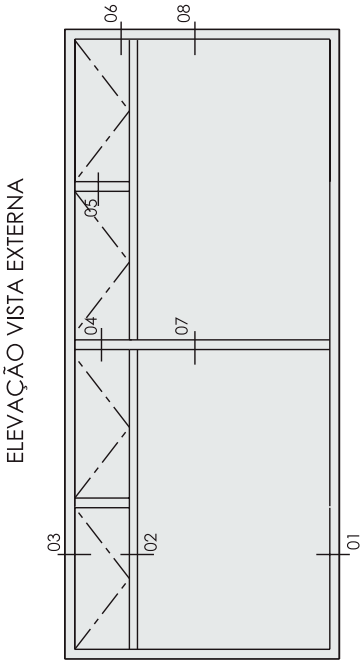

A COLAGEM DOS VIDROS COM FITA DÚPLA FACE OU SILICONE ESTRUTURAL DEVERÁ SER FEITA CONFORME AS ORIENTAÇÕES E TESTES DO PRODUTO, COM ACOMPANHAMENTO DO FORNECEDOR.

TODAS AS GUARNIÇÕES QUE FOREM CORTADAS A 45° DEVERÃO SER VULCANIZADAS OU COLADAS.

Nota: USAR SILICONE EM TODAS AS JUNÇÕES ENTRE PERFIS.

Nota: PARA MAXIMIZAR COM A REQUISA MAIOR QUE 700mm UTILIZAR 2 TECHOS.

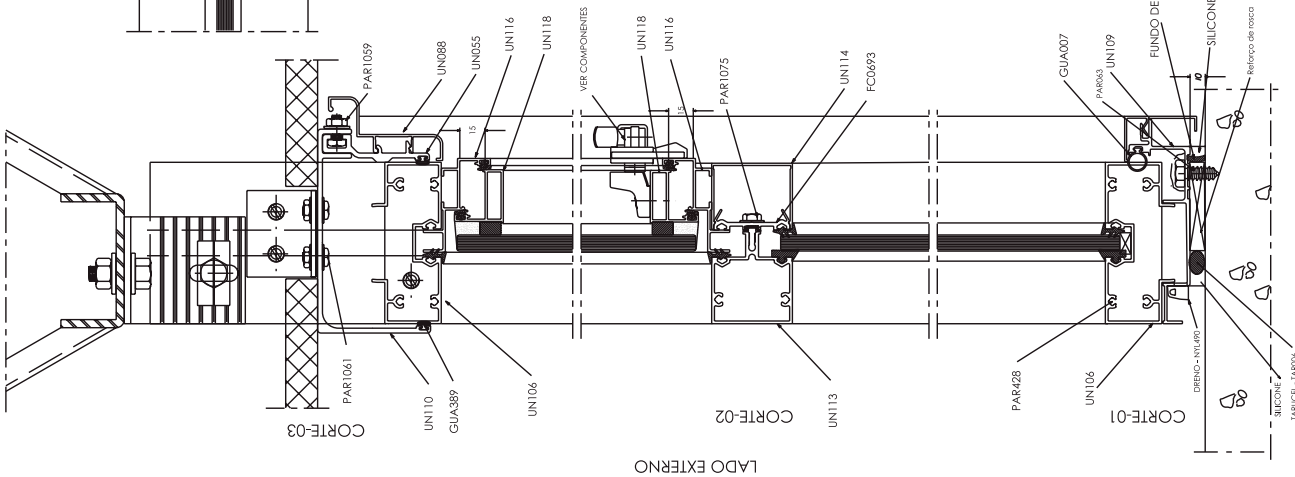
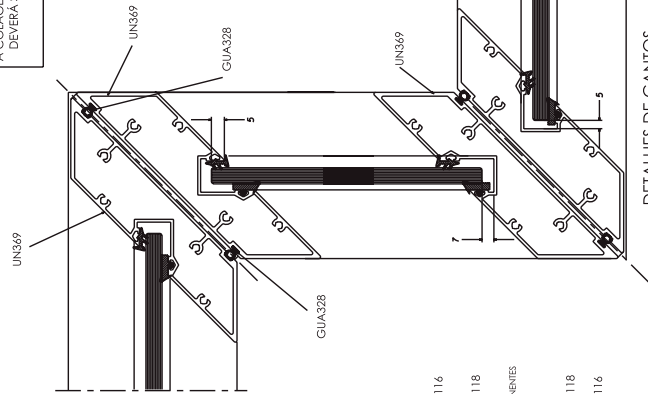

COMPONENTE A SER DESENVOLVIDO PELO FABRICANTE DE ESQUADRIA, CONFORME MEDIDAS DA FACHADA E PRESSÃO DE VENTO.

LADO EXTERNO
LADO EXTERNO

DETALHE PARA TERREO
S/ ESCALA

LADO EXTERNO

Diagrama de Dimensões

UNIT - Módulo 100 - Encaixilhado

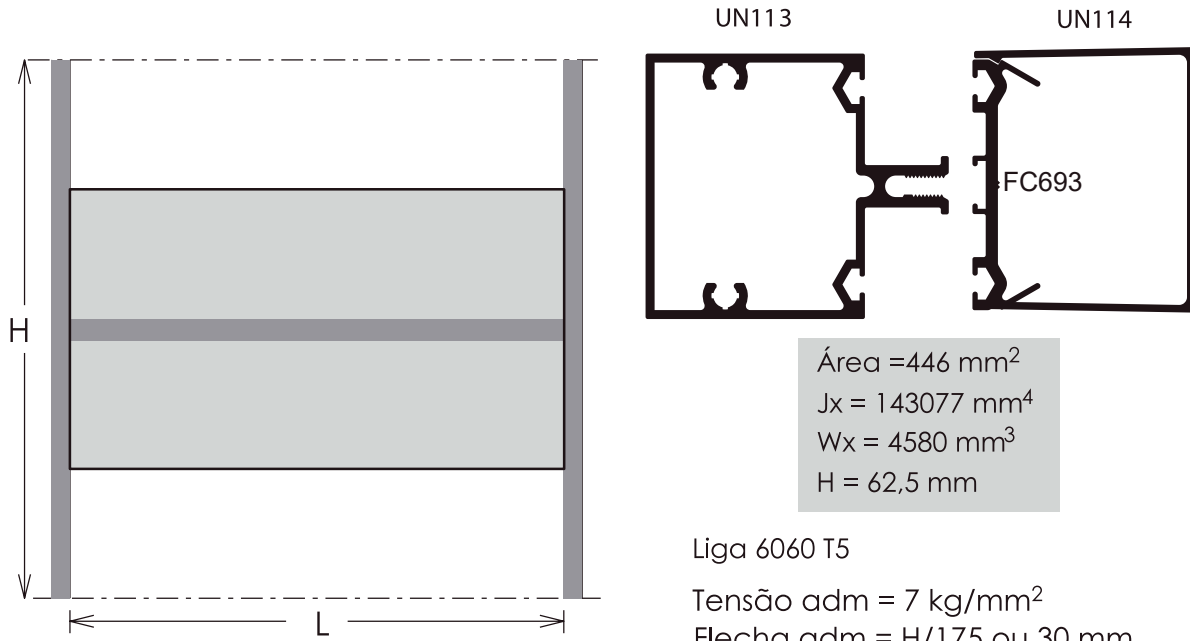

Área = 446 mm²
 Jx = 143077 mm⁴
 Wx = 4580 mm³
 H = 62,5 mm

Liga 6060 T5

Tensão adm = 7 kg/mm²

Flecha adm = H/175 ou 30 mm

Pressão de ensaio/Segurança (Pa)



Diagrama de Dimensões

UNIT - Módulo 100 - Encaixilhado

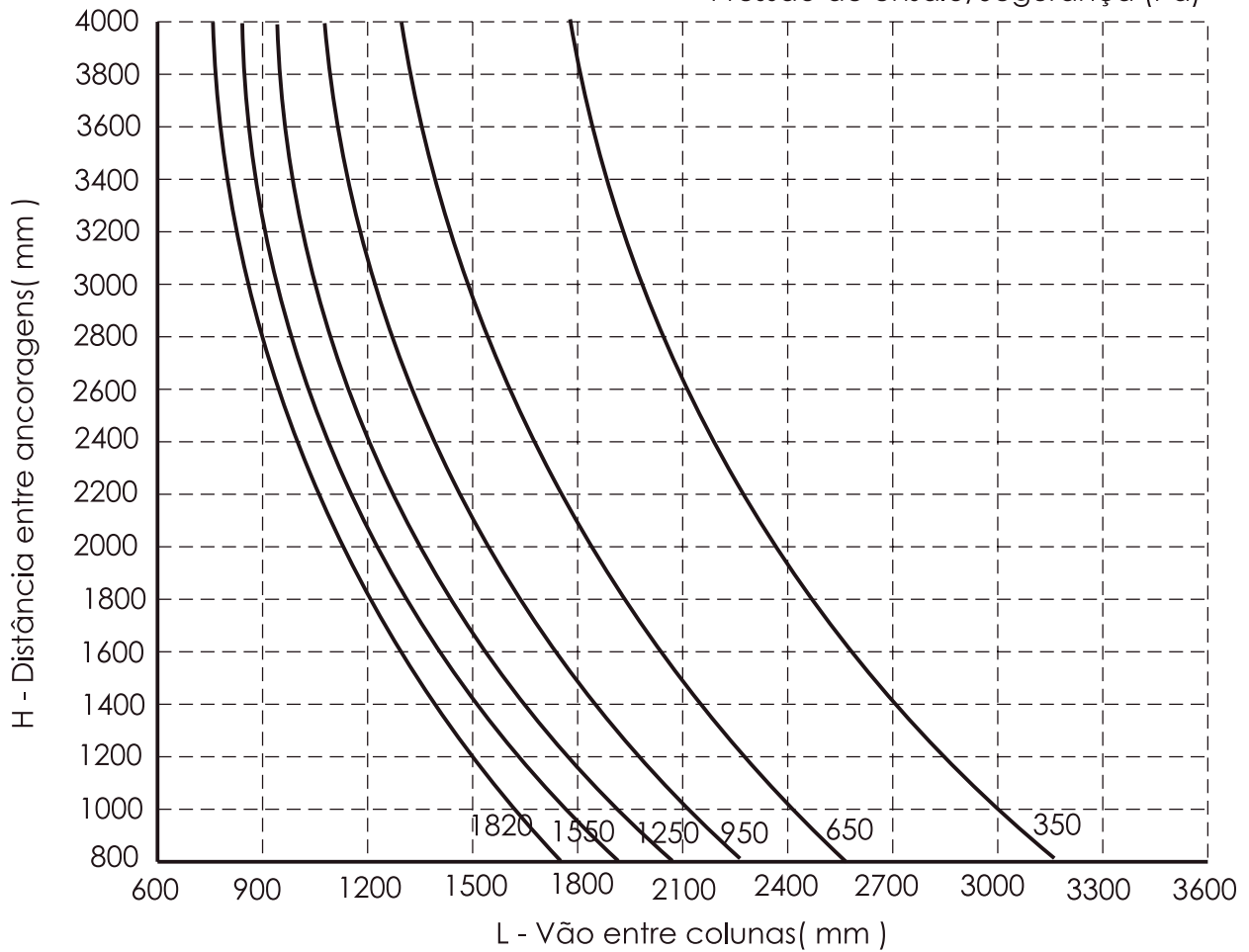
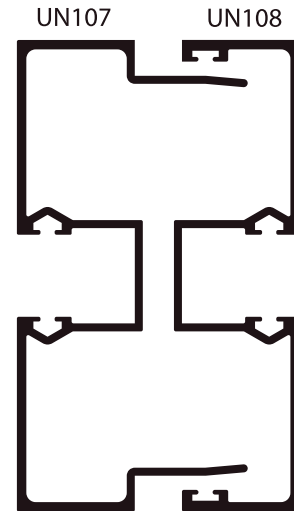
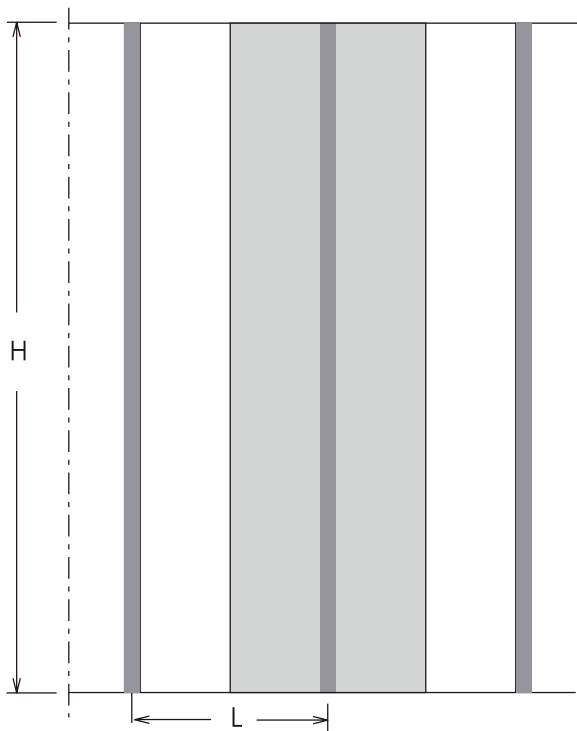

$\text{Área} = 940 \text{ mm}^2$
 $J_x = 1065572 \text{ mm}^4$
 $W_x = 21311 \text{ mm}^3$
 $H = 100 \text{ mm}$

Liga 6060 T5
 Tensão adm = 7 kg/mm^2
 Flecha adm = $H/175$ ou 30 mm
 Pressão de ensaio/Segurança (Pa)

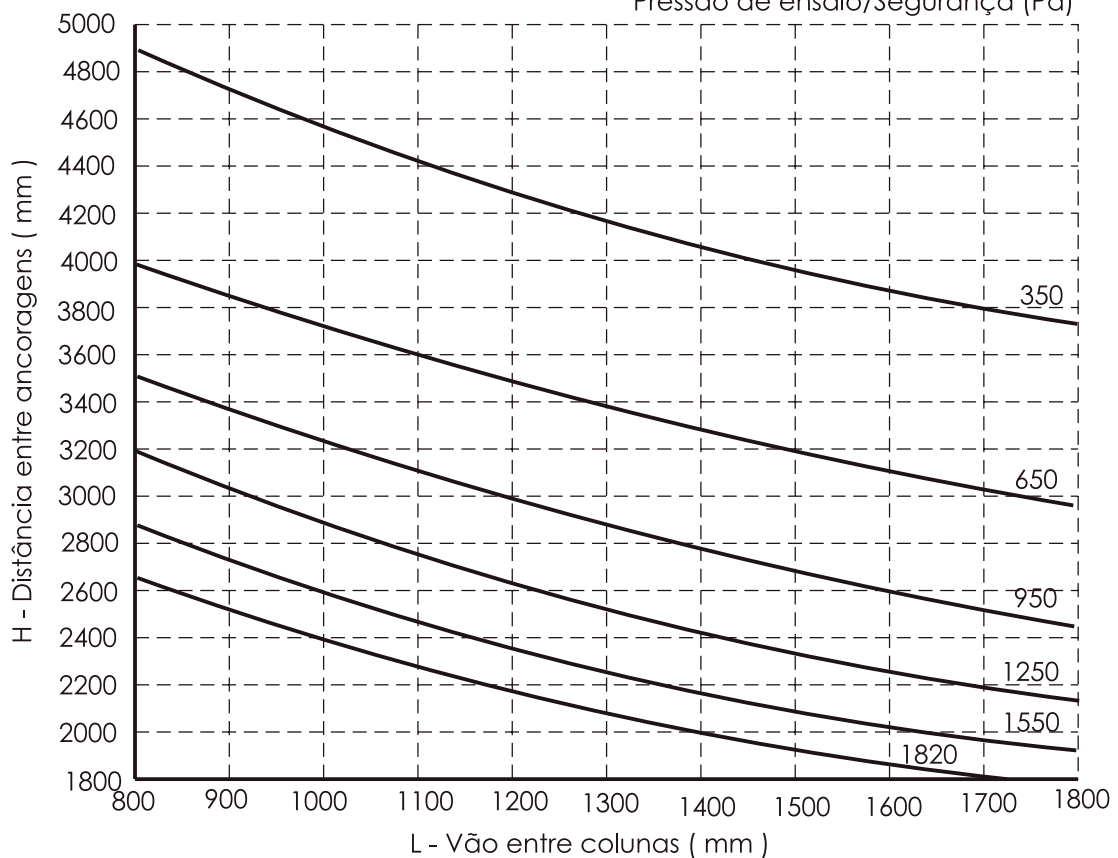

Perfis 100 Encaixilhado

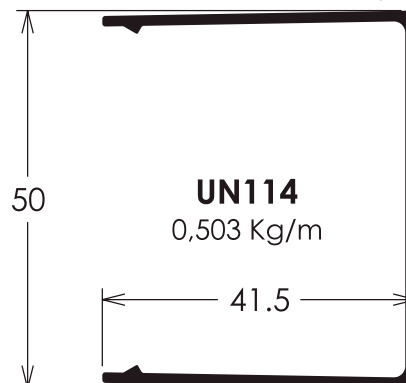
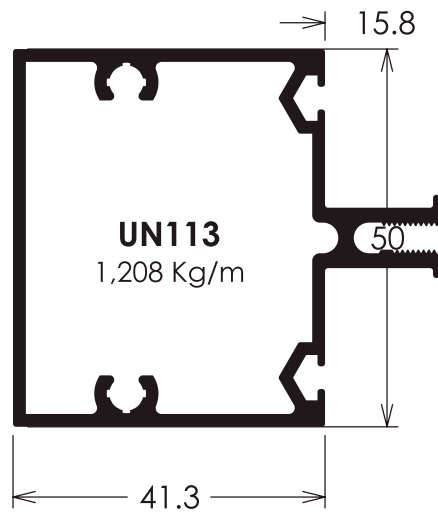
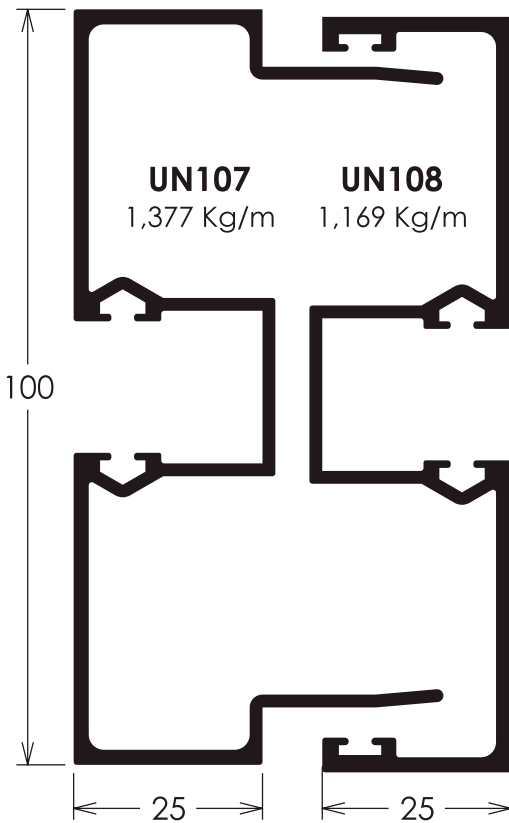
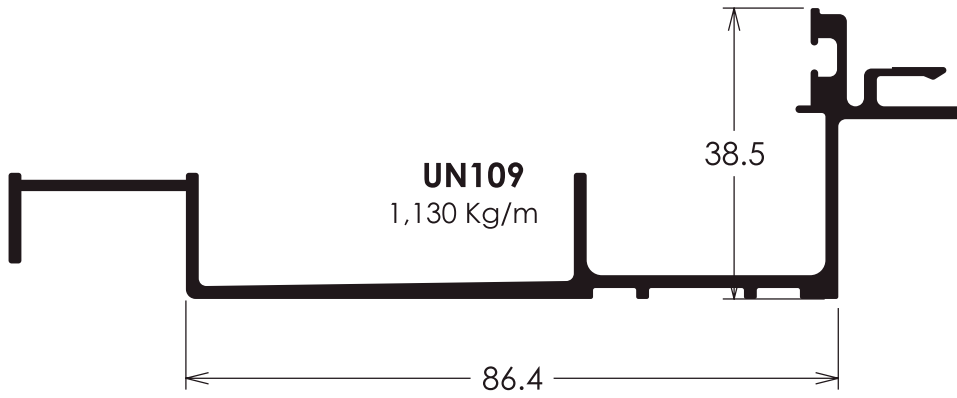
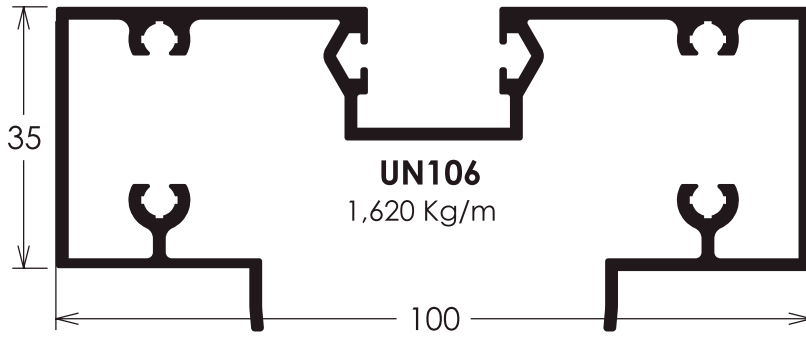

Projetos, perfis, componentes, códigos e sistemas estão sujeitos a alteração sem prévio aviso.

Perfis 100 Encaixilhado

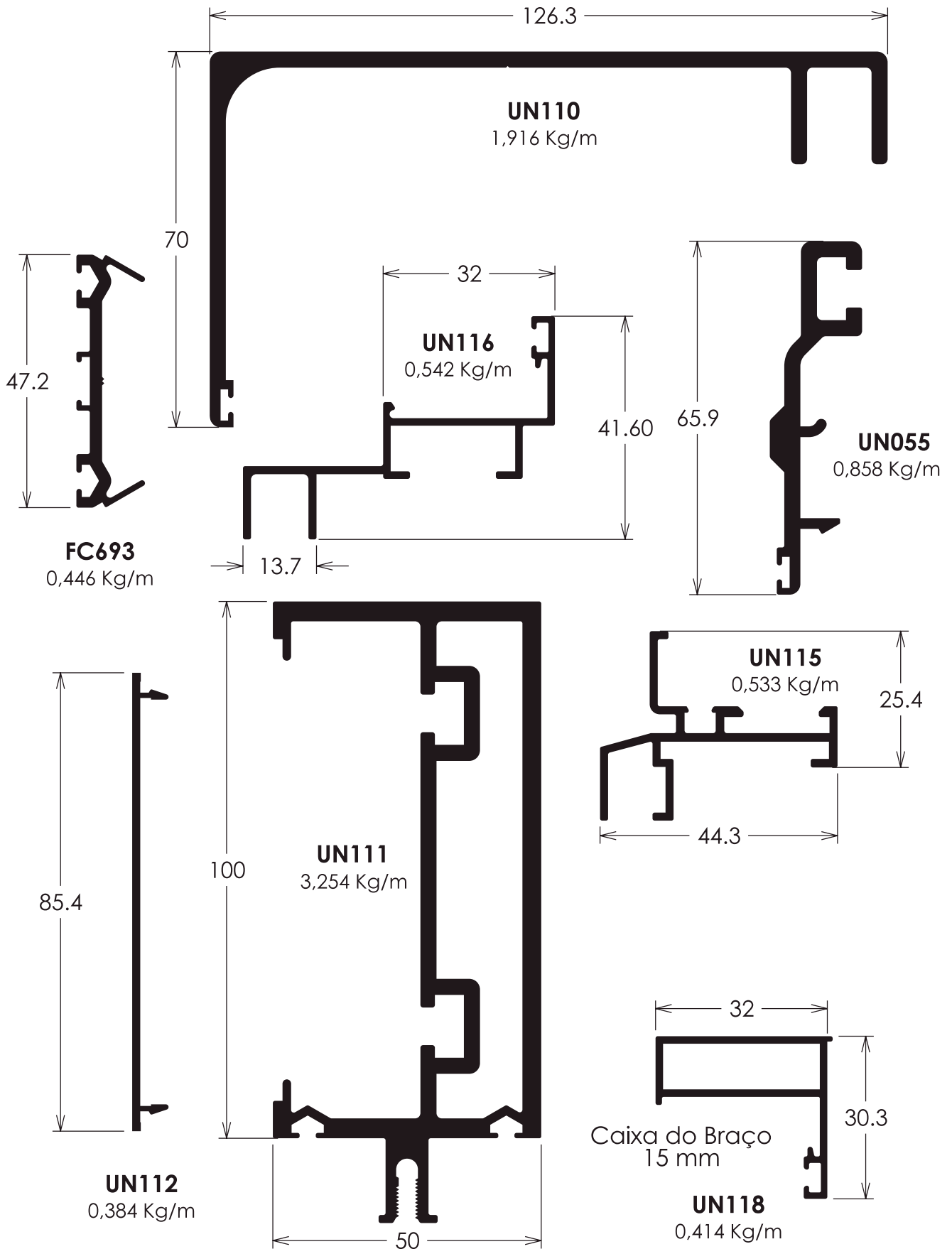

Projetos, perfis, componentes, códigos e sistemas estão sujeitos a alteração sem prévio aviso.

Módulo 120

FACHADA CONTÍNUA

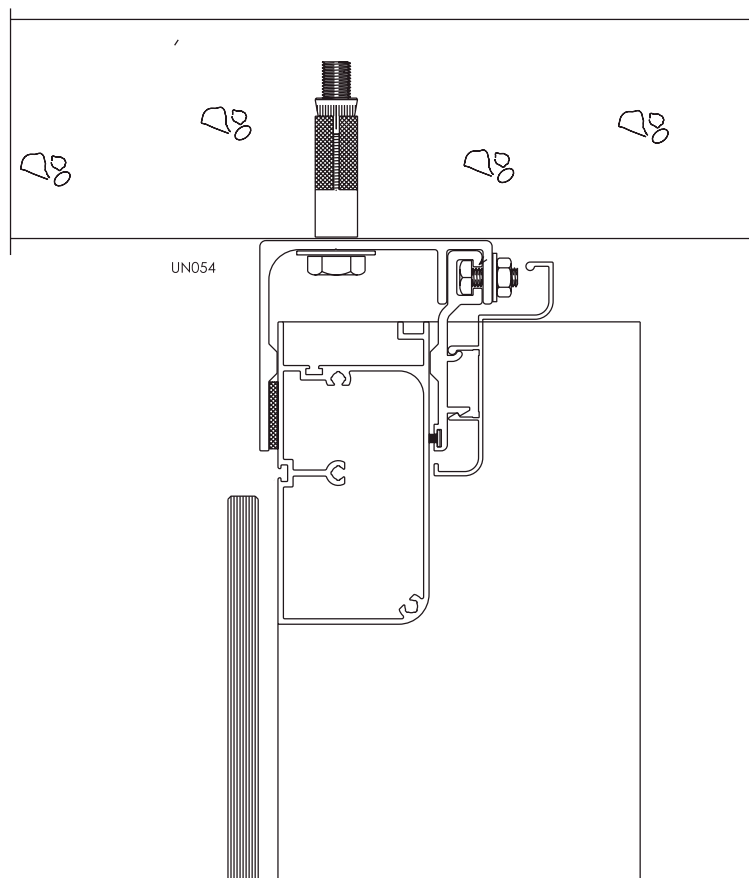

Montagem 120

ELEVAÇÃO VISTA PELO LADO EXTERNO

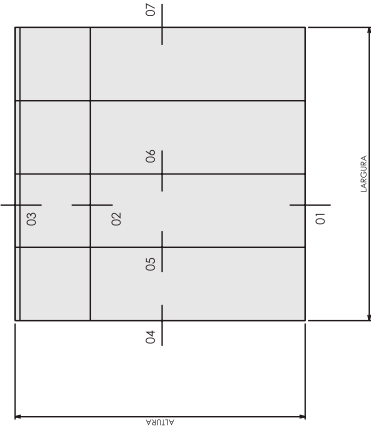

ATENÇÃO

A COLAGEM DOS VIDROS FITA DUPLA FACE OU SILICONE ESTRUTURAL, DEVERÁ SER FEITA, CONFORME AS ORIENTAÇÕES E TESTES DO PRODUTO, COM ACOMPANHAMENTO DO FORNECEDOR

TODAS AS GUIARNIÇÕES QUE FOREM CORTADAS A 45° DEVERÃO SER VULCANIZADAS OU COLADAS

NOTA: USAR SILICONE EM TODAS AS JUNÇÕES ENTRE PERIF.

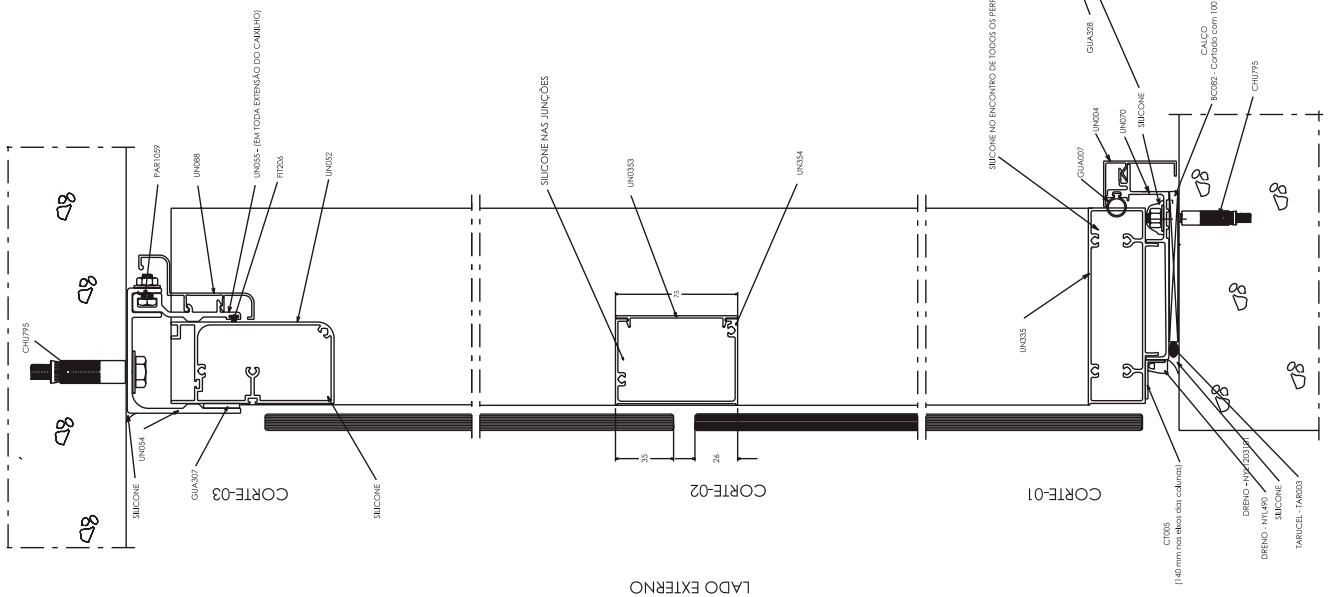

UNIT MÓDULO-FIXAÇÃO CONTÍNUA

Diagrama de Dimensões

Unit - Módulo de Fixação Contínua

Gráfico Correspondente ao Conjunto UN-337/338 e utilizando UN-0052/0054/0055 na parte superior

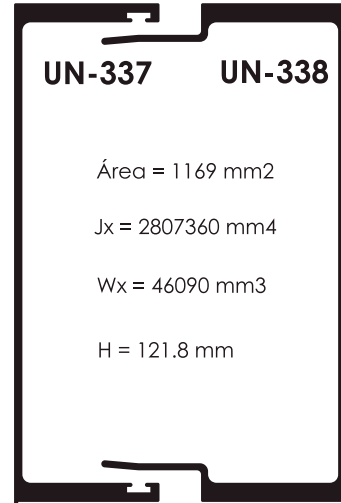
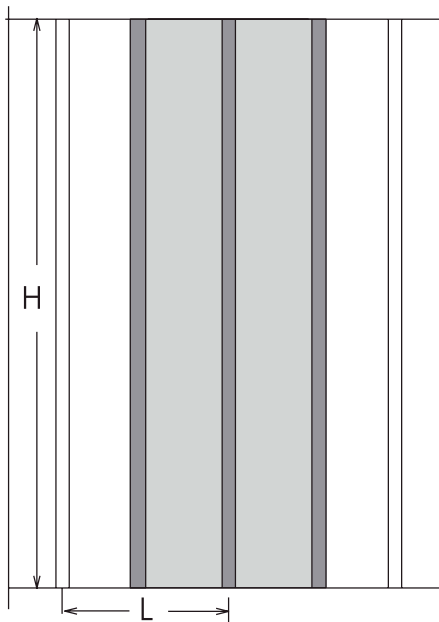

Liga 6060 T5
 Tensão adm = 7 kg/mm²
 Flecha adm = H/175 OU 30 mm

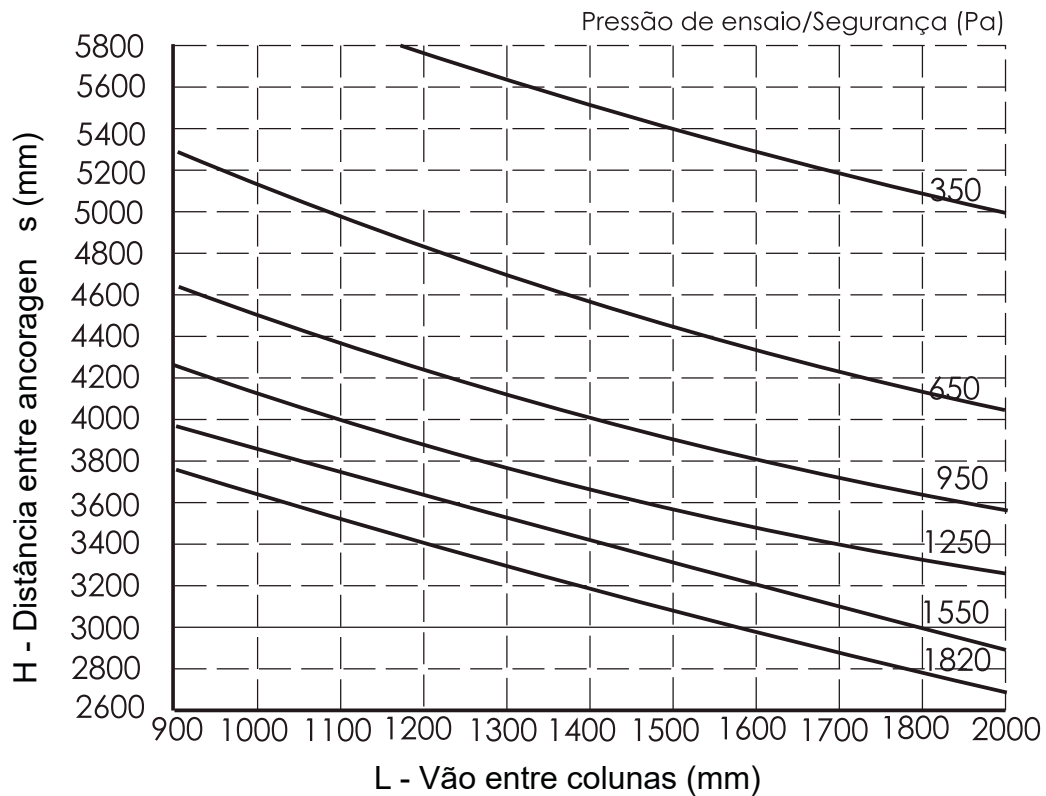

Perfis 120

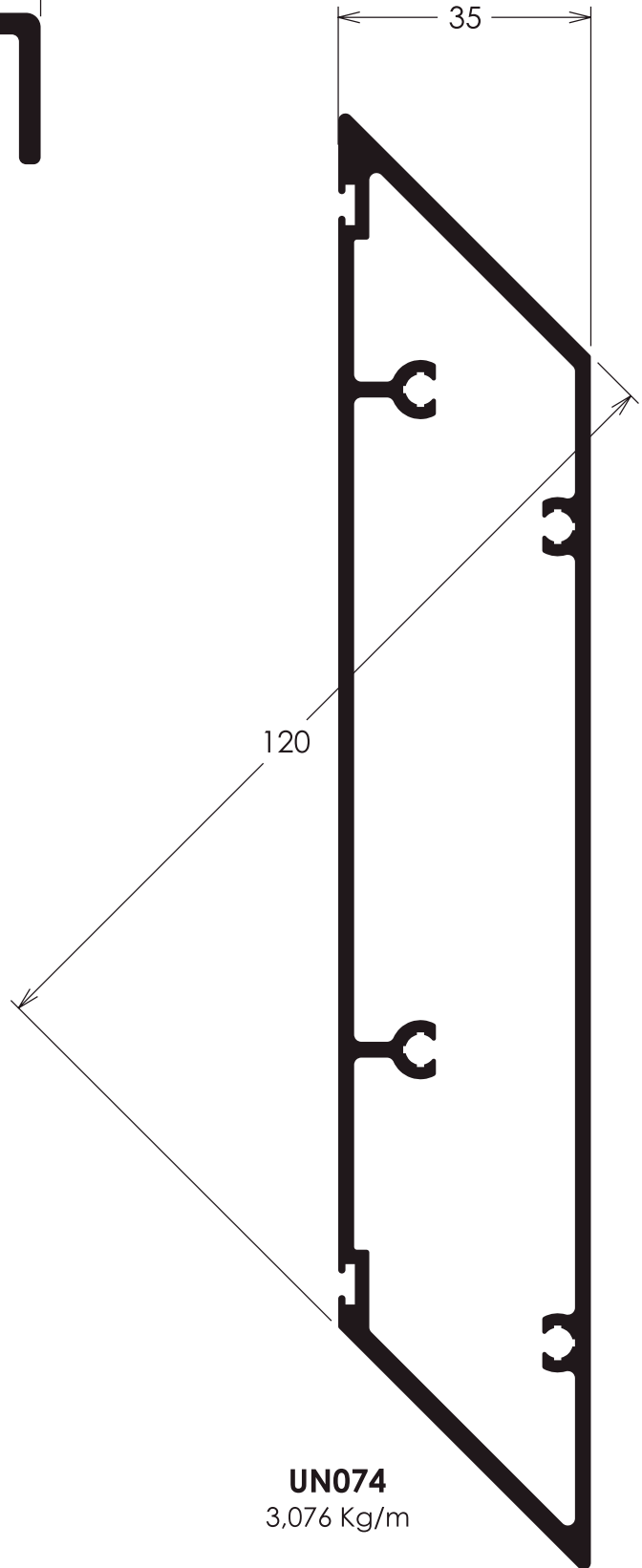
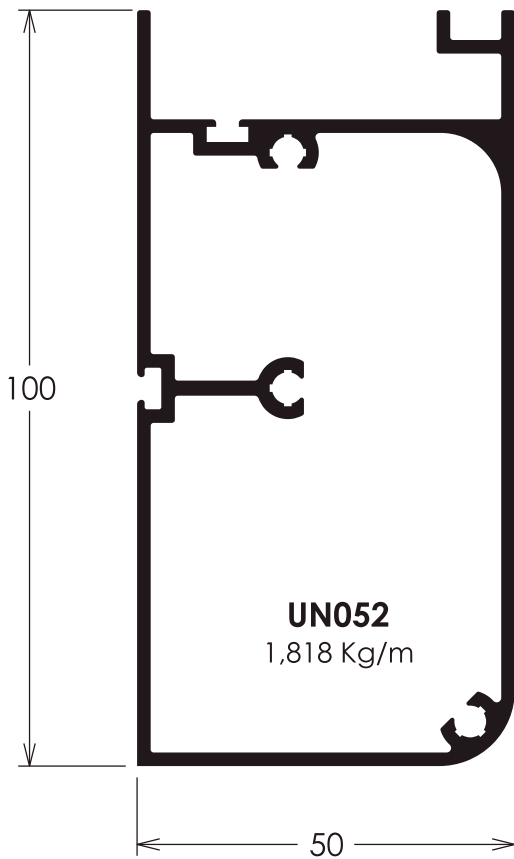
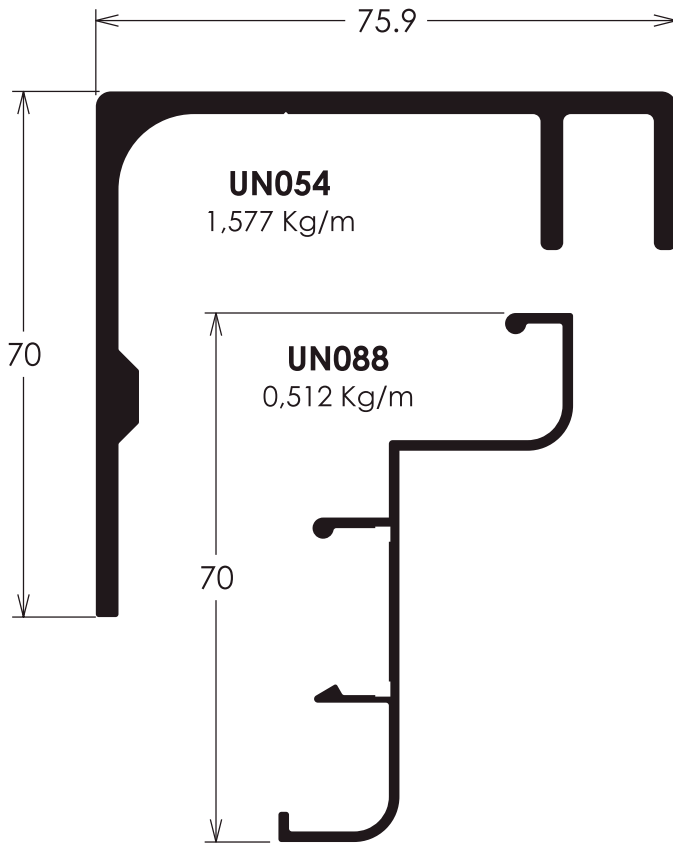

Projetos, perfis, componentes, códigos e sistemas estão sujeitos a alteração sem prévio aviso.

Perfis 120

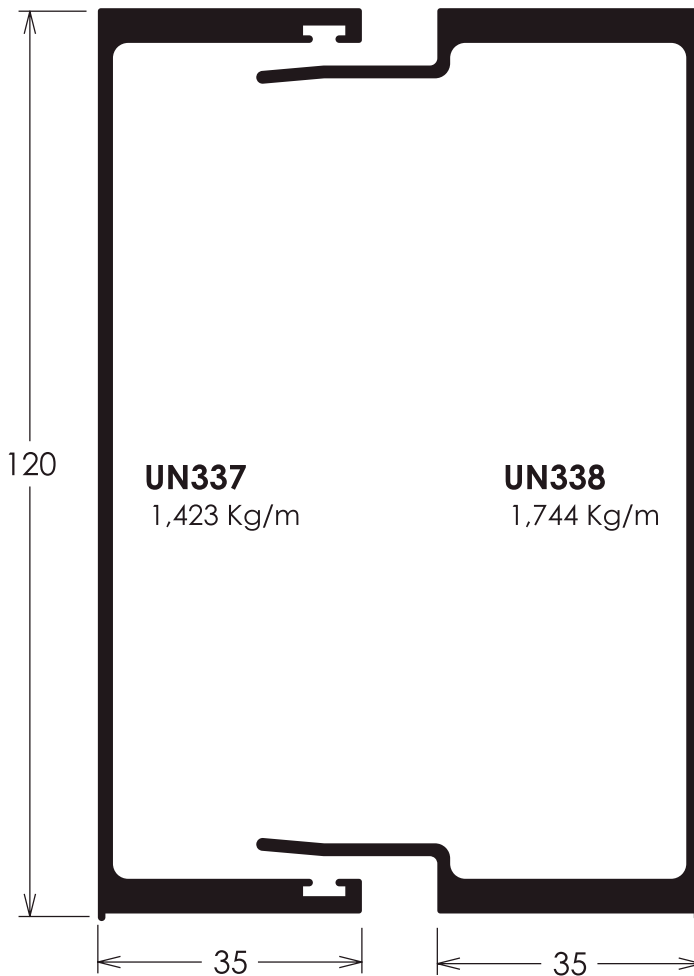
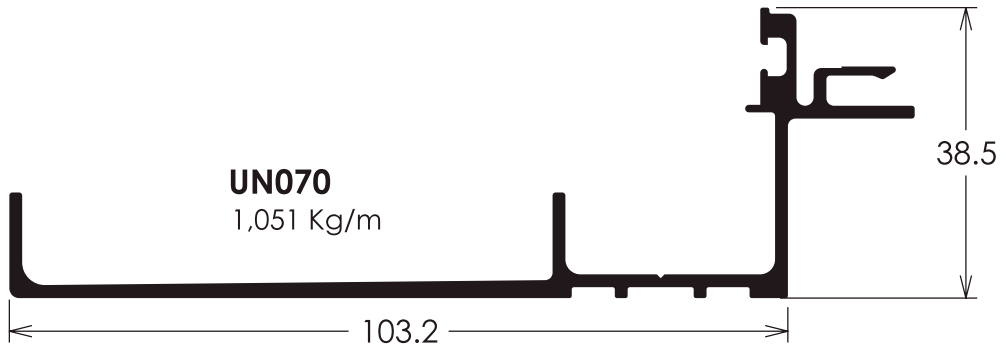
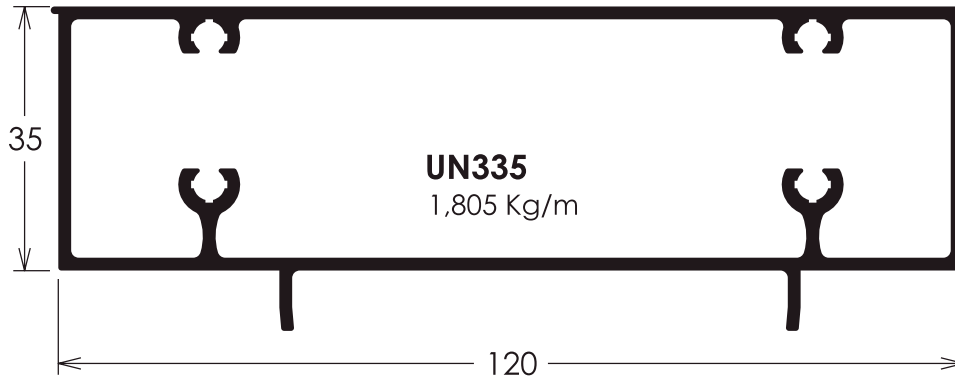

Projetos, perfis, componentes, códigos e sistemas estão sujeitos a alteração sem prévio aviso.

Módulo 120-35



Diagrama de Dimensões

UNIT - Módulo 120/35

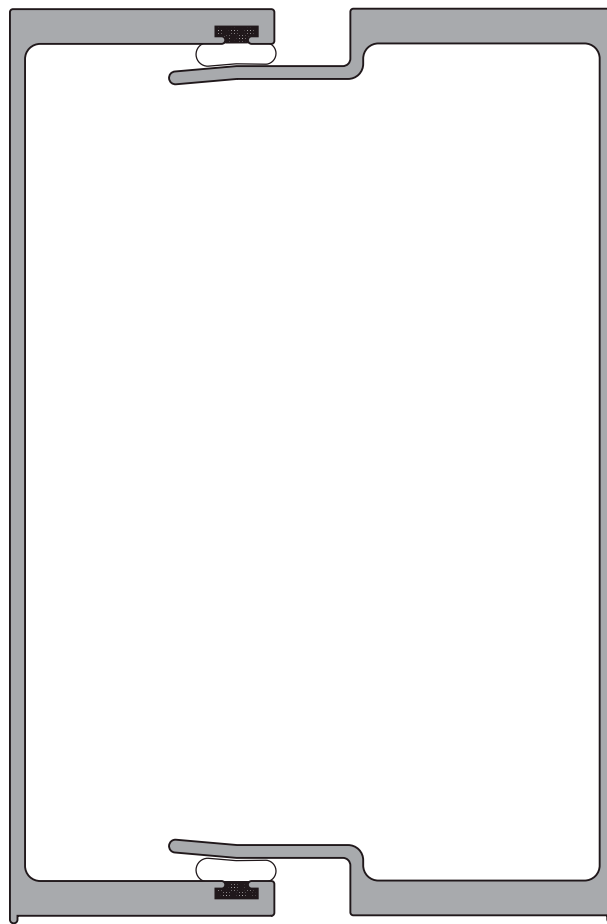
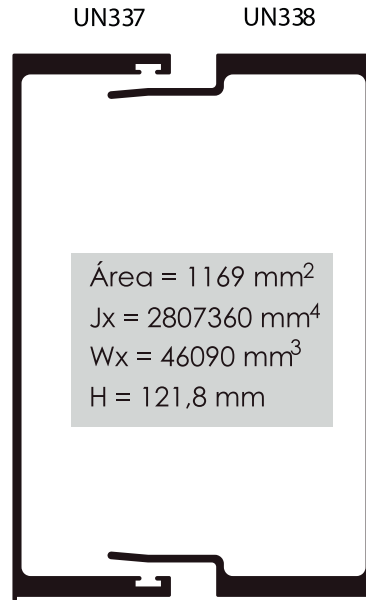
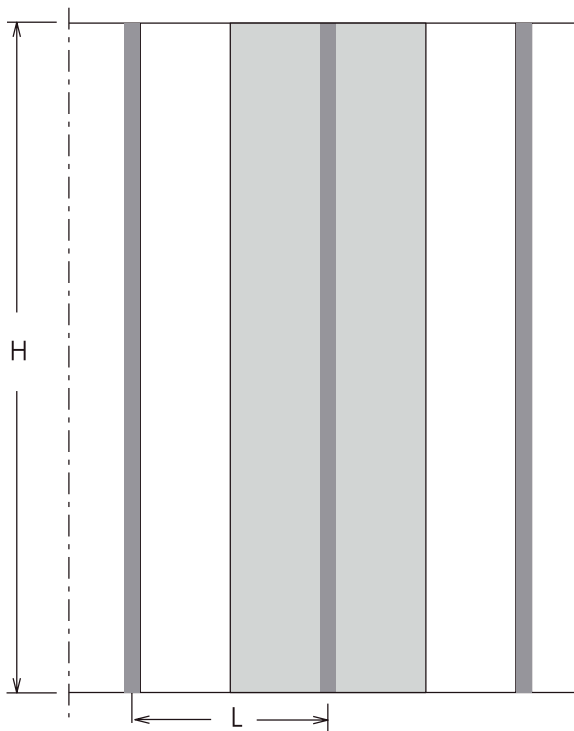

Área = 1169 mm²
 Jx = 2807360 mm⁴
 Wx = 46090 mm³
 H = 121,8 mm

Liga 6060 T5

Tensão adm = 7 kg/mm²

Flecha adm = H/175 OU 30 mm

Pressão de ensaio/Segurança (Pa)

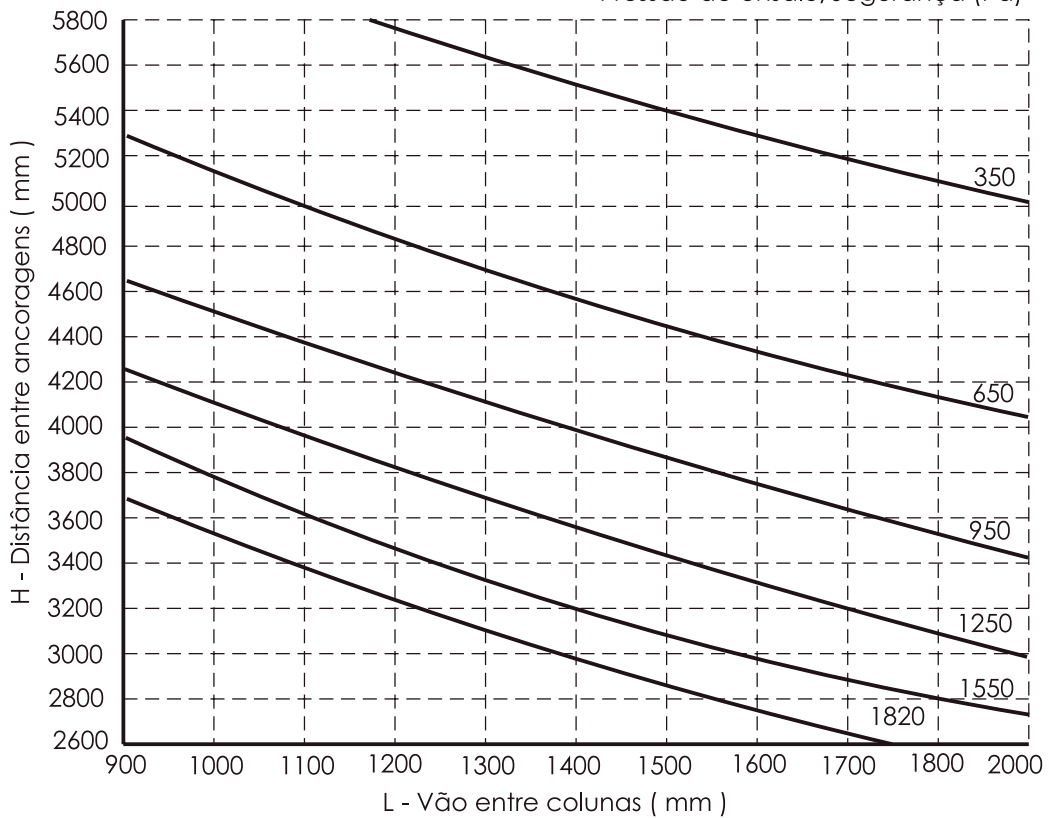

Perfis 120-35

UN072

0,666 kg/m

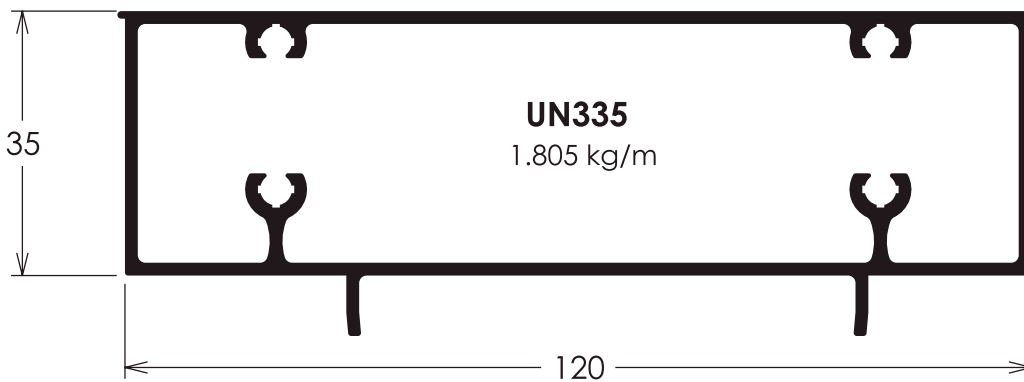
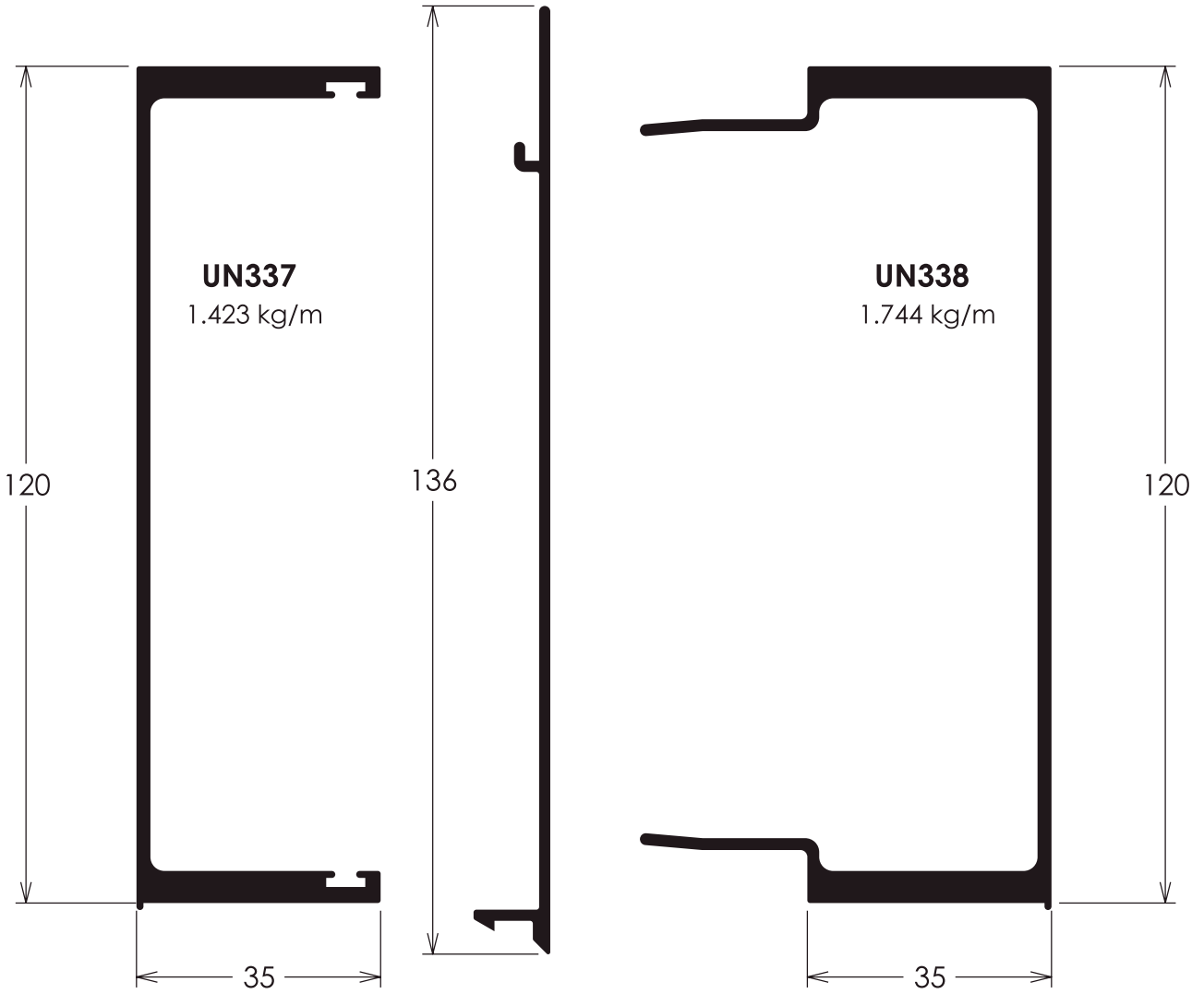

Perfis 120-35

Componentes de encaixe=ANC1000 / ANC1001 P/ UN017

Componentes de encaixe=ANC1004 / ANC1005 P/ UN129

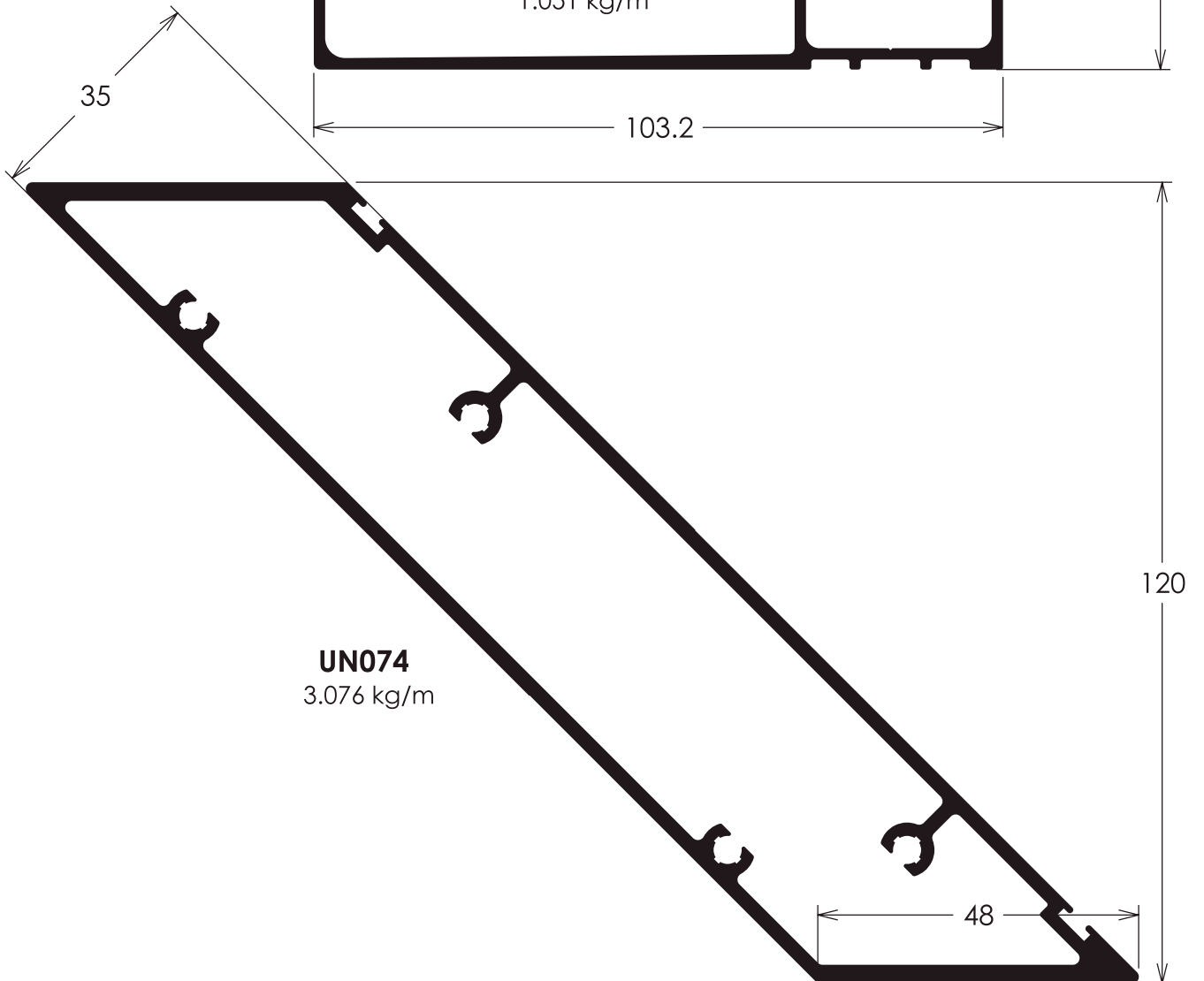
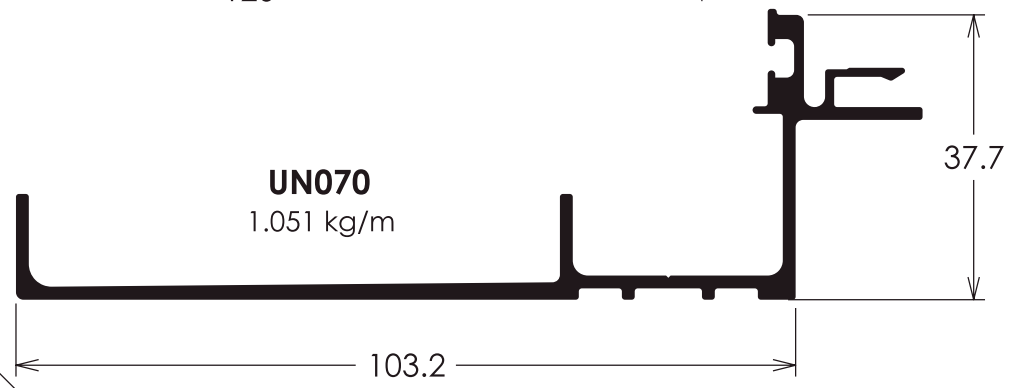
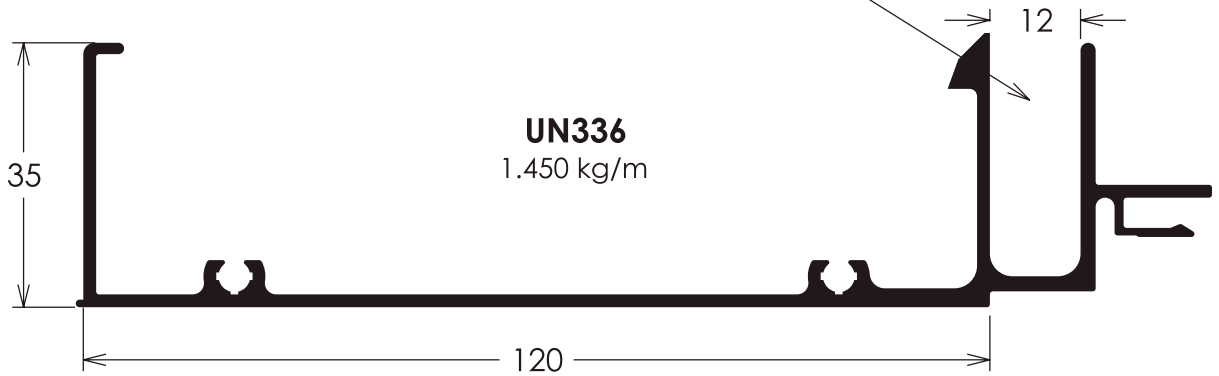

Módulo Fachada 80

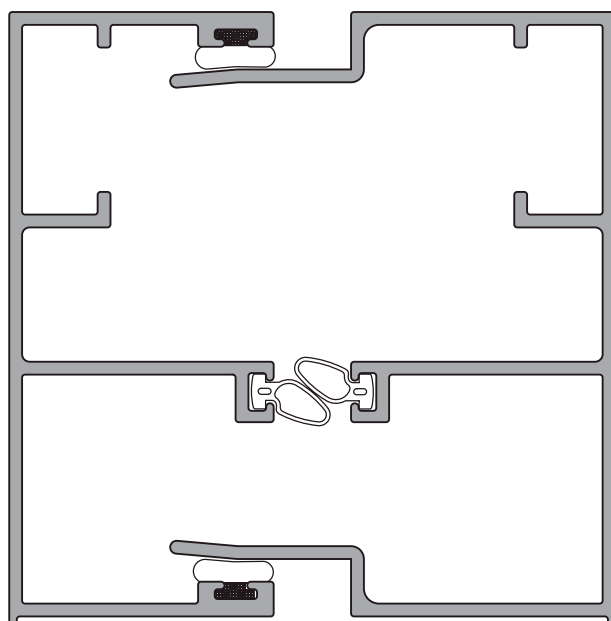

Montagem Fachada 80

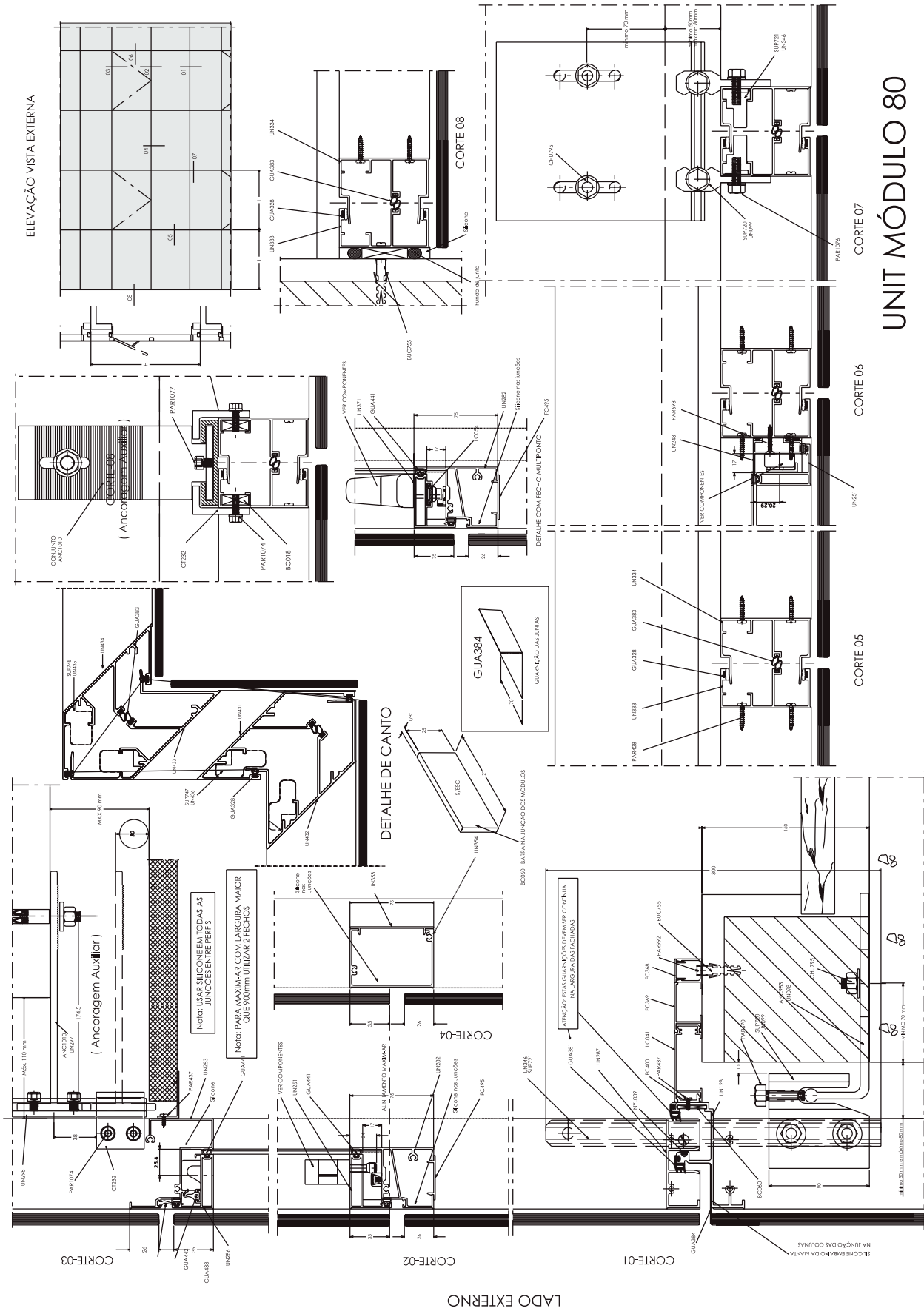

Montagem Fachada 80

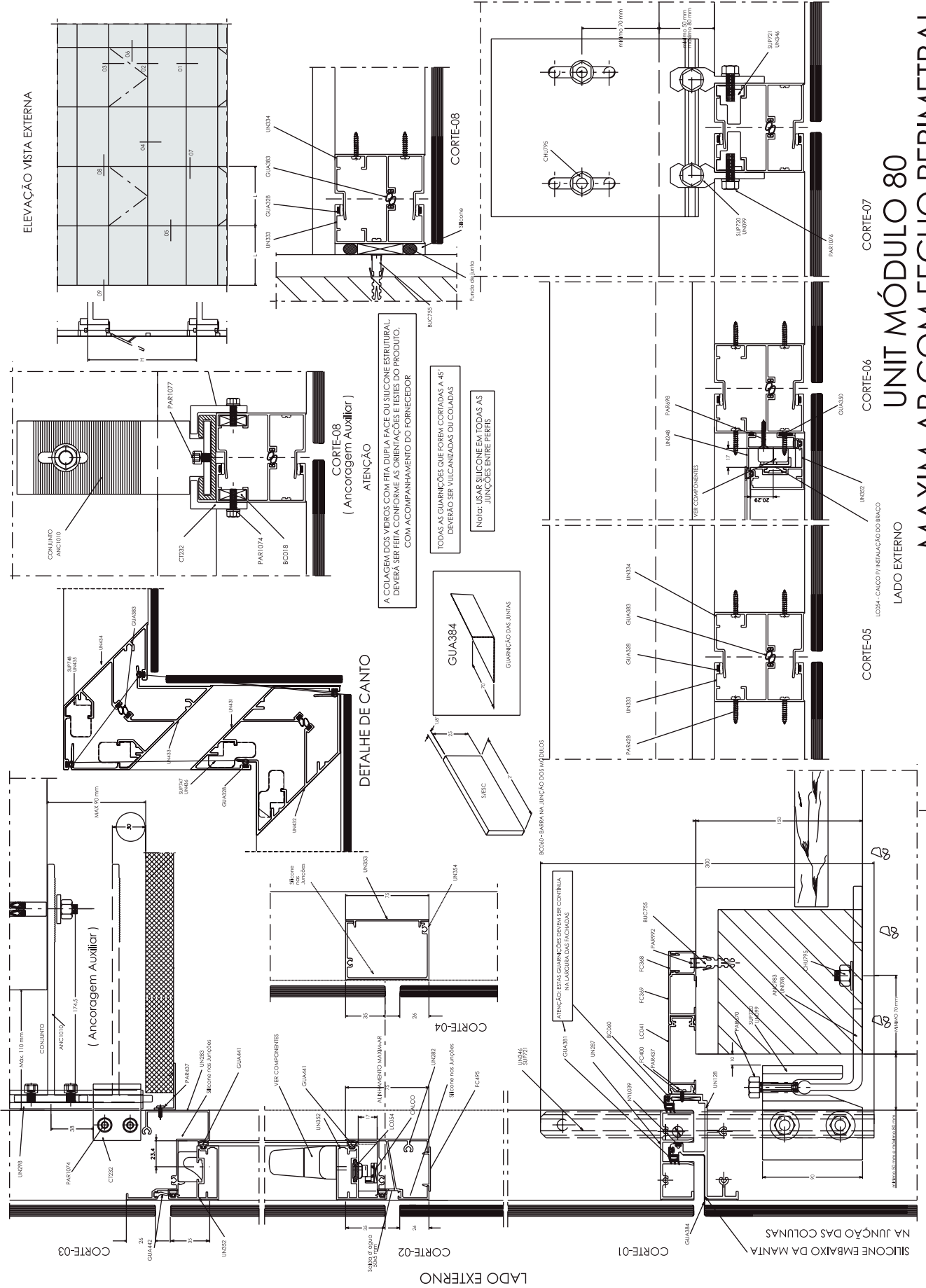

UNIT MÓDULO 80 MAXIM-AR COM FECHO PERIMETRAL

Diagrama de Dimensões

UNIT - Módulo Fachada 80 Auxiliar

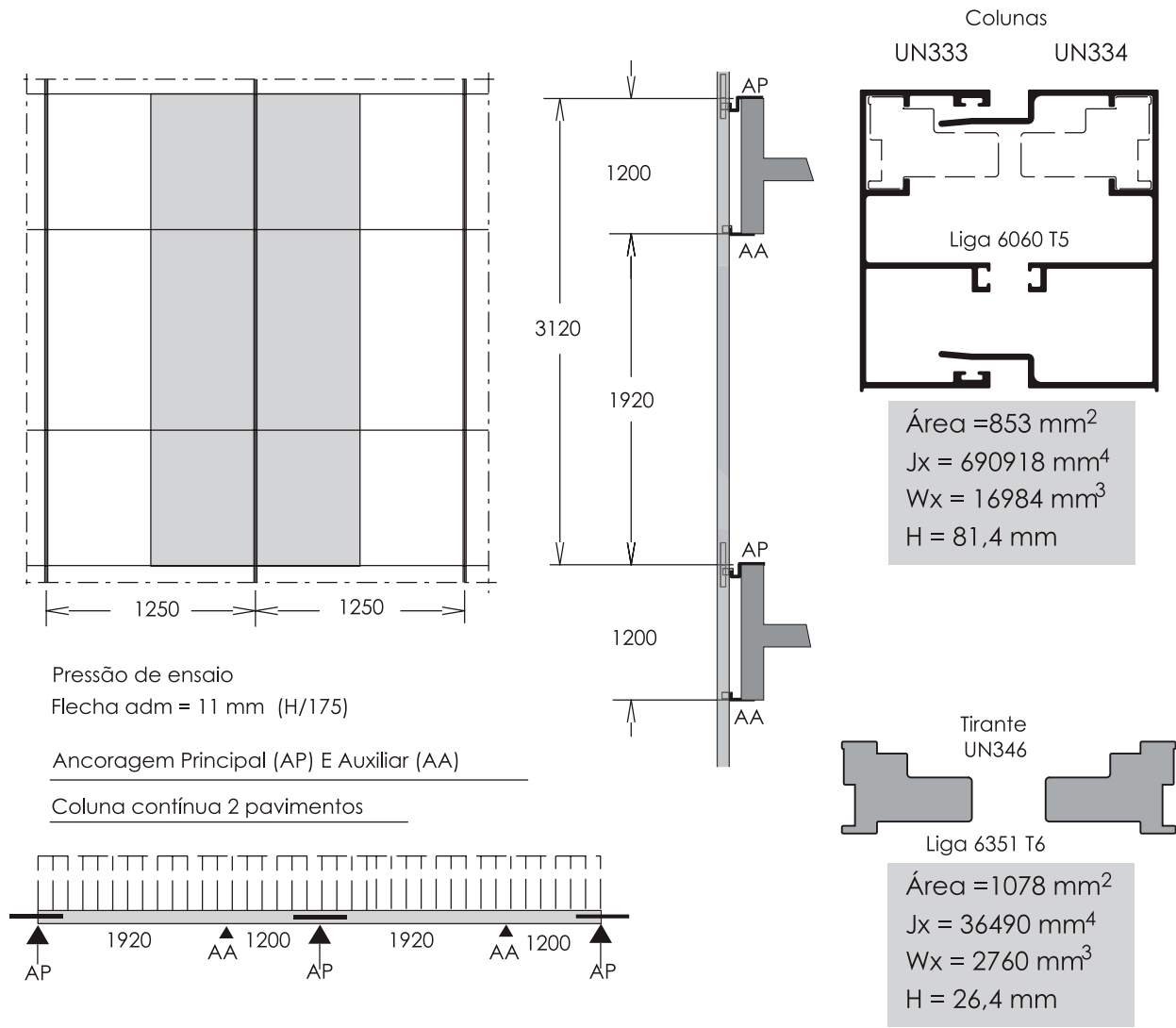

Importante: Consultar o fabricante do vidro para determinar a espessura em função da pressão de segurança

Liga 6060 T5
 Tensão adm = 7 kg/mm²
 Liga 6351 T6
 Tensão adm = 15 kg/mm²

Conclusão: Pela norma NBR 10821 - 2011, o conjunto (coluna-luva) com ancoragens principais e auxiliares, atende:

Pressão de ensaio máxima = 1630 Pa Pressão de segurança = 2440 Pa

Condição de utilização: 30 pavimentos ou 90 m na região IV
 20 pavimentos ou 60 m na região V

Perfis Fachada 80

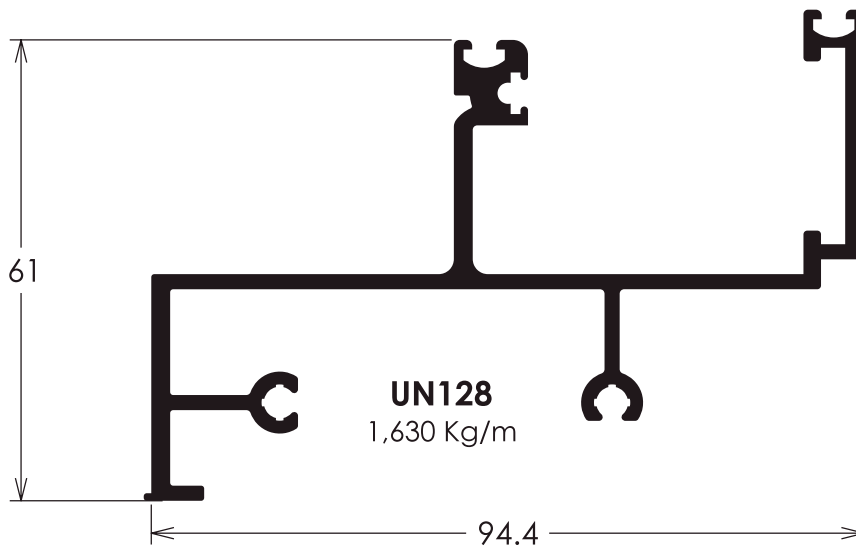
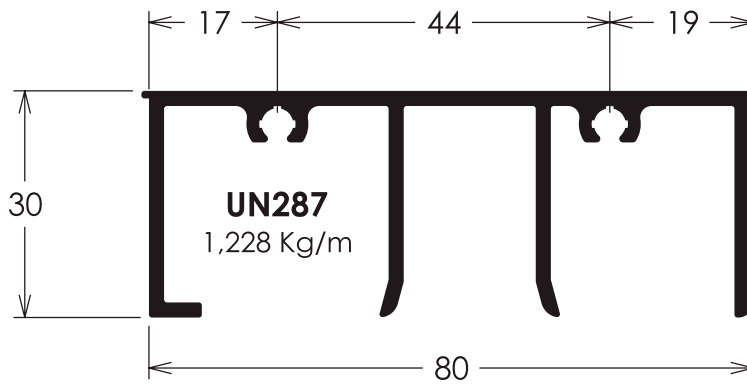
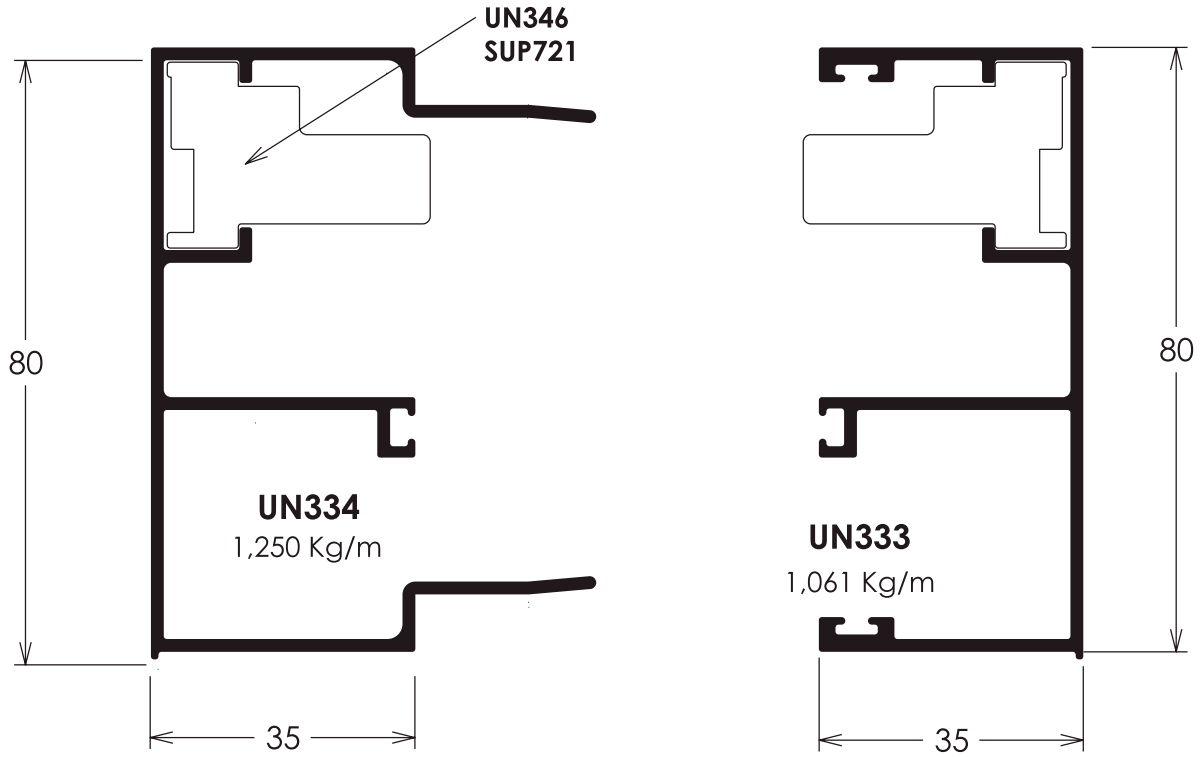

Perfis Fachada 80

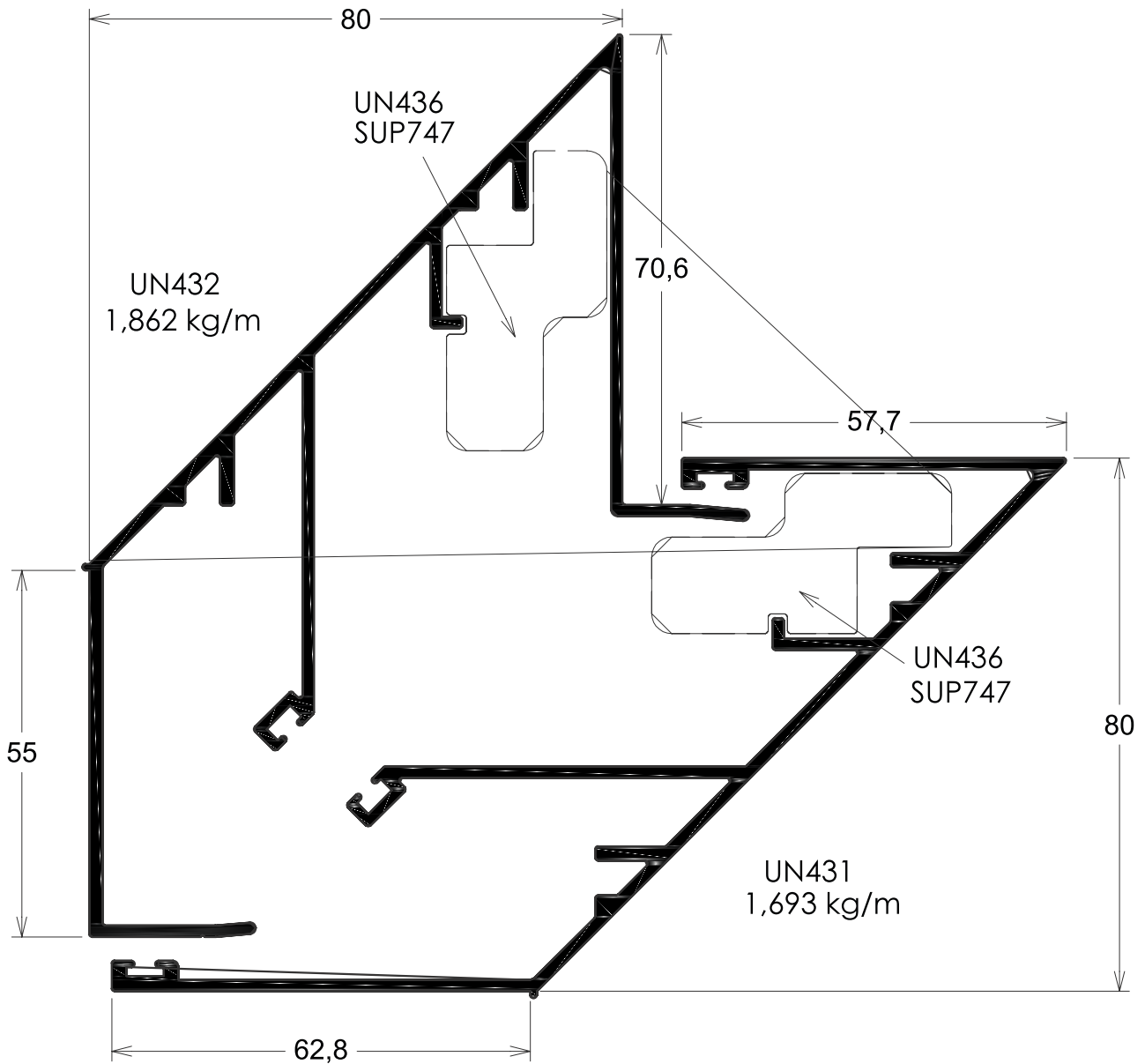

Perfis Fachada 80

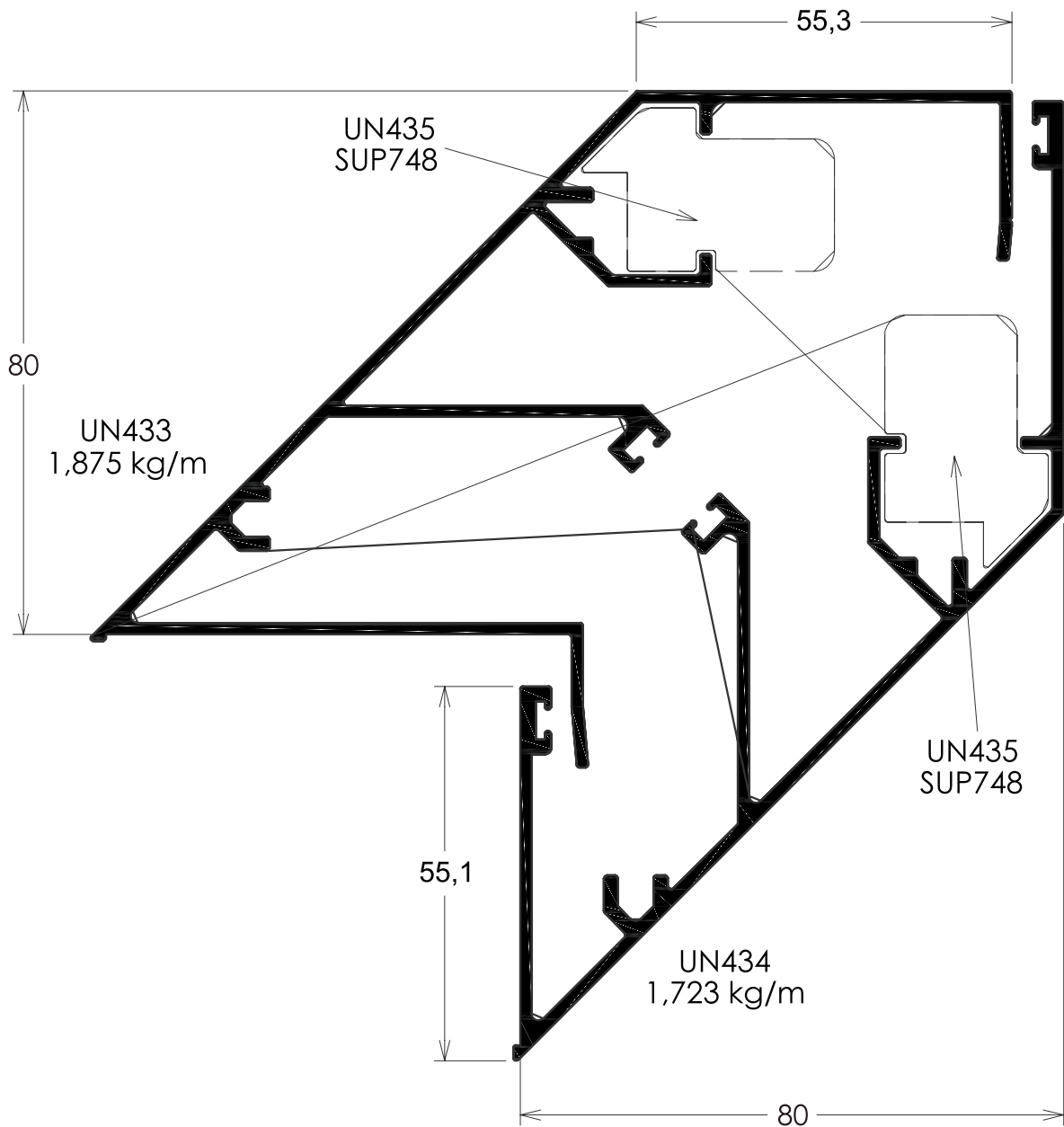

Perfis Fachada 80

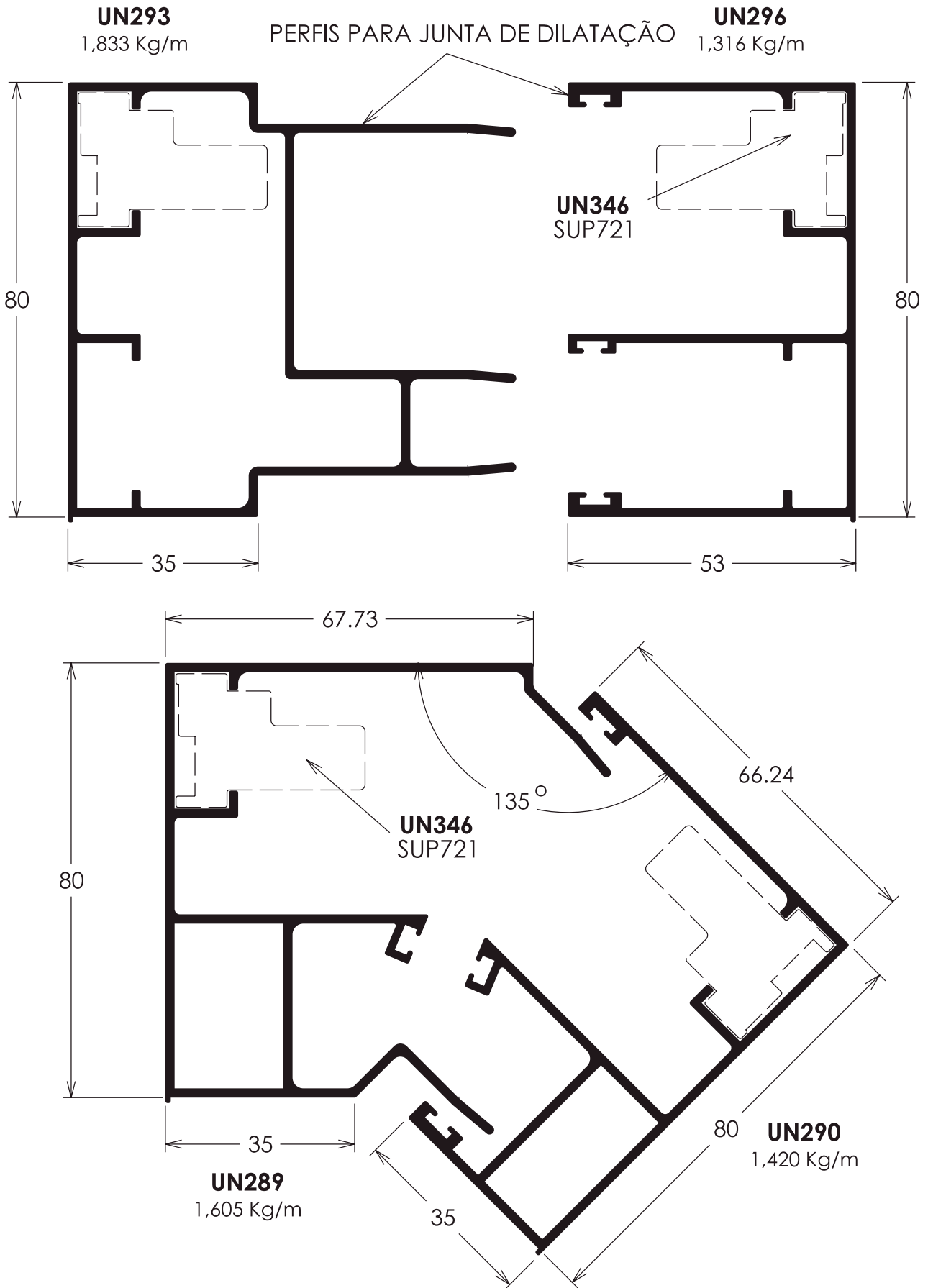

Módulo Fachada 100

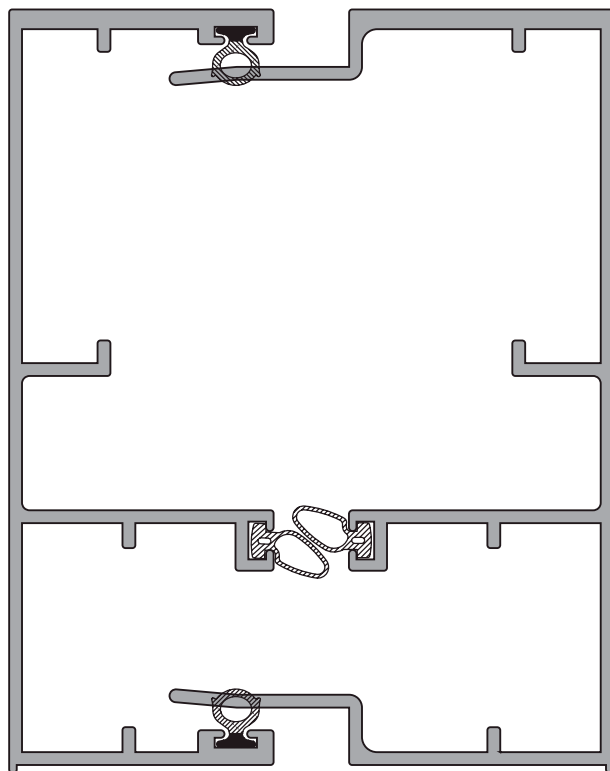

Montagem Fachada 100

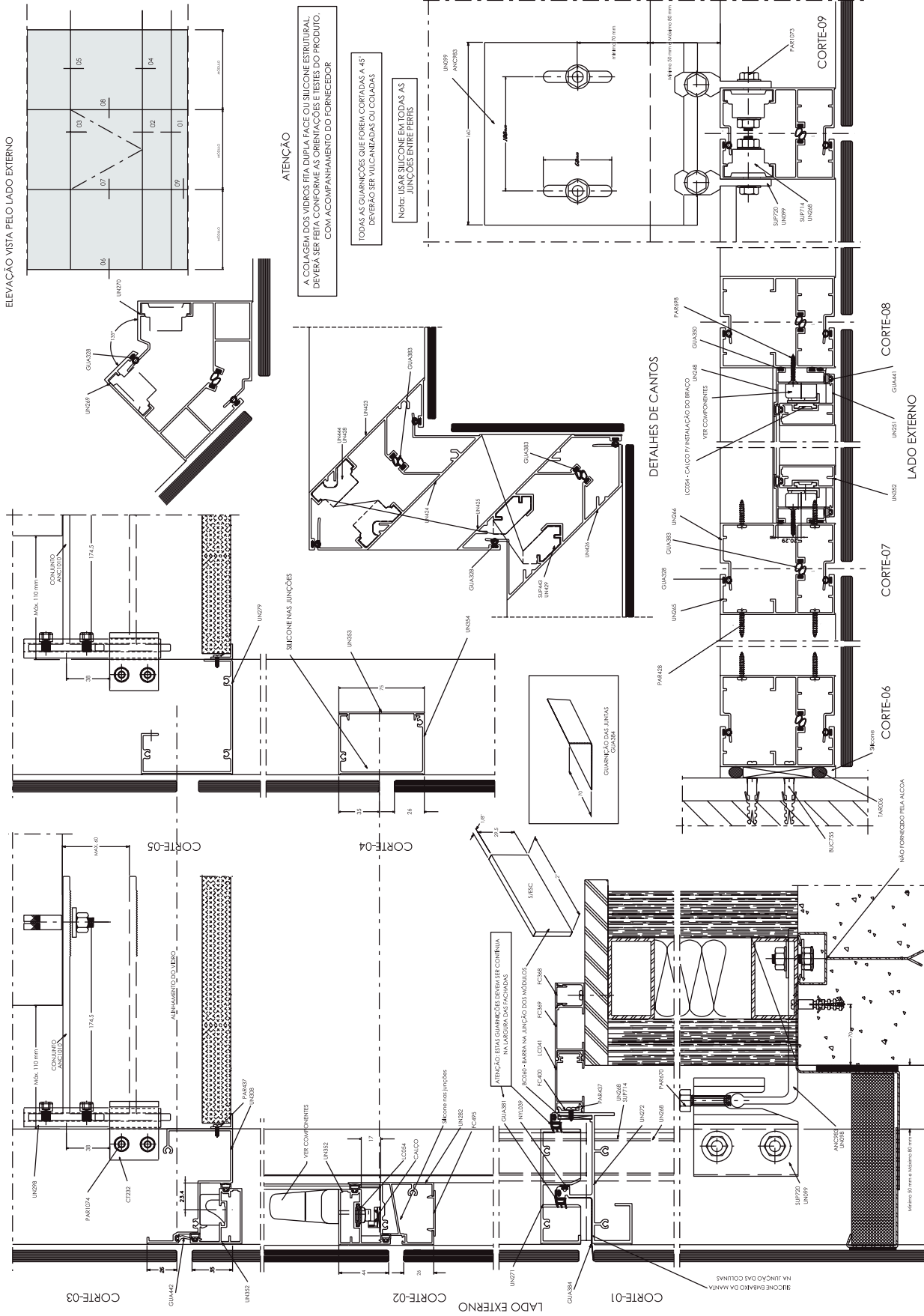

UNIT MÓDULO-100 FACHADA MAXIM-AR COM FECHO PERIMETRAL

Diagrama de Dimensões

UNIT - Módulo Fachada 100 Auxiliar

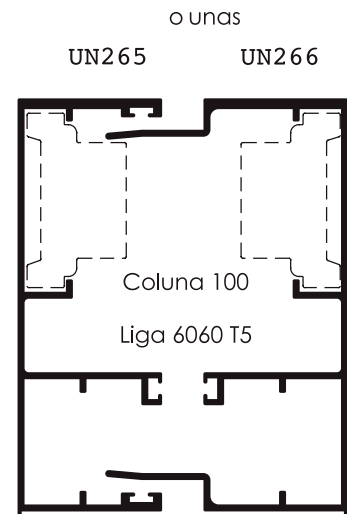
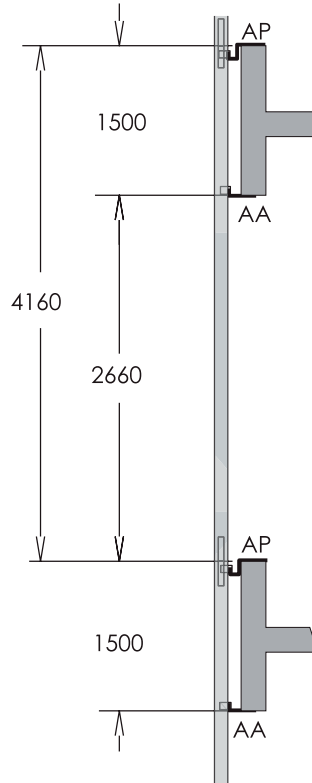
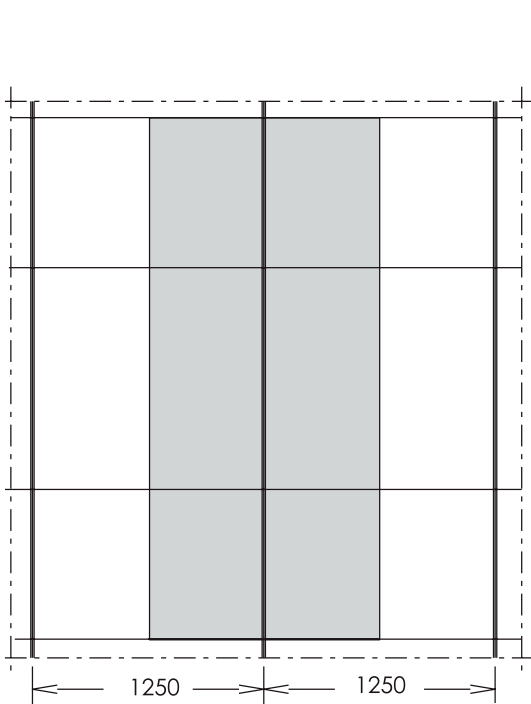

$\text{Área} = 990 \text{ mm}^2$
 $J_x = 1317510 \text{ mm}^4$
 $W_x = 26074 \text{ mm}^3$
 $H = 101 \text{ mm}$

Pressão de ensaio
 $\text{Flecha adm} = 15.2 \text{ mm (H/175)}$
 Ancoragem principal (AP) e auxiliar (AA)
 Coluna contínua 2 pavimentos

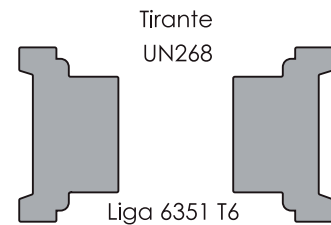
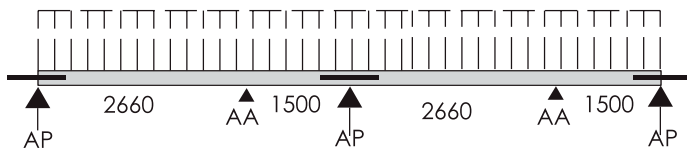

$\text{Área} = 1450 \text{ mm}^2$
 $J_x = 165137 \text{ mm}^4$
 $W_x = 7826 \text{ mm}^3$
 $H = 42,2 \text{ mm}$

Importante: Consultar o fabricante do vidro para determinar a espessura em função da pressão de segurança

Liga 6351 T6
 $\text{Tensão adm} = 15 \text{ kg/mm}^2$
 Liga 6060 T5
 $\text{Tensão adm} = 7 \text{ kg/mm}^2$

Conclusão: Pela norma NBR 10821 - 2011, o conjunto (coluna-luva) com ancoragens principais e auxiliares, atende:
 $\text{Pressão de ensaio máxima} = 2050 \text{ Pa}$ $\text{Pressão de segurança} = 3070 \text{ Pa}$
 Condição de utilização: 30 pavimentos ou 90 m na região V

Perfis Fachada 100

UN271
1,482 Kg/m

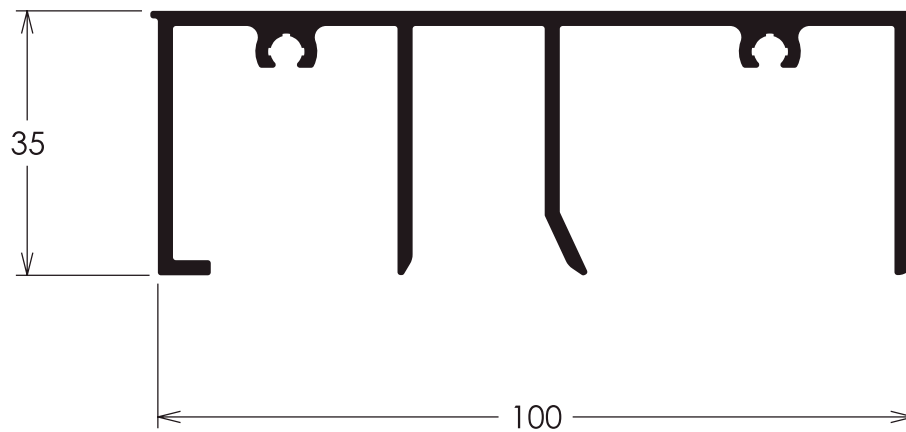

UN272
2,053 Kg/m

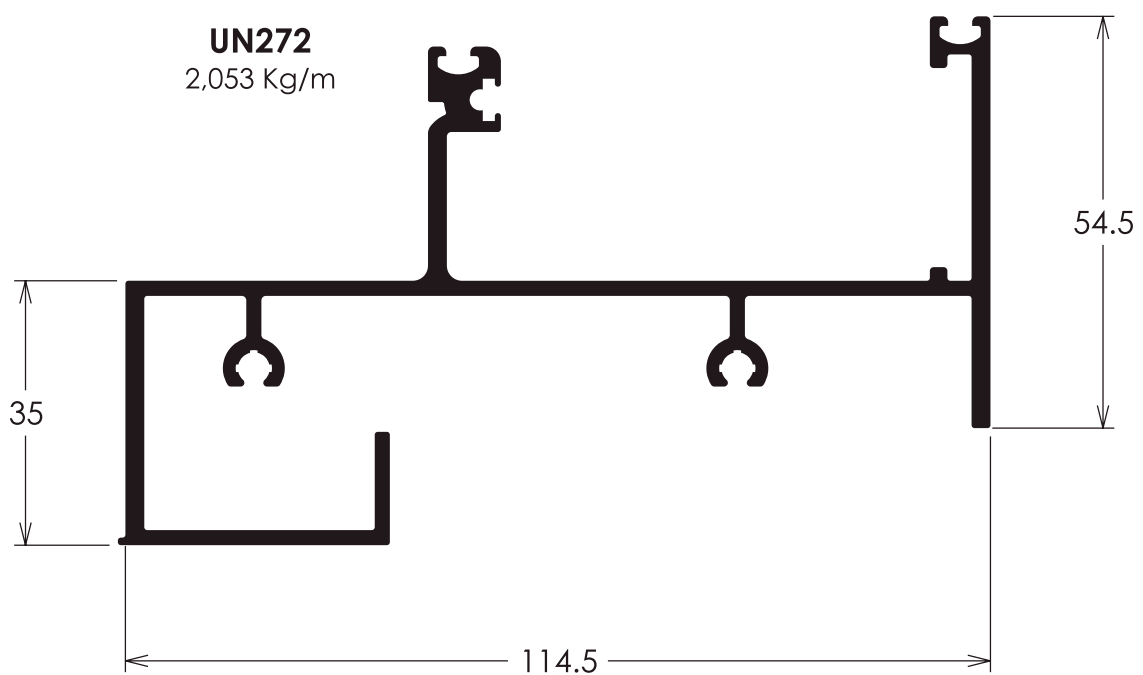

Perfis Fachada 100

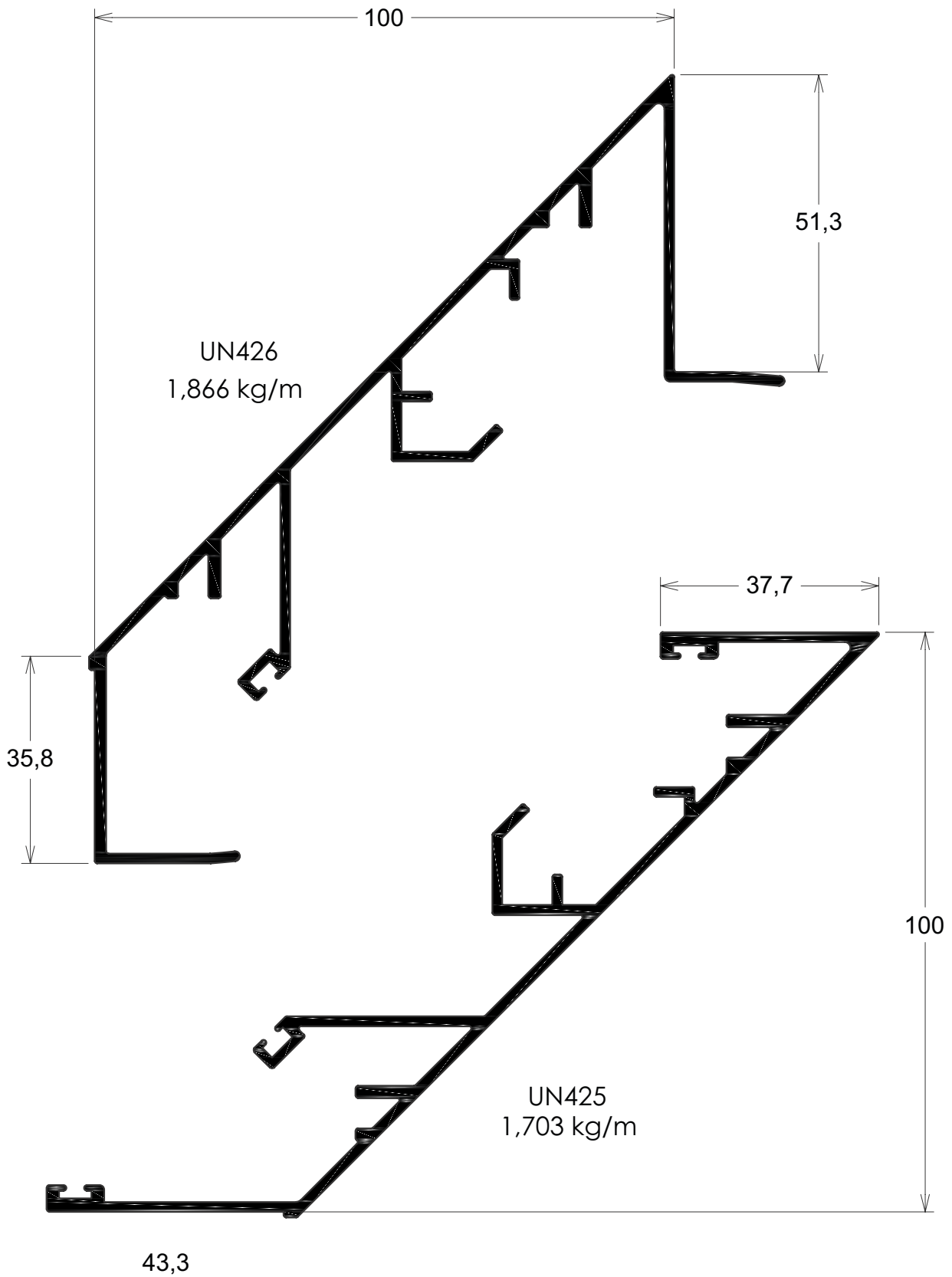

Perfis Fachada 100

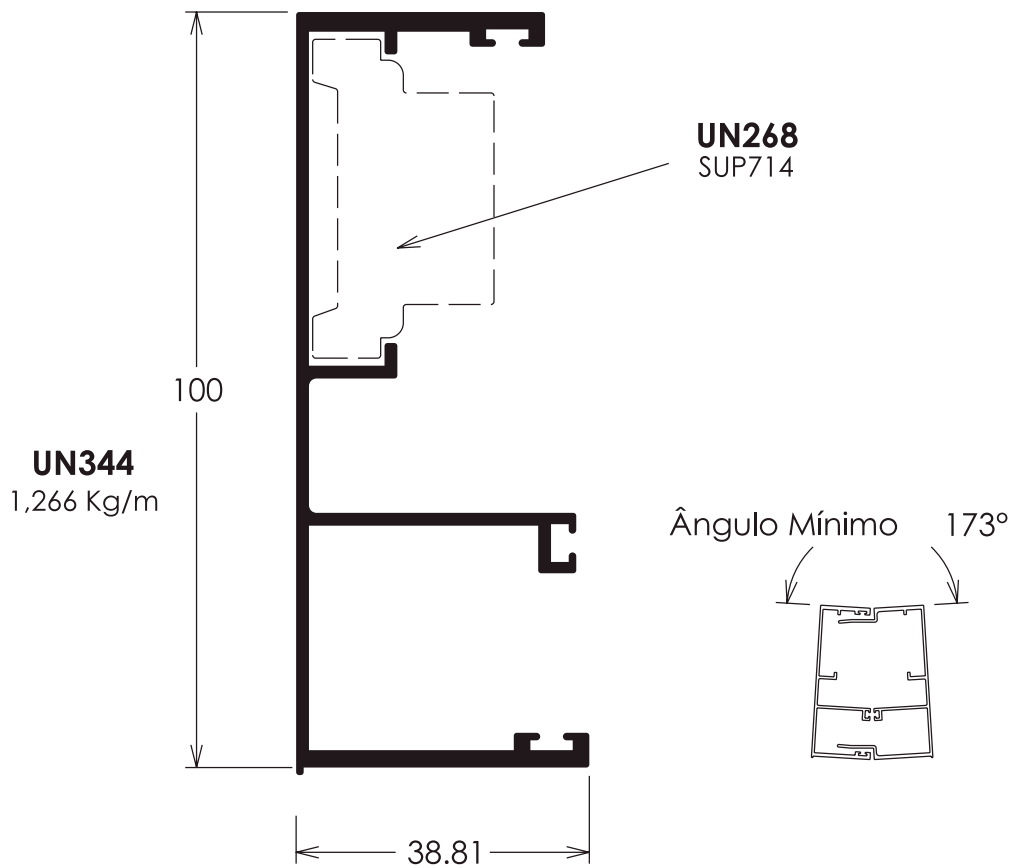
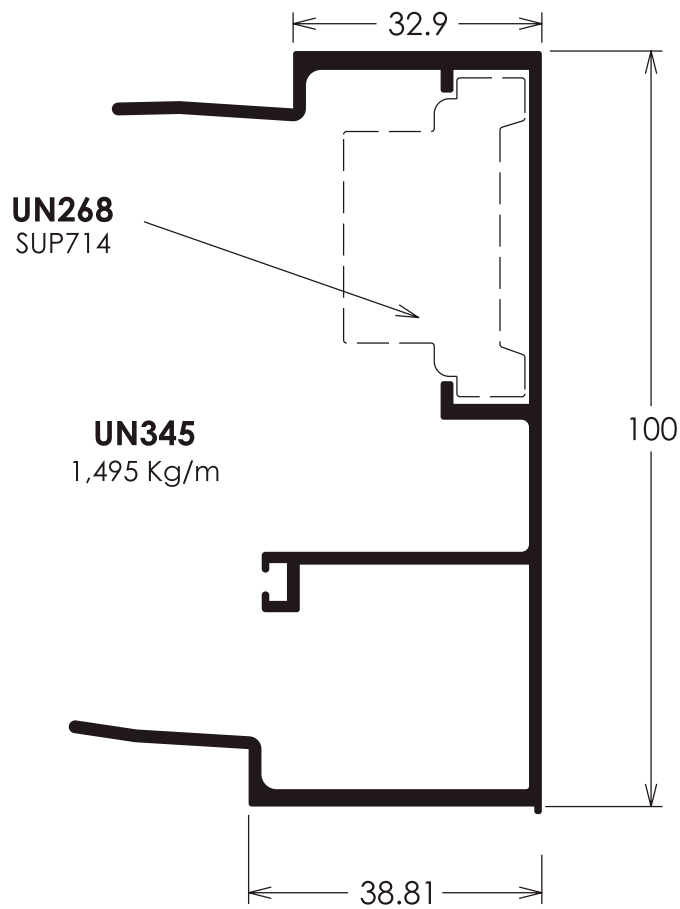

Módulo Fachada 127

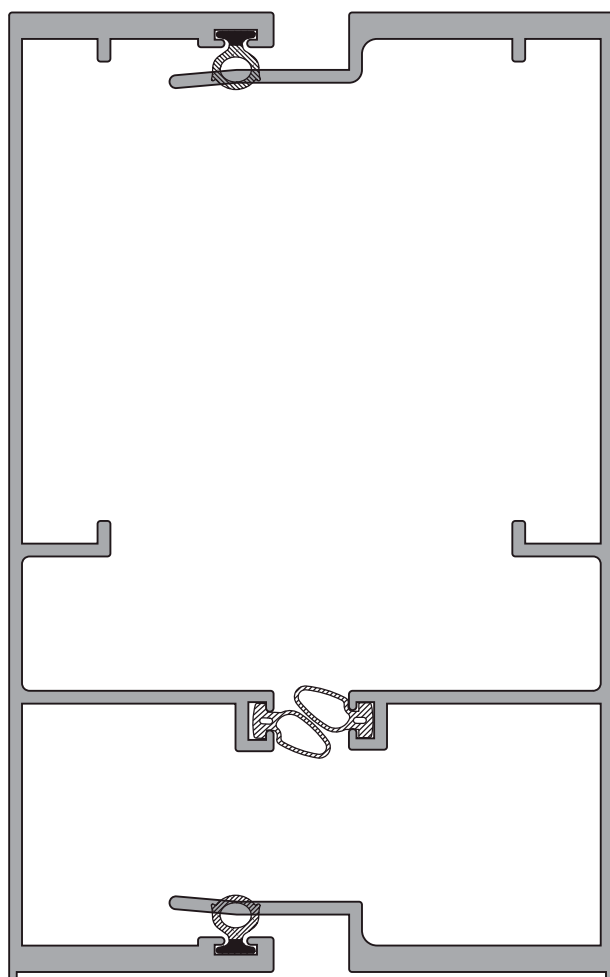

Perfis Fachada 100

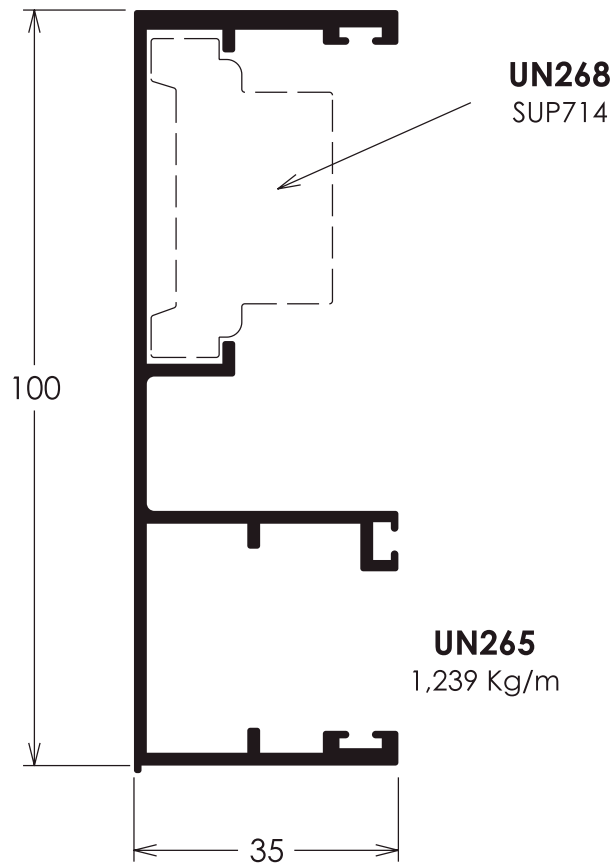
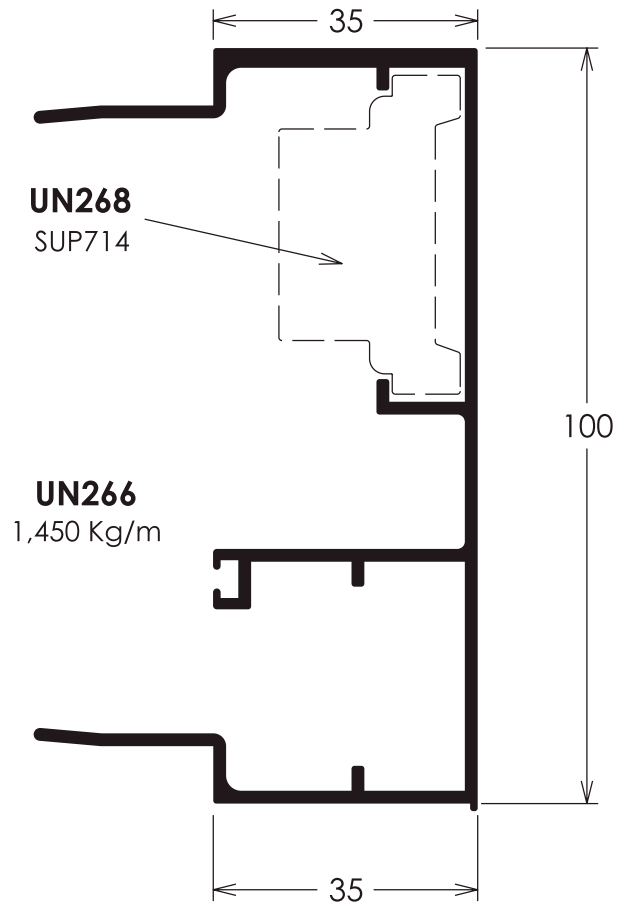

Montagem Fachada 127

UNIT MÓDULO 127 - FACHADA

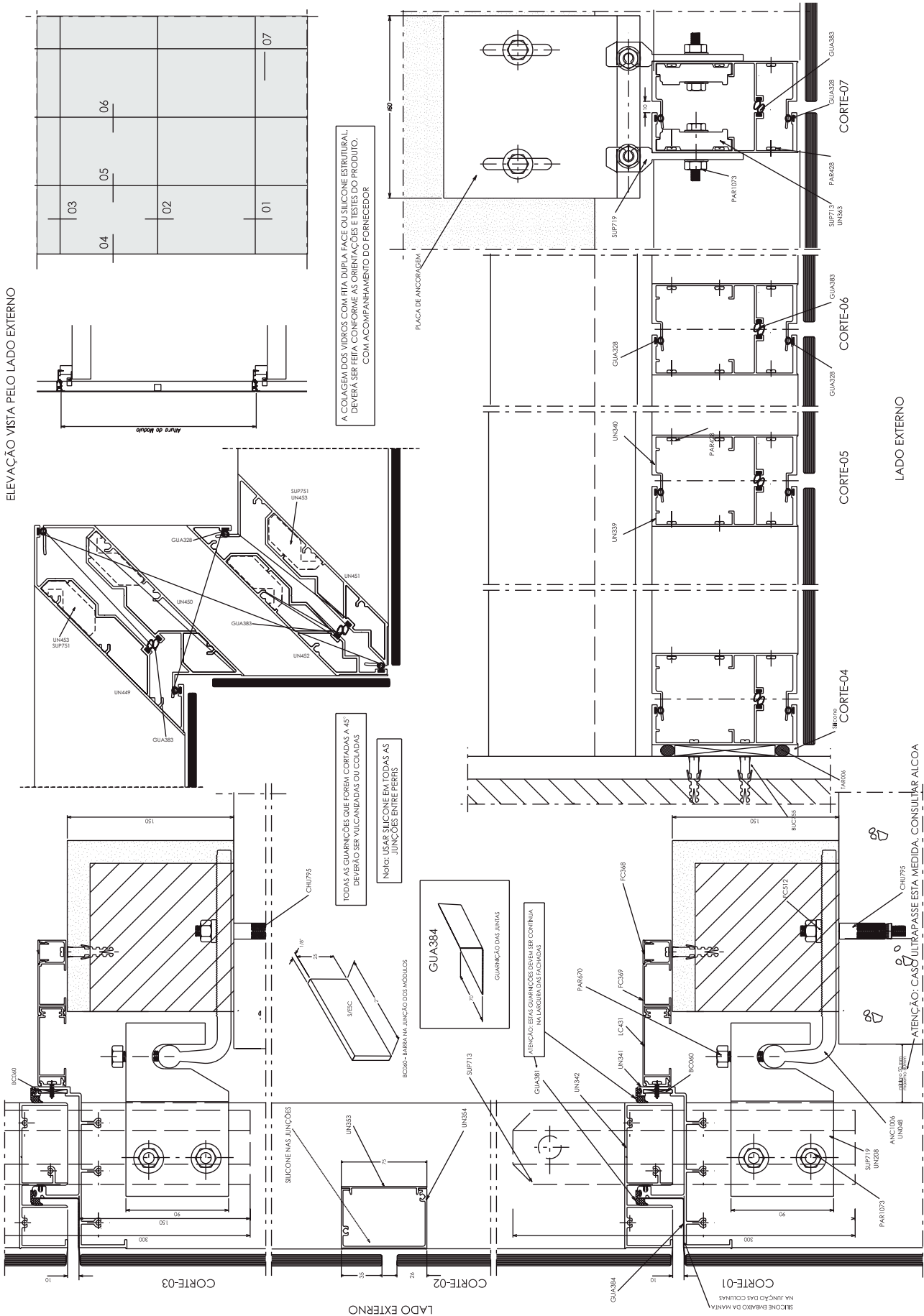

Montagem Fachada 127

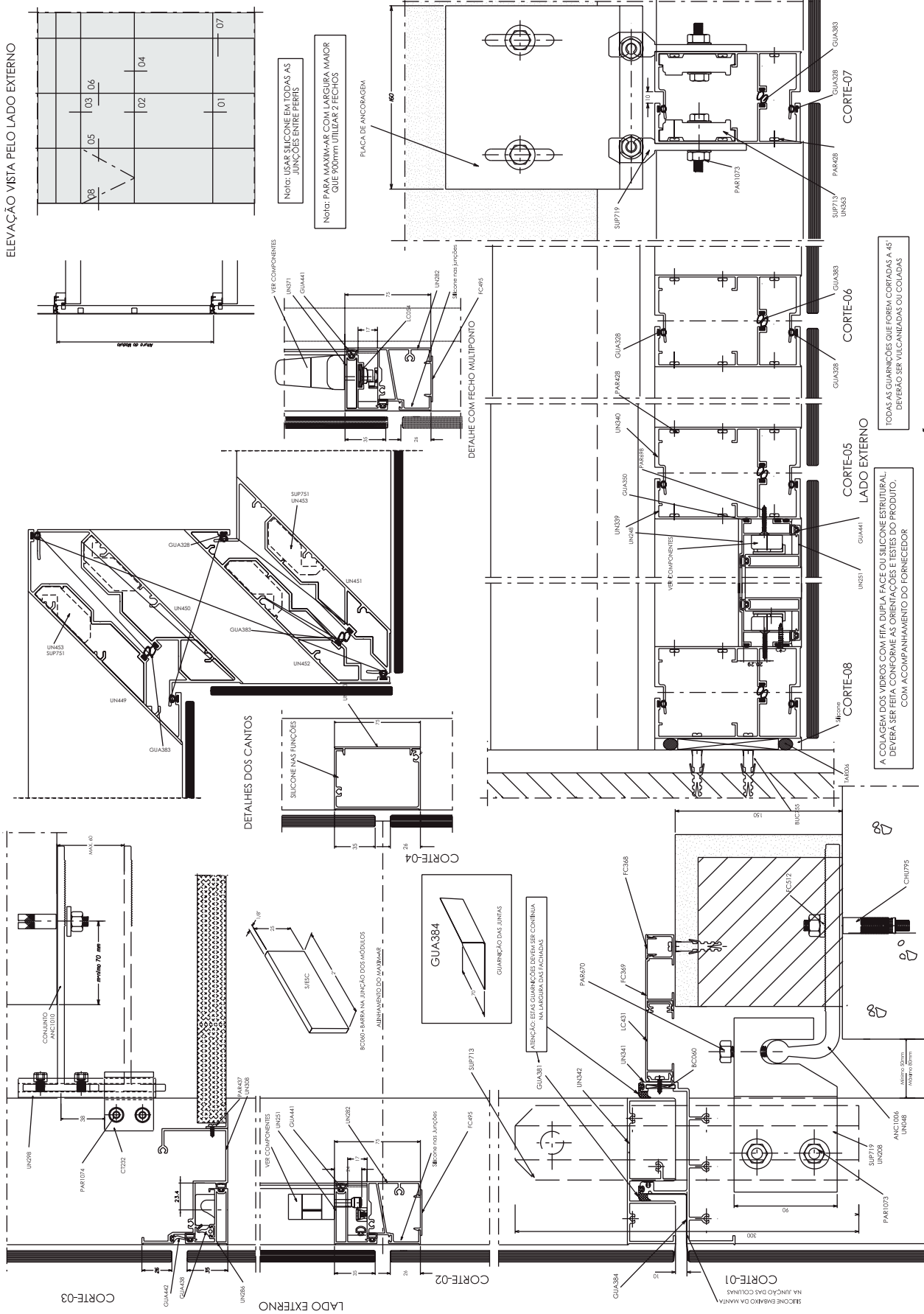

UNIT MÓDULO 127 - FACHADA MAX FECHO SIMPLES E MULTIPONTO

Montagem Fachada 127

UNIT MÓDULO 127 - FACHADA MAX - FECHO PERIMETRAL



Diagrama de Dimensões

UNIT - Módulo Fachada 127 auxiliar

Liga 6060 T5
Liga 6351 T6

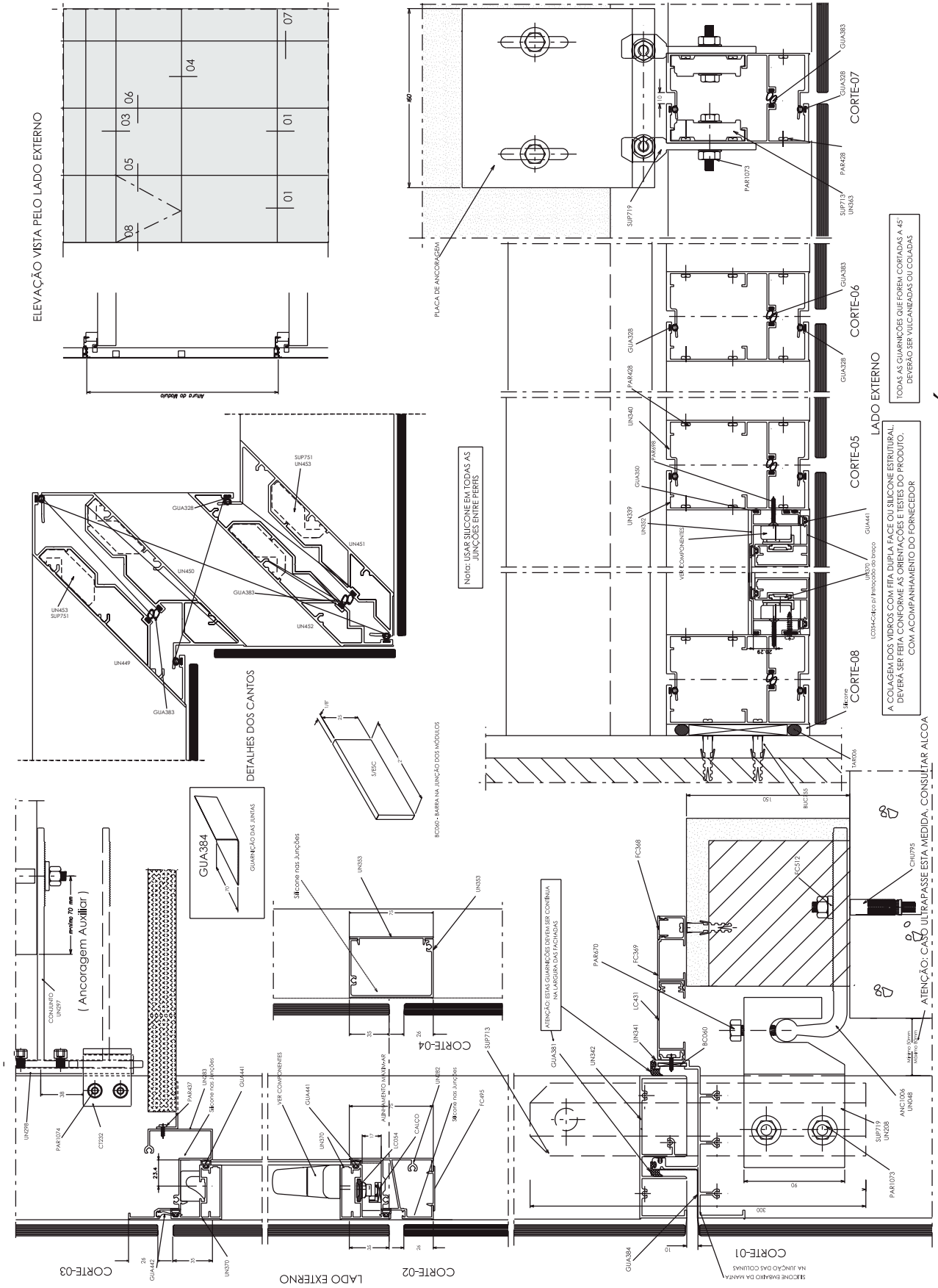
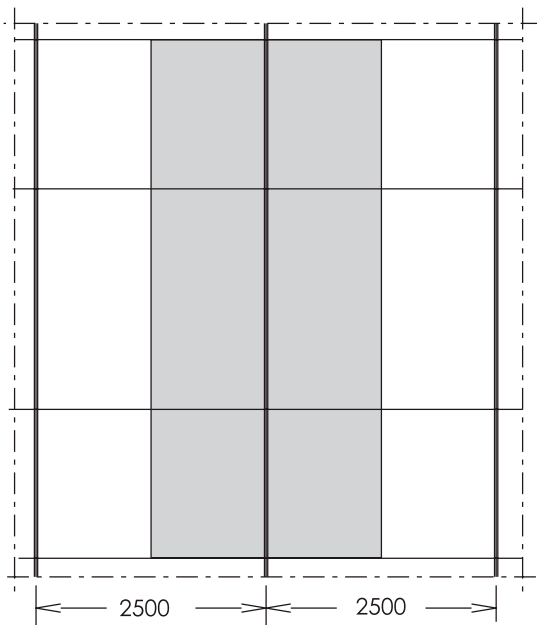

Pressão de ensaio
Flecha adm = 15.2 mm (H/175)

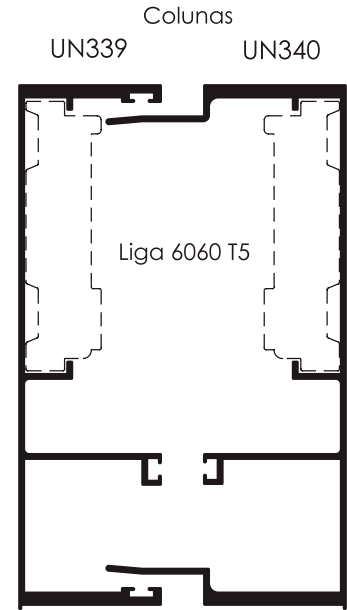
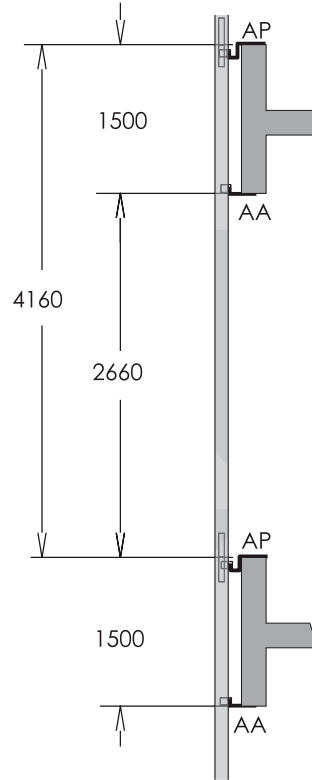

Área = 1207 mm²
Jx = 2811890 mm⁴
Wx = 42044 mm³
H = 137,8 mm

Liga 6060 T5
Tensão adm = 7 kg/mm²

Ancoragem principal (AP) e auxiliar(AA)

Coluna contínua 2 pavimentos

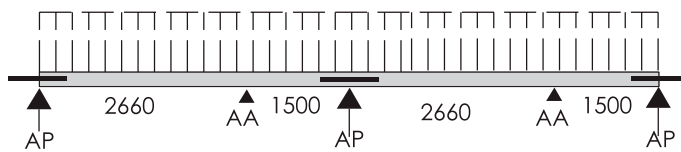

Importante: Consultar o fabricante do vidro para determinar a espessura em função da pressão de segurança

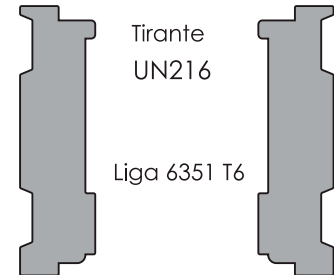

Área = 1932 mm²
Jx = 633372 mm⁴
Wx = 18895 mm³
H = 67 mm

Liga 6351 T6
Tensão adm = 15 kg/mm²

Conclusão: Pela norma NBR 10821- 2011 Revisada, o conjunto (coluna-luva) com ancoragens principais e auxiliares, atende:

Pressão de ensaio máxima = 1850 Pa

Pressão de segurança = 2770 Pa

Condição de utilização: 30 pavimentos ou 90 m na região V

Perfis Fachada 127

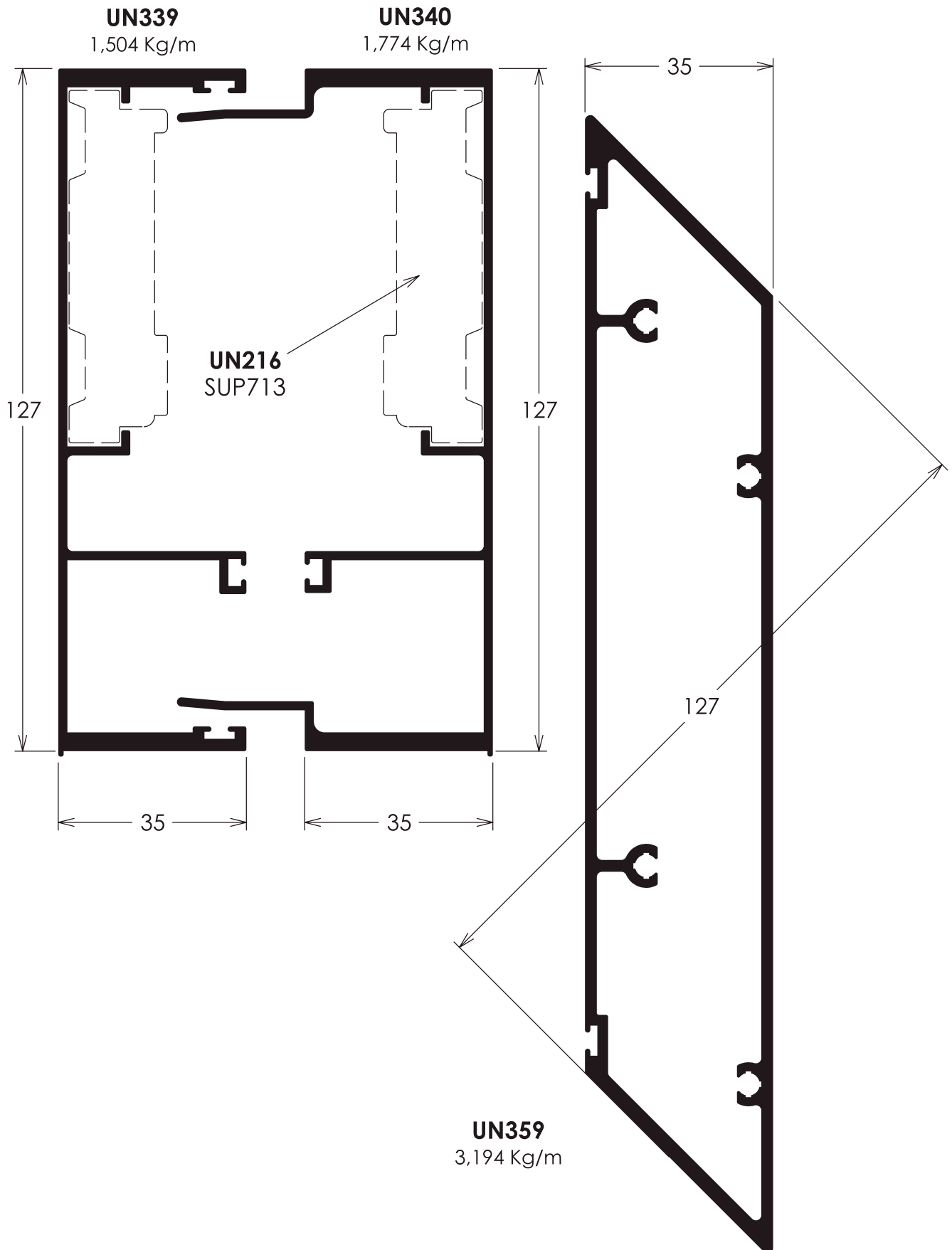

Perfis Fachada 127

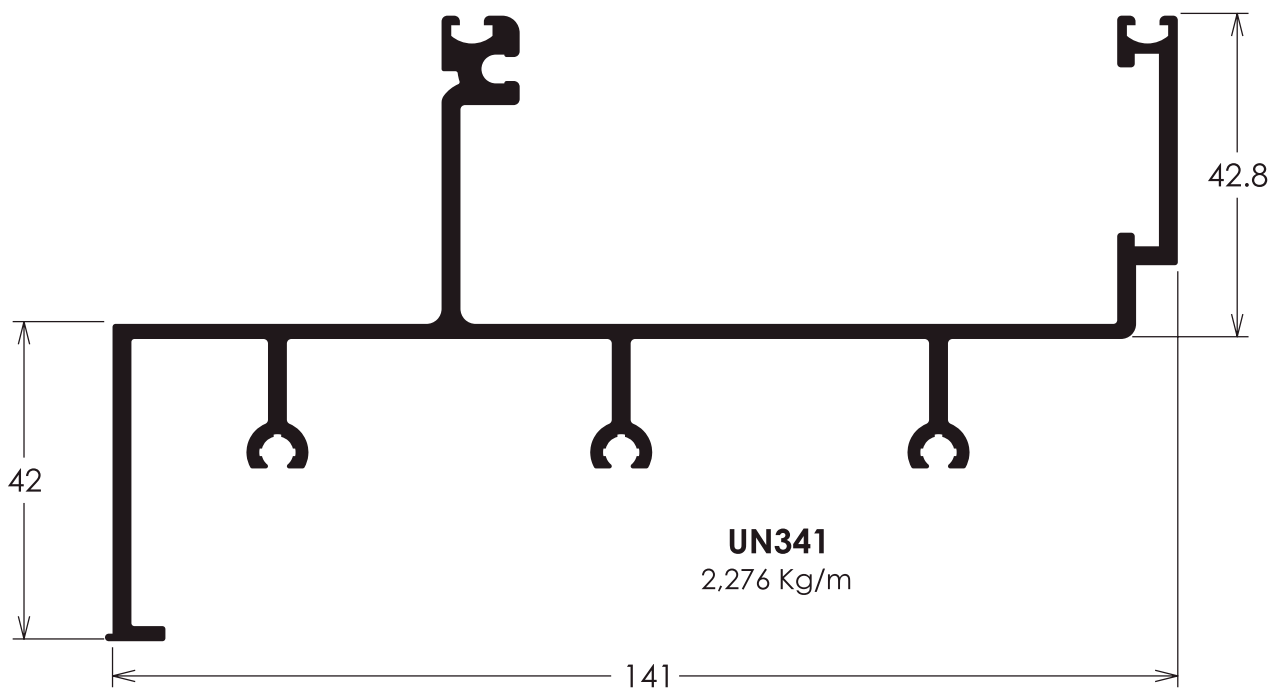
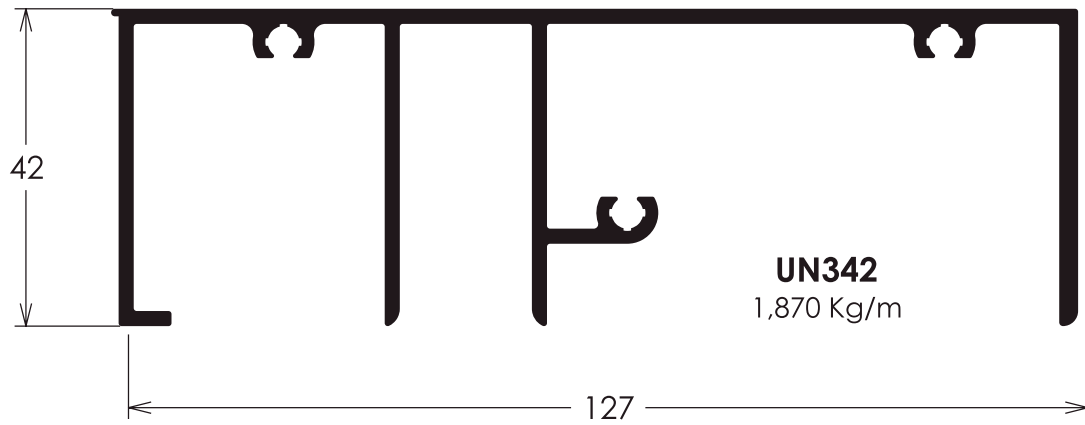

Perfis Fachada 127

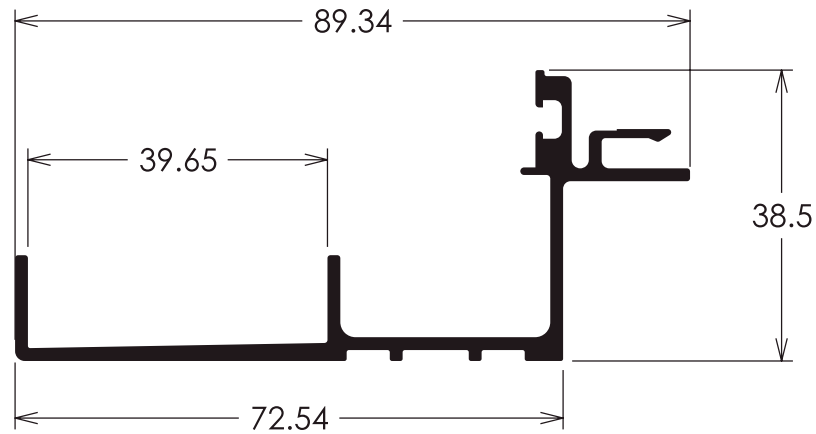
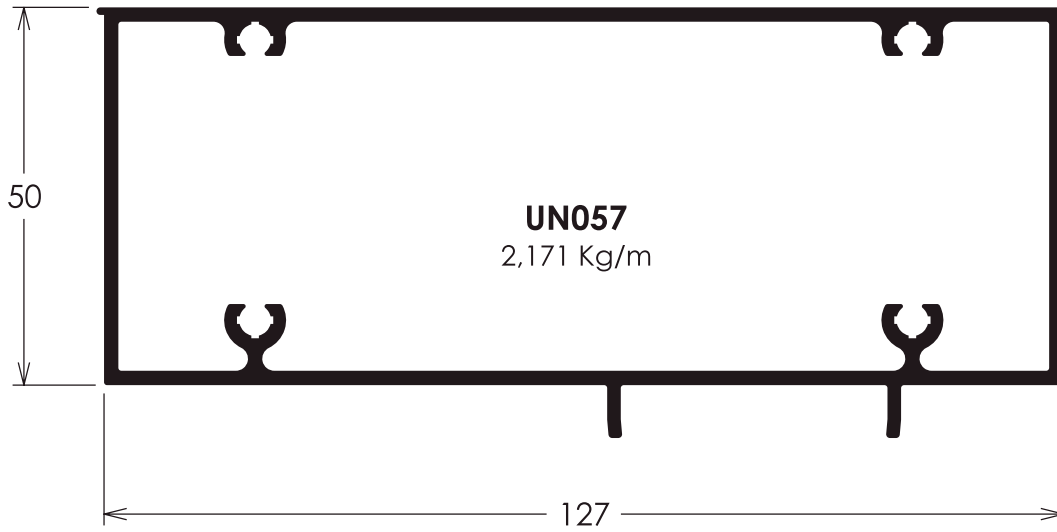

UN002
0,887 Kg/m

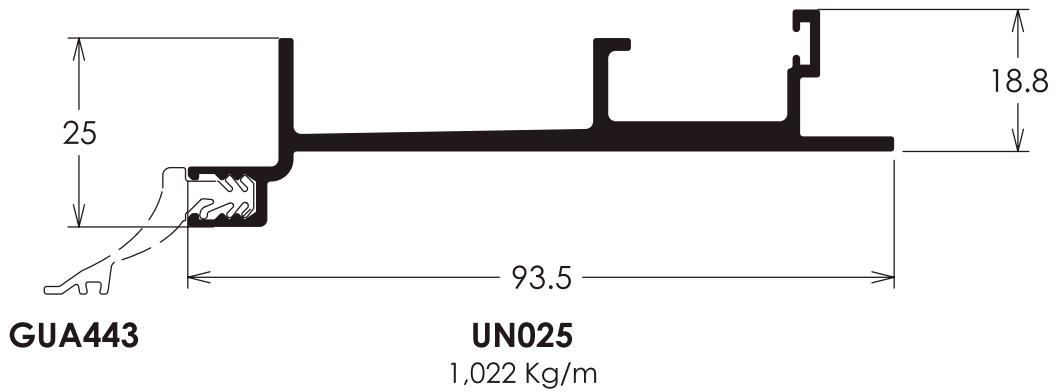

Perfis Fachada 127

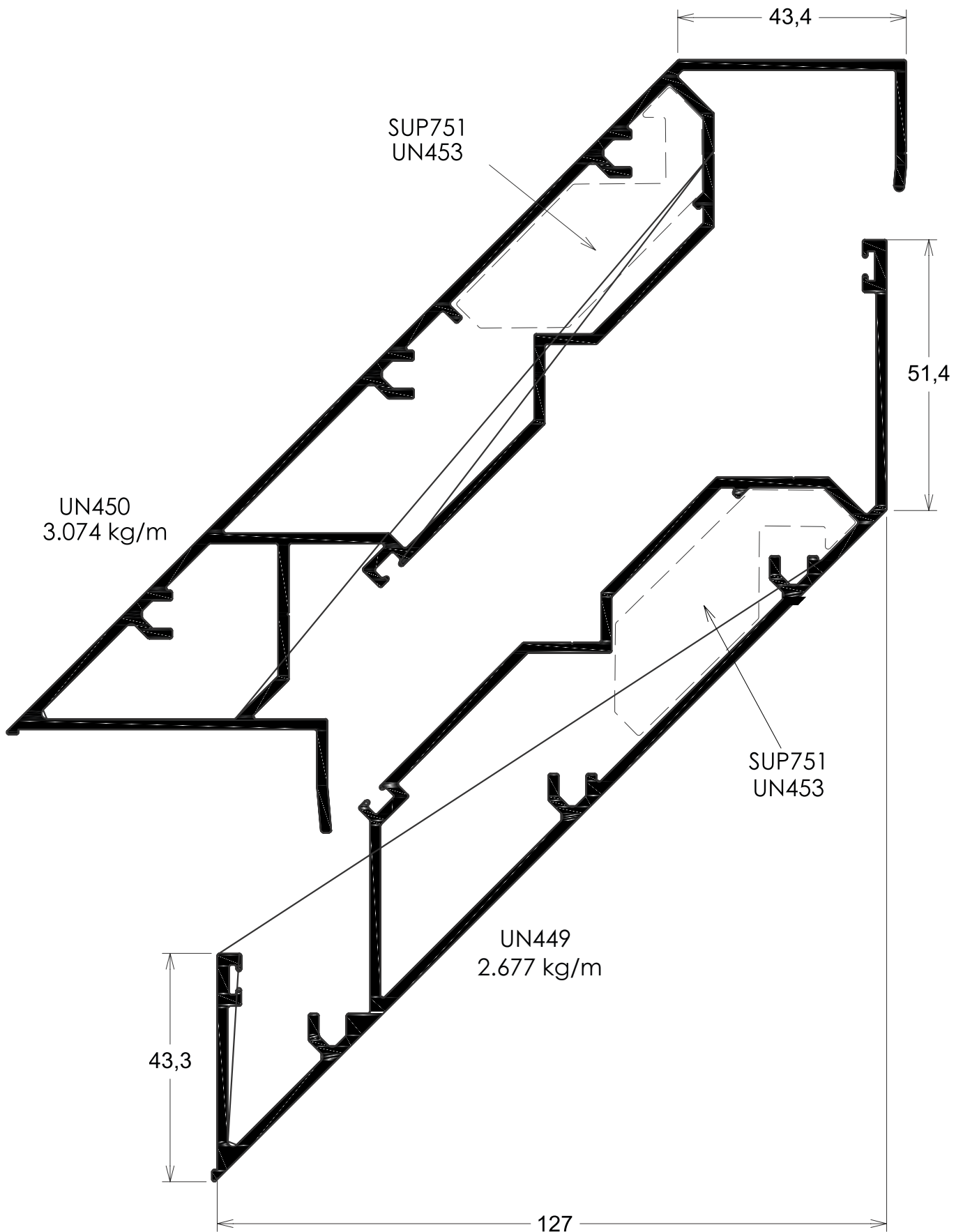

Perfis Fachada 127

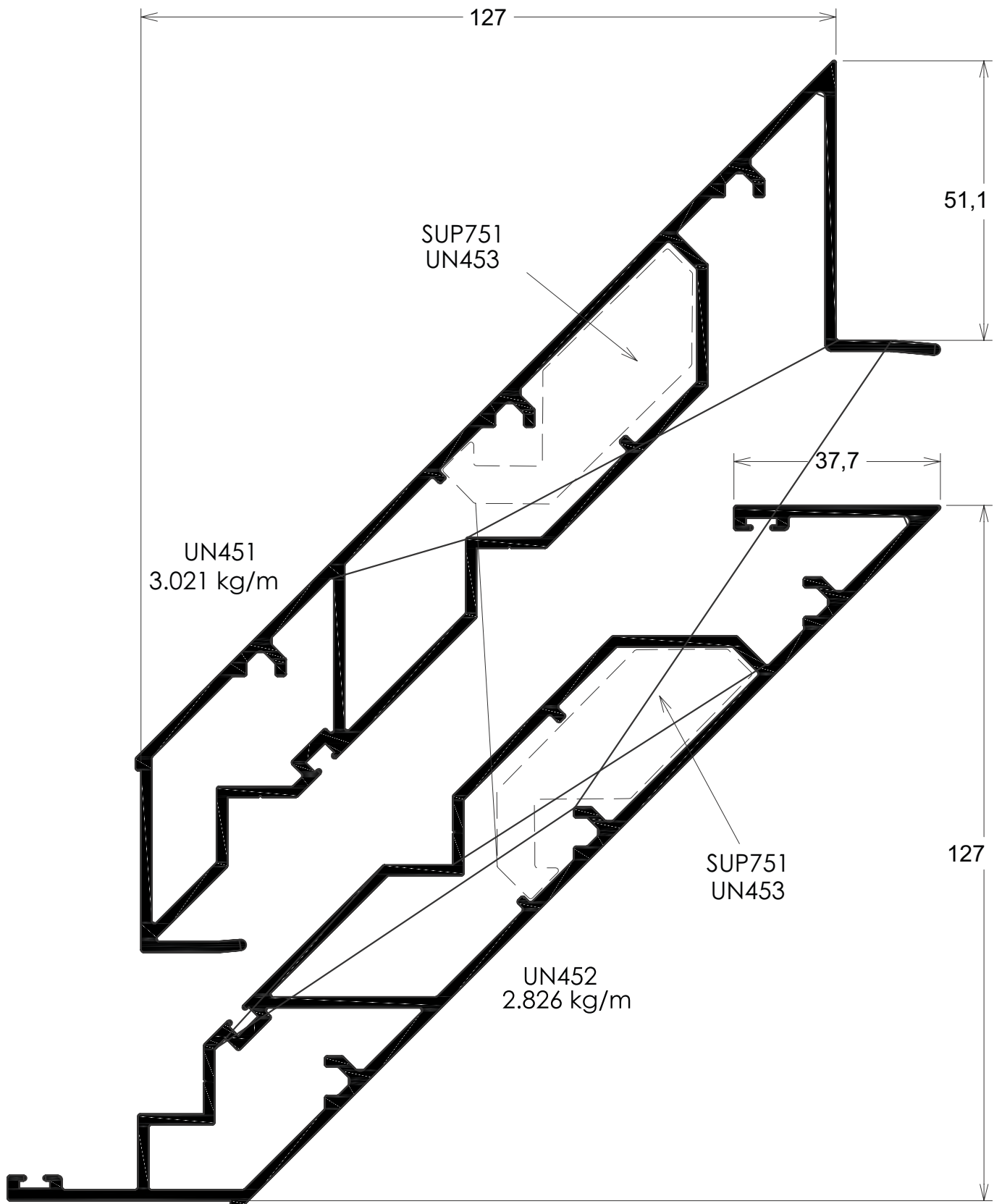

Módulo Anc. Telescópica

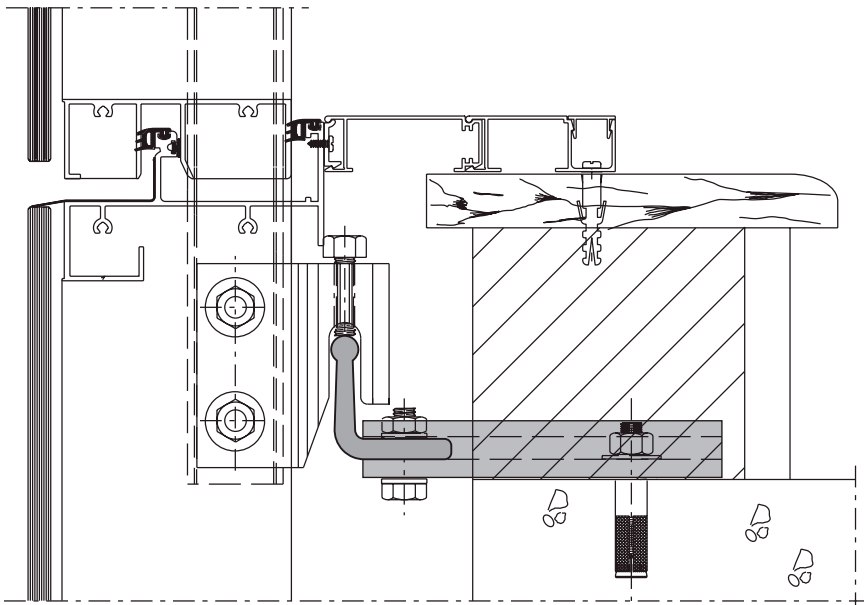

Montagem Anc. Telescópica

ELEVAÇÃO VISTA PELO LADO EXTERNO

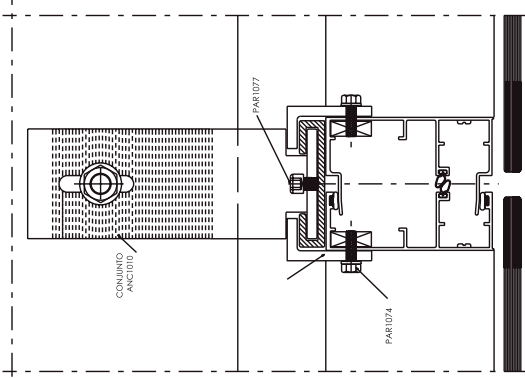
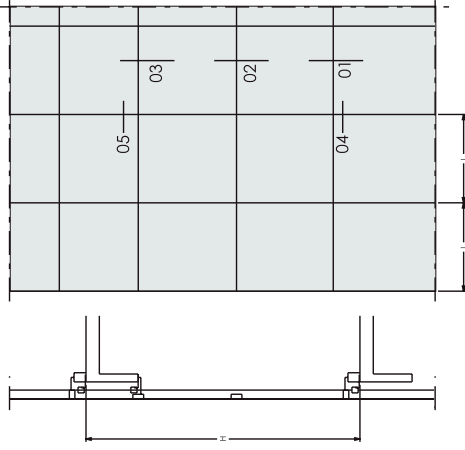

CORTE-05

A COLAGEM DOS VIDROS COM FITA D'EPILA FACE OU SILICONE ESTRUTURAL, DEVERÁ SER FEITA CONFORME AS ORIENTAÇÕES E TESTES DO PRODUTO, COM ACOMPANHAMENTO DO FORNECEDOR

TODAS AS GUARNIÇÕES QUE FOREM CORFADAS A 45° DEVERÃO SER VULCANIZADAS OU COLADAS

NOTA: USAR SILICONE EM TODAS AS JUNÇÕES ENTRE PERFIS

ATENÇÃO: PROJETO APENAS ILUSTRATIVO PARA APLICAÇÃO DA ANCORAGEM TELESCÓPICAS

ATENÇÃO: PARA UTILIZAÇÃO OU NÃO DA ANCORAGEM AUXILIAR VERIFICAR OS GRÁFICOS NOS CATÁLOGOS DE CADA SISTEMA DE FACHADA

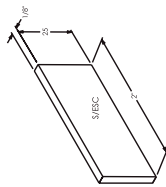

BICO - BARRA NA JUNÇÃO DOS MÓDULOS

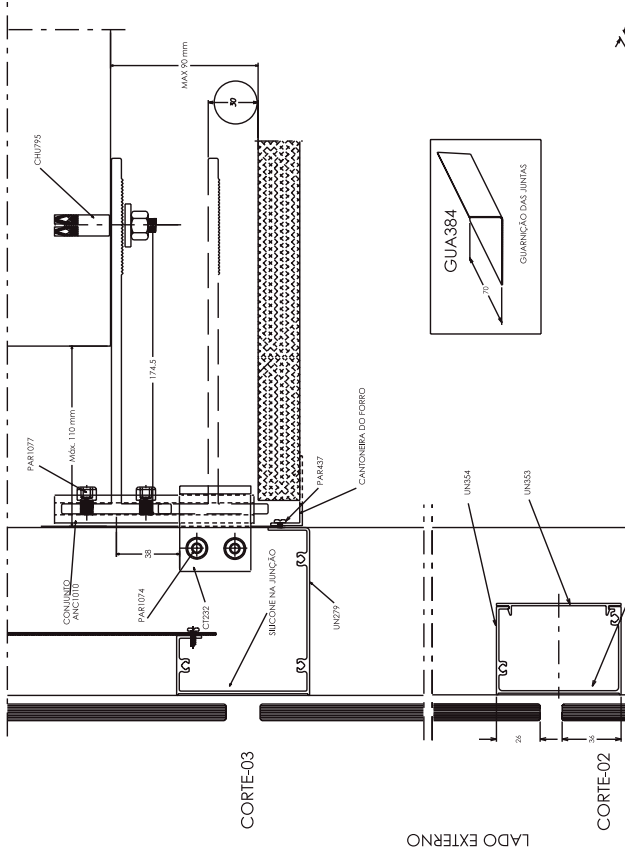

CORTE-03

CORTE-02

LADO EXTERNO

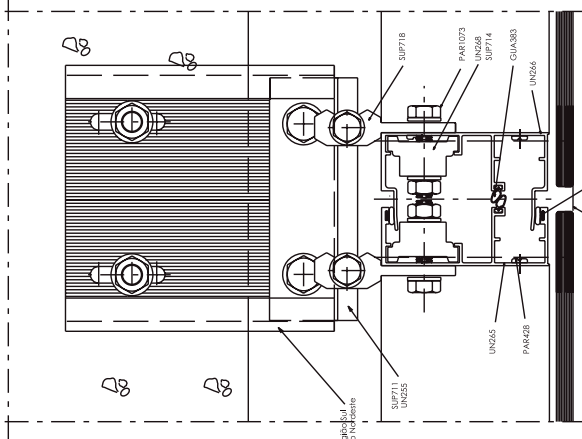

CORTE-04

LADO EXTERNO

UNIT MÓDULO 100-ANCORAGEM TELESCÓPICA

Diagrama de Dimensões

Unit - Ancoragem Telescópica

Ancoragem Principal UN254

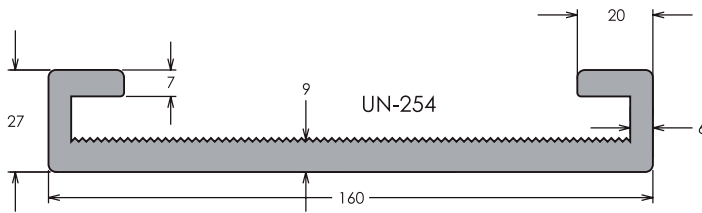
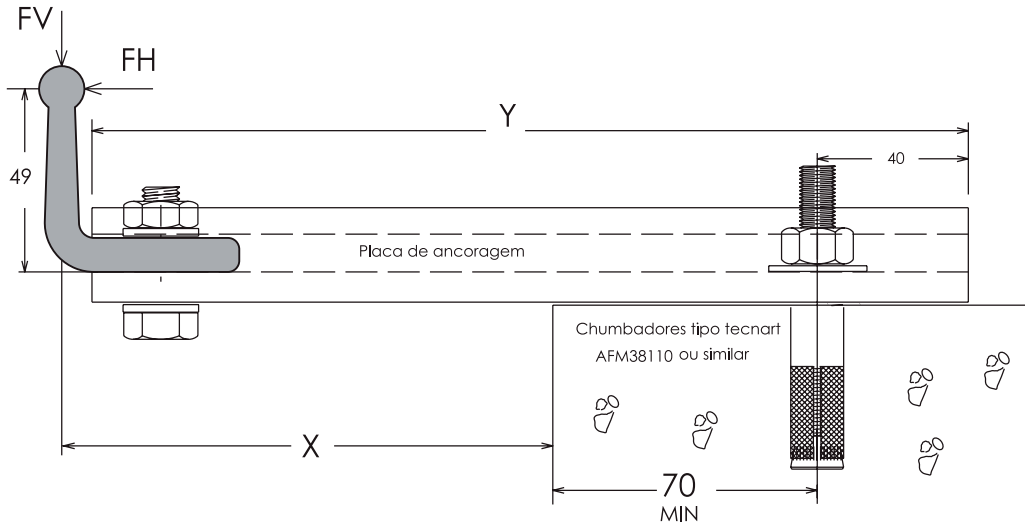

Área = 1772 mm²
 Jx = 100808 mm⁴
 Wx = 5311 mm³
 Peso = 4.8 kg/m

Peso do vidro = 25 kg/m² (10 mm)
 Peso do caixilho = 10 kg/m²
 PV = 35 kg/m²

6351 T6 Lr = 29 kg/mm² Le = 25.5 kg/mm²

Só ancoragens principais
 Pé Direito = 3200 mm

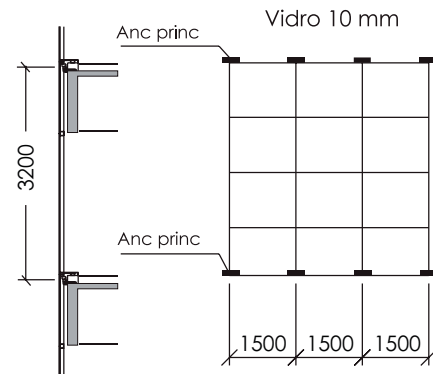

TENSÃO ADMISSÍVEL = 15 kg/mm² (P. ENSAIO)

P ENSAIO (Pa)	P DISTR (kg/m)	FH (kg)	FV (kg)	T MAX (kg/mm ²) PLACA	T MAX (kg/mm ²) CANTONEIRA	FLECHA (mm)	X MAX (mm)	Y (mm)
800	120	384	168	8.6	9.7	0.9	140	242
1000	150	480	168	9.2	12.1	1	140	242
1200	180	576	168	10.2	14.5	1.2	140	242

TENSÃO LIMITE = 22.5 kg/mm² (P. SEGURANCA)

P SEGUR (Pa)	P DISTR (kg/m)	FH (kg)	FV (kg)	T MAX (kg/mm ²) PLACA	T MAX (kg/mm ²) CANTONEIRA	FLECHA (mm)	X MAX (mm)	Y (mm)
1200	180	576	168	10.2	14.5	1.2	140	242
1500	225	720	168	11.6	18	1.5	140	242
1800	270	864	168	13.1	21.7	1.7	140	242

Diagrama de Dimensões

Unit - Ancoragem Telescópica

Ancoragem Principal UN254

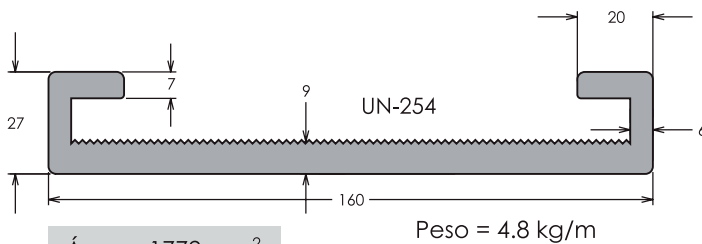
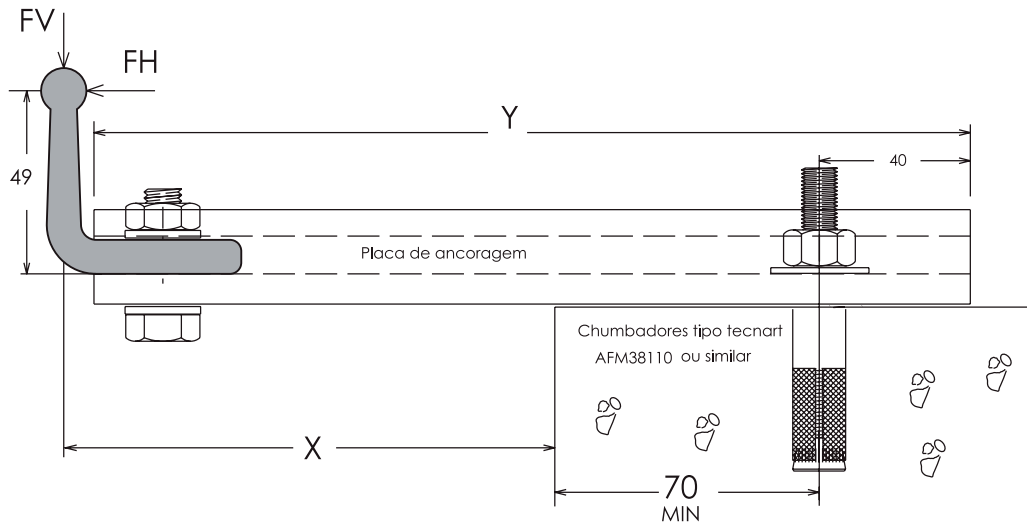

Área = 1772 mm²
 Jx = 100808 mm⁴
 Wx = 5311 mm³

Peso = 4.8 kg/m

Peso do vidro = 25 kg/m² (10 mm)
 Peso do caixilho = 10 kg/m²
 PV = 35 kg/m²

6351 T6 Lr = 29 kg/mm² Le = 25.5 kg/mm²

Ancoragens principais e auxiliares
 Pé Direito = 3200 mm

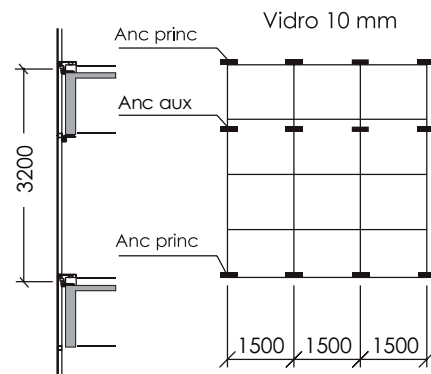

TENSÃO ADMISSÍVEL = 15 kg/mm² (P. ENSAIO)

P ENSAIO (Pa)	P DISTR (kg/m)	FH (kg)	FV (kg)	T MAX (kg/mm ²) PLACA	T MAX (kg/mm ²) CANTONEIRA	FLECHA (mm)	X MAX (mm)	Y (mm)
800	120	192	168	6.3	4.9	0.64	140	242
1000	150	240	168	6.8	6.1	0.71	140	242
1200	180	288	168	7.3	7.3	0.8	140	242
1500	225	360	168	8	9.1	0.9	140	242
1800	270	432	168	8.7	10.9	1.0	140	242

TENSÃO LIMITE = 22.5 kg/mm² (P. SEGURANCA)

P SEGUR (Pa)	P DISTR (kg/m)	FH (kg)	FV (kg)	T MAX (kg/mm ²) PLACA	T MAX (kg/mm ²) CANTONEIRA	FLECHA (mm)	X MAX (mm)	Y (mm)
1200	180	288	168	7.3	7.3	0.8	140	242
1500	225	360	168	8	9.1	0.9	140	242
1800	270	432	168	8.7	10.9	1.0	140	242
2250	338	541	168	9.8	13.6	1.2	140	242
2700	405	648	168	10.9	16.3	1.4	140	242

Diagrama de Dimensões

Unit - Ancoragem Telescópica

Ancoragem Principal UN254

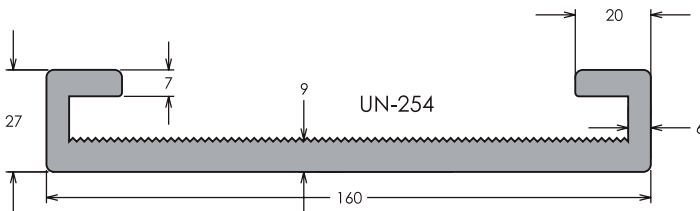
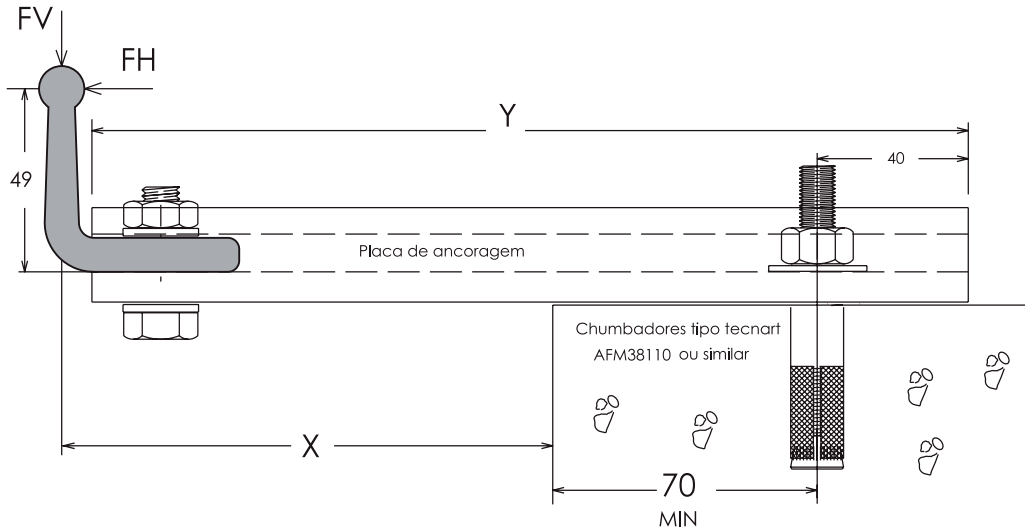

Área = 1772 mm²
 Jx = 100808 mm⁴
 Wx = 5311 mm³

Peso = 4.8 kg/m

Peso do vidro = 25 kg/m² (10 mm)
 Peso do caixilho = 10 kg/m²
 PV = 35 kg/m²

6351 T6 Lr = 29 kg/mm² Le = 25.5 kg/mm²

Só ancoragens principais
 Pé Direito = 4200 mm

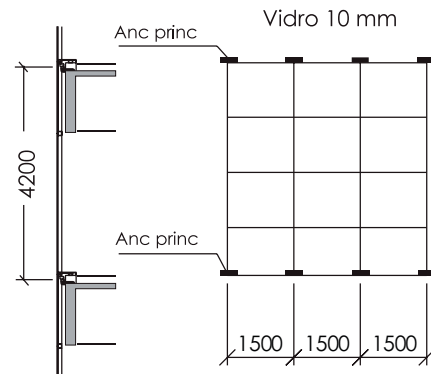

TENSÃO ADMISSÍVEL = 15 kg/mm² (P. ENSAIO)

P ENSAIO (Pa)	P DISTR (kg/m)	FH (kg)	FV (kg)	T MAX (kg/mm ²) PLACA	T MAX (kg/mm ²) CANTONEIRA	FLECHA (mm)	X MAX (mm)	Y (mm)
800	120	504	221	10.8	12.7	1.2	140	242
1000	150	630	221	12.1	15.8	1.4	140	242

TENSÃO LIMITE = 22.5 kg/mm² (P. SEGURANCA)

P SEGUR (Pa)	P DISTR (kg/m)	FH (kg)	FV (kg)	T MAX (kg/mm ²) PLACA	T MAX (kg/mm ²) CANTONEIRA	FLECHA (mm)	X MAX (mm)	Y (mm)
1200	180	756	221	13.4	19	1.6	140	242
1500	225	945	221	15.4	23.8	1.9	140	242

Diagrama de Dimensões

Unit - Ancoragem Telescópica

Ancoragem Principal UN256

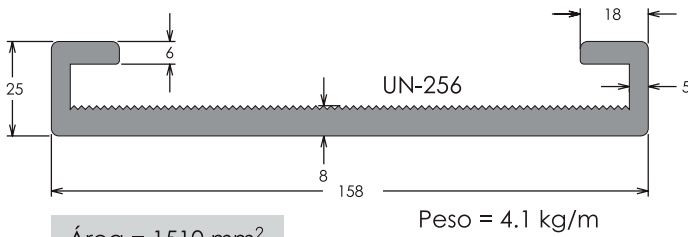
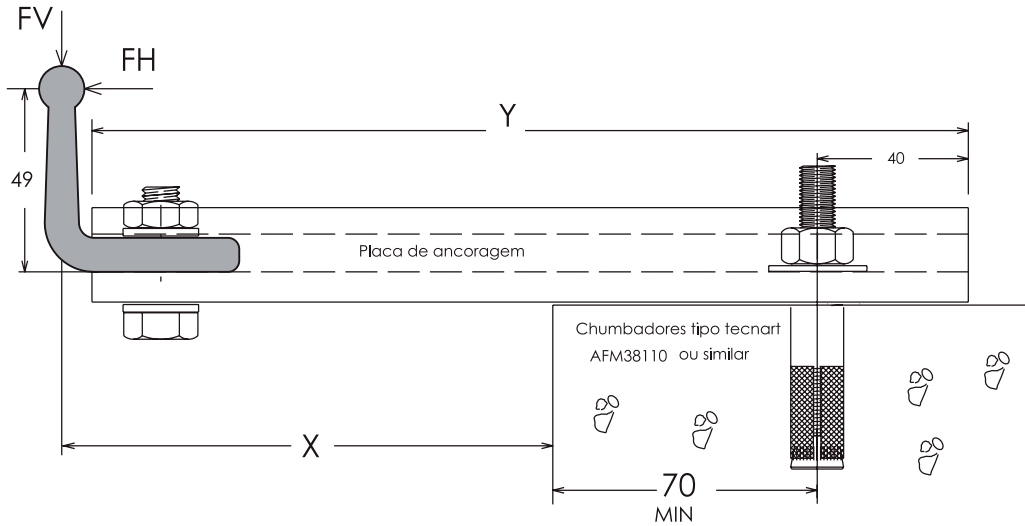

Área = 1510 mm²
 Jx = 71451 mm⁴
 Wx = 3976 mm³

Peso = 4.1 kg/m

6351 T6 Lr = 29 kg/mm² Le = 25.5 kg/mm²

Peso do vidro = 25 kg/m² (10 mm)
 Peso do caixilho = 10 kg/m²
 PV = 35 kg/m²

Só ancoragens principais
 Pé Direito = 3200 mm

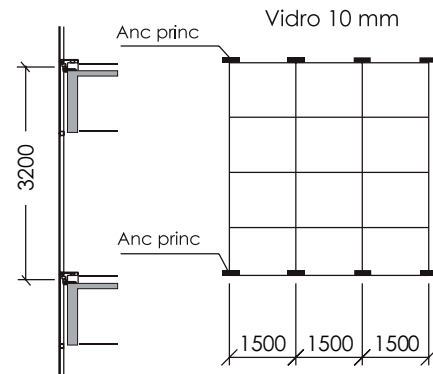

TENSÃO ADMISSÍVEL = 15 kg/mm² (P. ENSAIO)

P ENSAIO (Pa)	P DISTR (kg/m)	FH (kg)	FV (kg)	T MAX (kg/mm ²) PLACA	T MAX (kg/mm ²) CANTONEIRA	FLECHA (mm)	X MAX (mm)	Y (mm)
800	120	384	168	11	9.7	1.25	140	242
1000	150	480	168	12.3	12.3	1.44	140	242
1200	180	576	168	13.6	14.5	1.62	140	242

TENSÃO LIMITE = 22.5 kg/mm² (P. SEGURANCA)

P SEGUR (Pa)	P DISTR (kg/m)	FH (kg)	FV (kg)	T MAX (kg/mm ²) PLACA	T MAX (kg/mm ²) CANTONEIRA	FLECHA (mm)	X MAX (mm)	Y (mm)
1200	180	576	168	13.6	14.5	1.62	140	242
1500	225	720	168	15.5	18	1.9	140	242
1800	270	864	168	17.4	21.7	2.2	140	242

Diagrama de Dimensões

Unit - Ancoragem Telescópica

Ancoragem Principal UN256

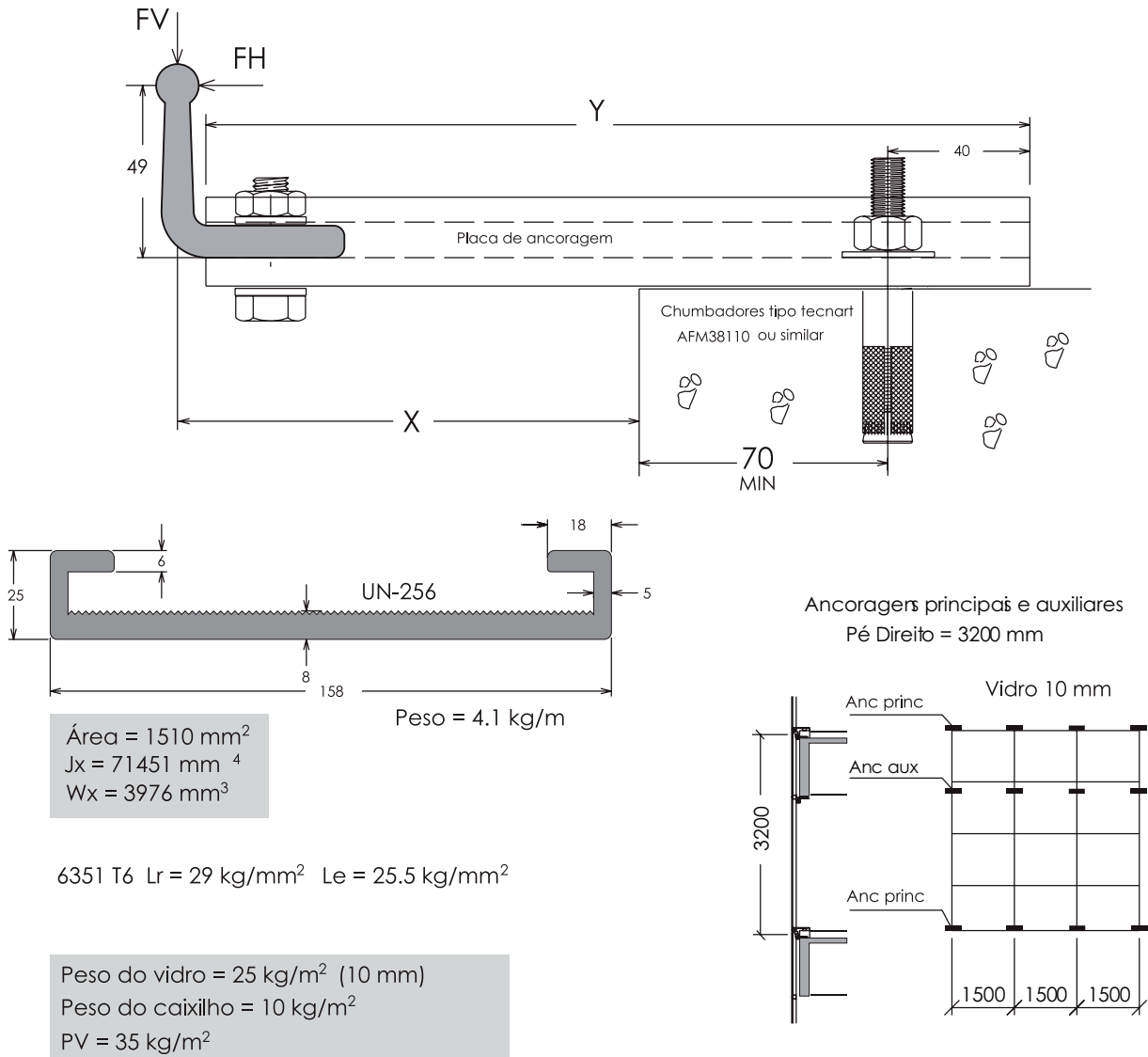

TENSÃO ADMISSÍVEL = 15 kg/mm² (P. ENSAIO)

P ENSAIO (Pa)	P DISTR (kg/m)	FH (kg)	FV (kg)	T MAX (kg/mm ²) PLACA	T MAX (kg/mm ²) CANTONEIRA	FLECHA (mm)	X MAX (mm)	Y (mm)
800	120	192	168	8.5	4.9	0.87	140	242
1000	150	240	168	9.1	6.1	0.97	140	242
1200	180	288	168	9.7	7.3	1.1	140	242
1500	225	360	168	10.7	9.1	1.2	140	242
1800	270	432	168	11.7	10.9	1.3	140	242

TENSÃO LIMITE = 22.5 kg/mm² (P. SEGURANCA)

P SEGUR (Pa)	P DISTR (kg/m)	FH (kg)	FV (kg)	T MAX (kg/mm ²) PLACA	T MAX (kg/mm ²) CANTONEIRA	FLECHA (mm)	X MAX (mm)	Y (mm)
1200	180	288	168	9.7	7.3	1.1	140	242
1500	225	360	168	10.7	9.1	1.2	140	242
1800	270	432	168	11.7	10.9	1.3	140	242
2250	338	541	168	13.1	13.6	1.5	140	242
2700	405	648	168	14.5	16.3	1.7	140	242

Diagrama de Dimensões

Unit - Ancoragem Telescópica

Ancoragem Principal UN256

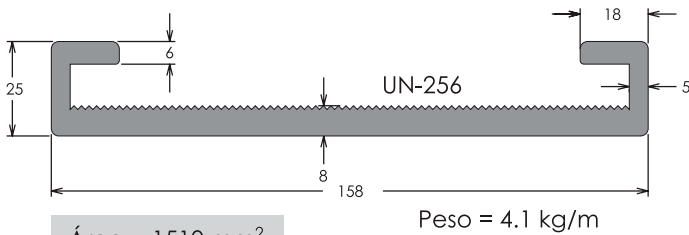
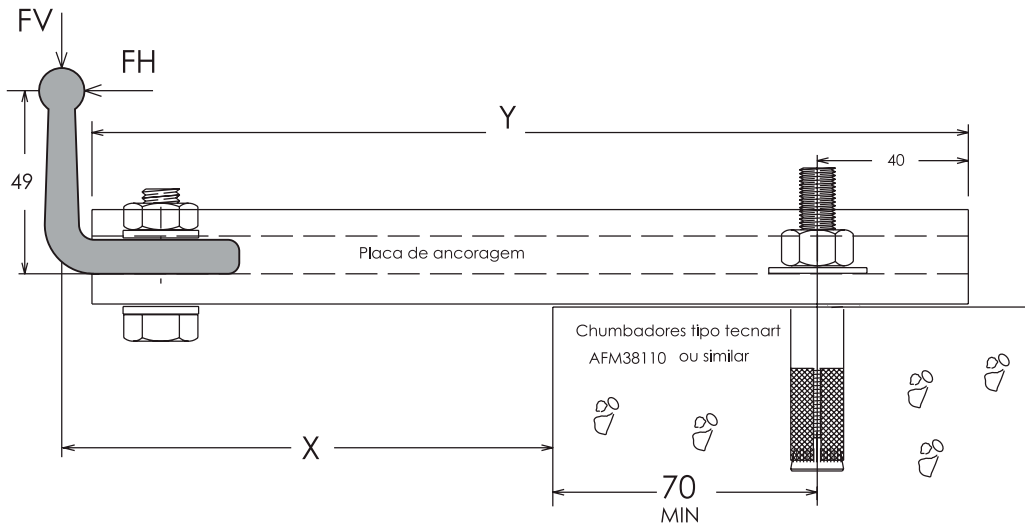

Área = 1510 mm²
 Jx = 71451 mm⁴
 Wx = 3976 mm³

6351 T6 Lr = 29 kg/mm² Le = 25.5 kg/mm²

Peso do vidro = 25 kg/m² (10 mm)
 Peso do caixilho = 10 kg/m²
 PV = 35 kg/m²

Só ancoragens principais
 Pé Direito = 4200 mm

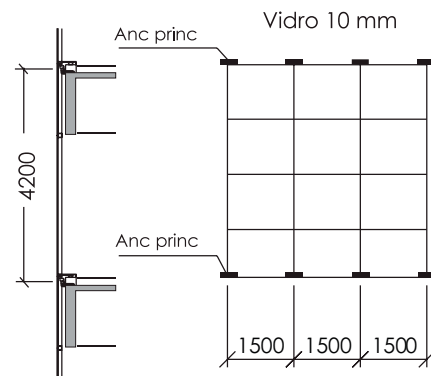

TENSÃO ADMISSÍVEL = 15 kg/mm² (P. ENSAIO)

P ENSAIO (Pa)	P DISTR (kg/m)	FH (kg)	FV (kg)	T MAX (kg/mm ²) PLACA	T MAX (kg/mm ²) CANTONEIRA	FLECHA (mm)	X MAX (mm)	Y (mm)
800	120	504	221	14.5	12.7	1.6	140	242
1000	150	630	221	15.6	15.8	1.7	130	232

TENSÃO LIMITE = 22.5 kg/mm² (P. SEGURANCA)

P SEGUR (Pa)	P DISTR (kg/m)	FH (kg)	FV (kg)	T MAX (kg/mm ²) PLACA	T MAX (kg/mm ²) CANTONEIRA	FLECHA (mm)	X MAX (mm)	Y (mm)
1200	180	756	221	17.8	19	2.1	140	242
1500	225	945	221	20.3	23.8	2.4	130	232

Diagrama de Dimensões

Unit - Ancoragem Telescópica

Ancoragem Principal UN256

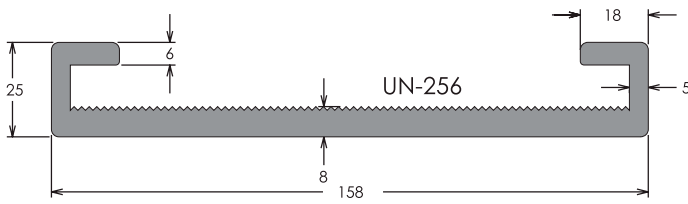
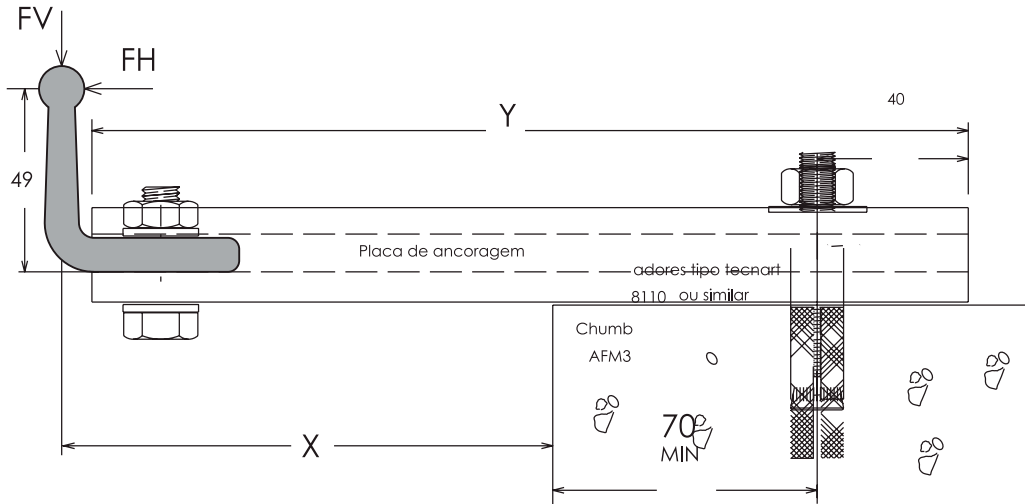

Área = 1510 mm²
 Jx = 71451 mm⁴
 Wx = 3976 mm³

Peso = 4.1 kg/m

6351 T6 Lr = 29 kg/mm² Le = 25.5 kg/mm²

Peso do vidro = 25 kg/m² (10 mm)
 Peso do caixilho = 10 kg/m²
 PV = 35 kg/m²

Ancoragens principais e auxiliares
 Pé Direito = 4200 mm

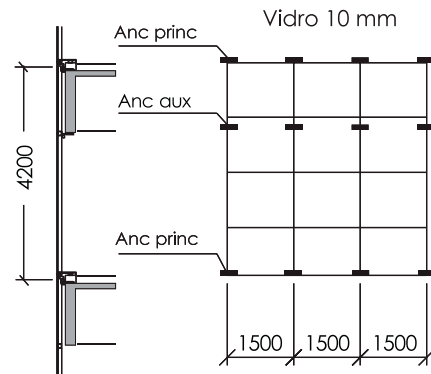

TENSÃO ADMISSÍVEL = 15 kg/mm² (P. ENSAIO)

P ENSAIO (Pa)	P DISTR (kg/m)	FH (kg)	FV (kg)	T MAX (kg/mm ²) PLACA	T MAX (kg/mm ²) CANTONEIRA	FLECHA (mm)	X MAX (mm)	Y (mm)
800	120	252	221	11	6.4	1.1	140	242
1000	150	315	221	12	8	1.3	140	242
1200	180	378	221	12.8	9.6	1.4	140	242
1500	225	473	221	14	12	1.6	140	242
1800	270	567	221	15.3	14.3	1.8	140	242

TENSÃO LIMITE = 22.5 kg/mm² (P. SEGURANCA)

P SEGUR (Pa)	P DISTR (kg/m)	FH (kg)	FV (kg)	T MAX (kg/mm ²) PLACA	T MAX (kg/mm ²) CANTONEIRA	FLECHA (mm)	X MAX (mm)	Y (mm)
1200	180	378	221	12.8	9.6	1.4	140	242
1500	225	473	221	14	12	1.6	140	242
1800	270	567	221	15.3	14.3	1.8	140	242
2250	338	710	221	17.2	18	2.0	140	242
2700	405	851	221	19.1	21.4	2.3	140	242

Perfis Anc. Telescópica

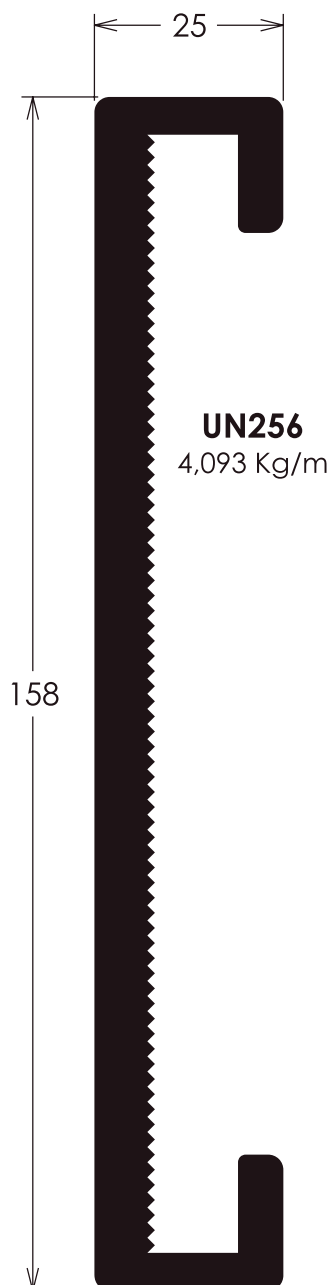
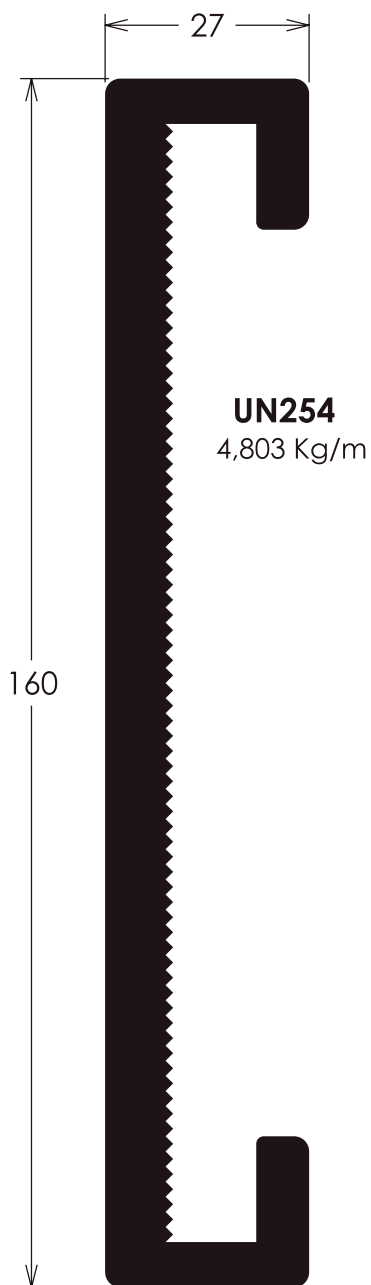

Perfis Anc. Telescópica

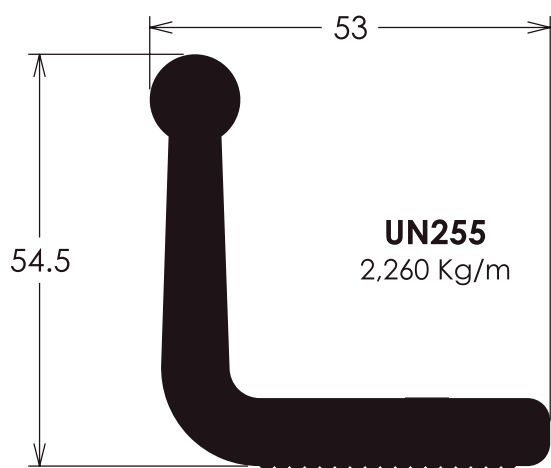
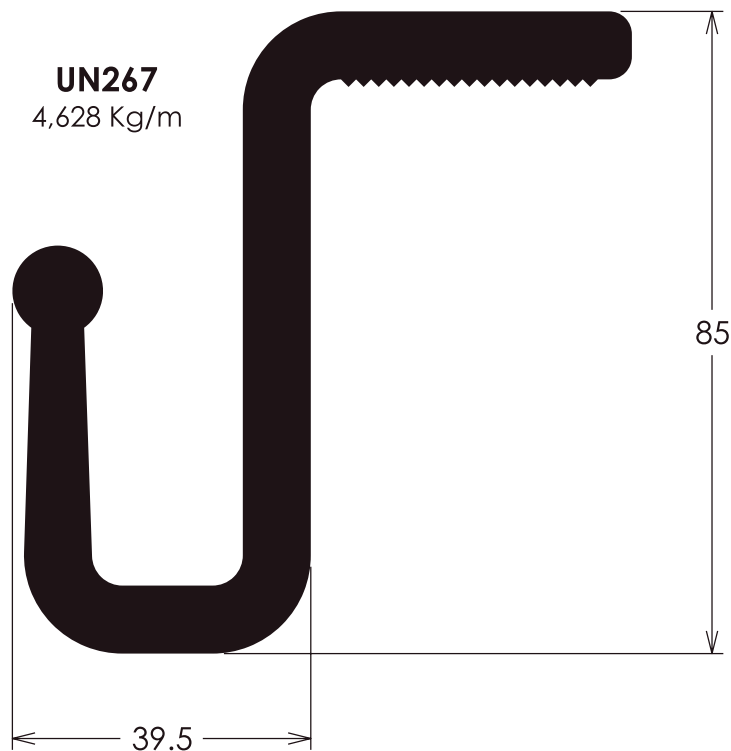

Perfis Anc. Telescópica

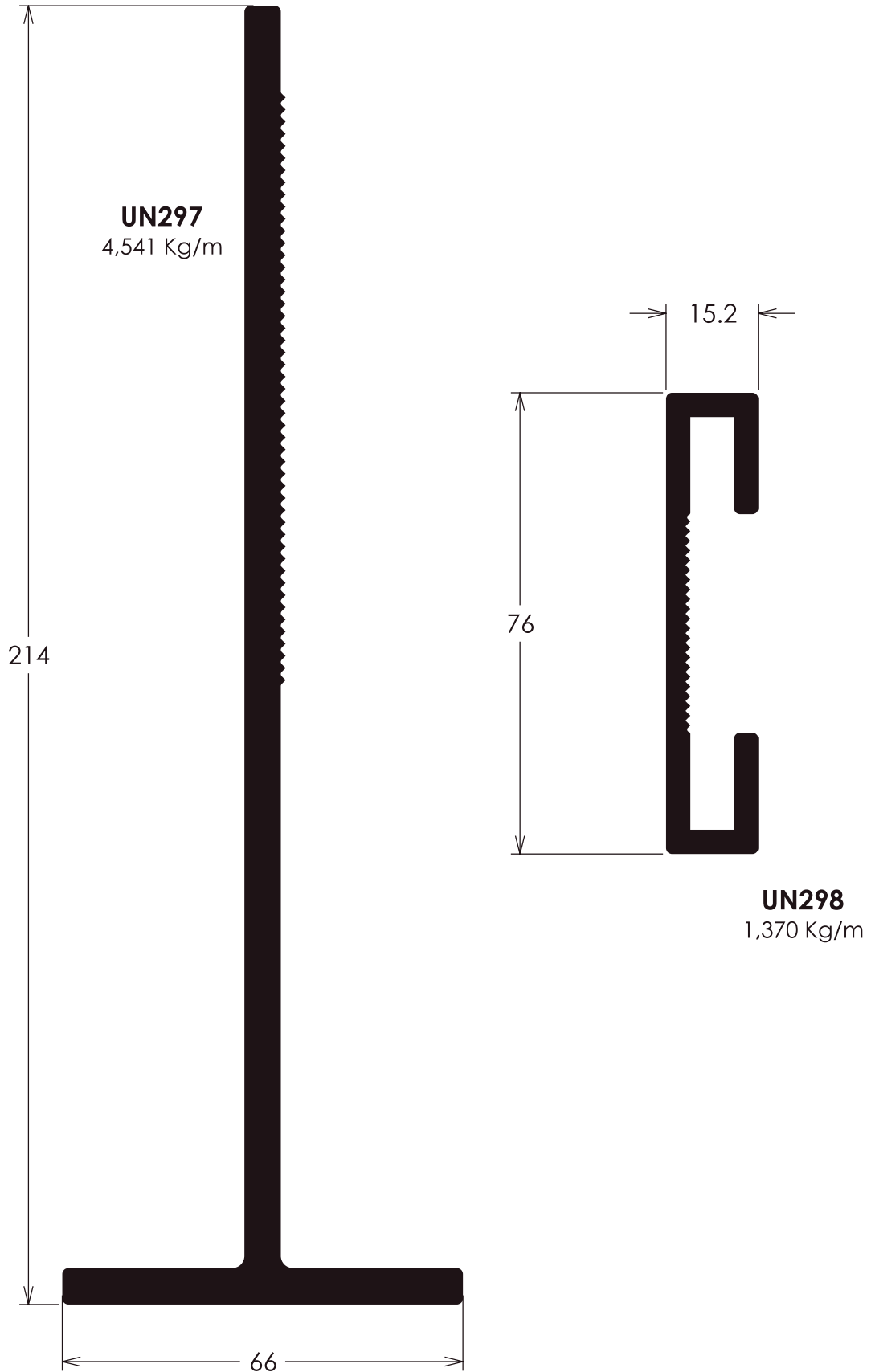

Módulo Fachada Extrema

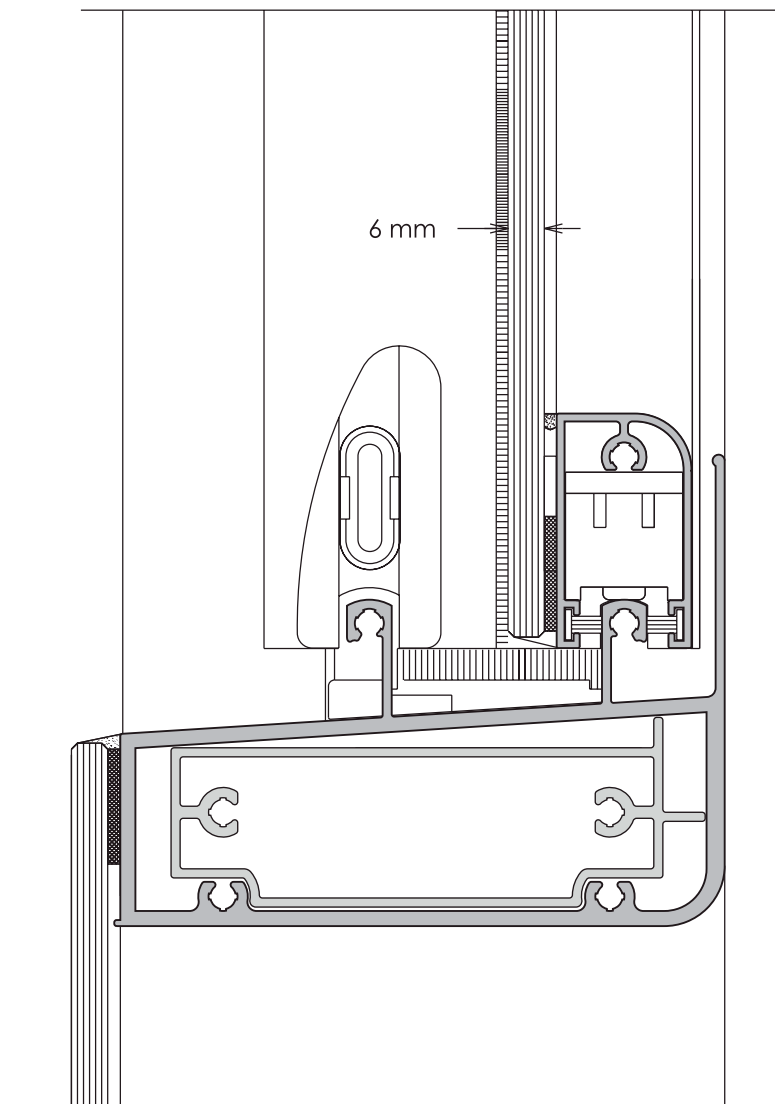

Montagem Fachada Extrema

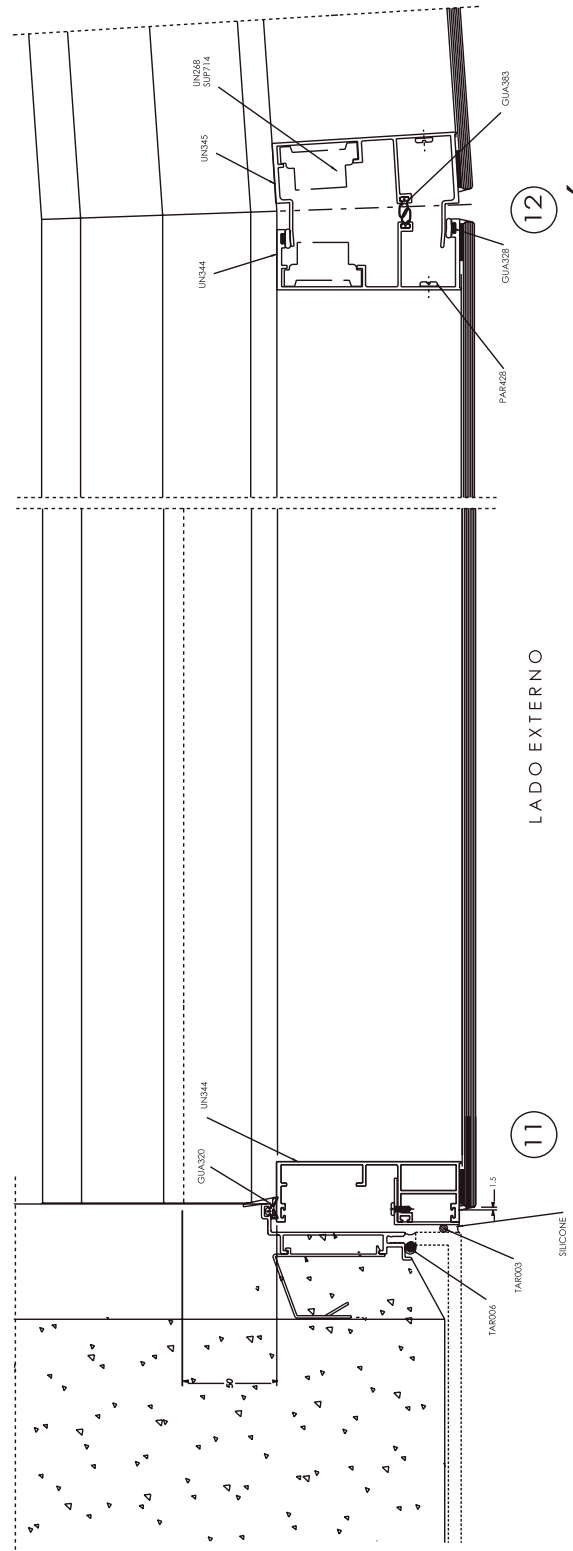
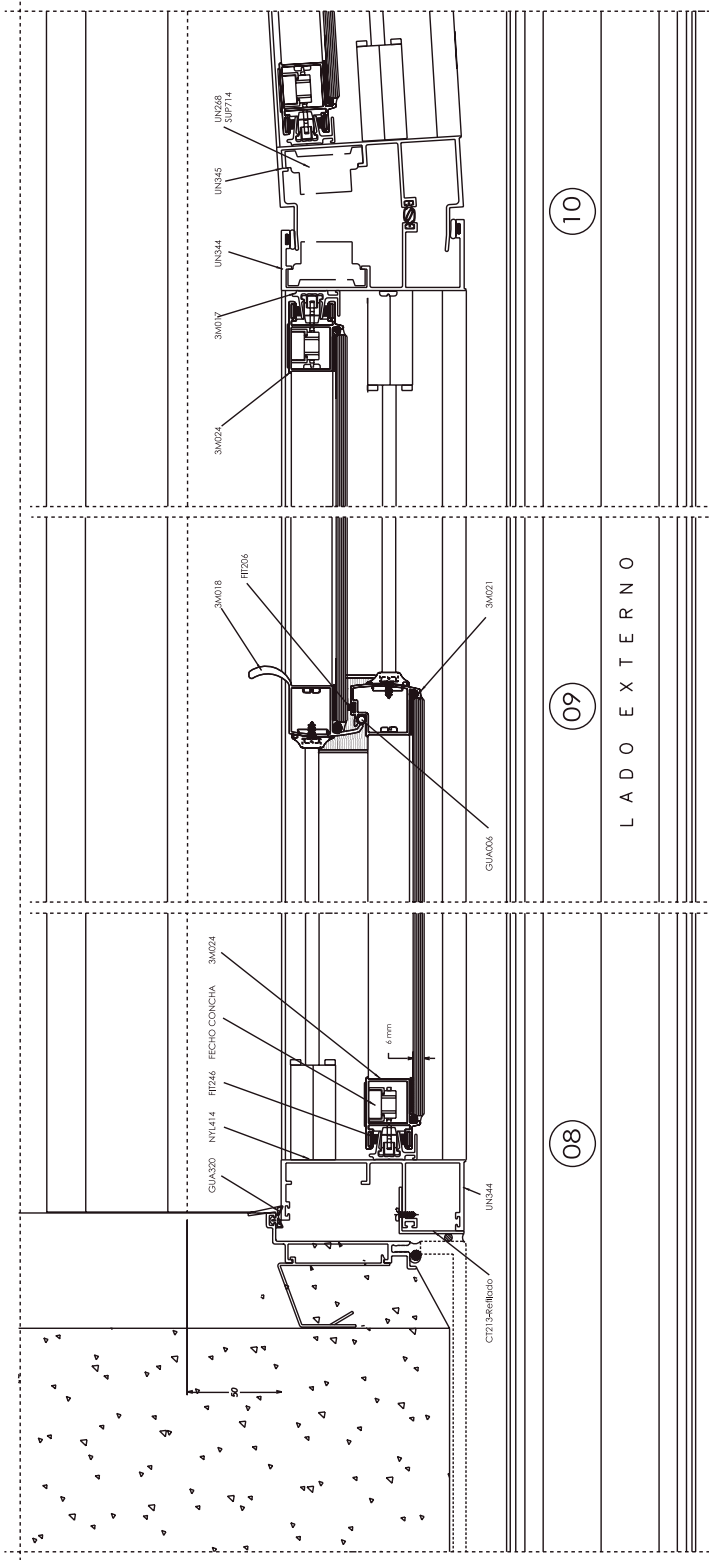

UNIT MÓDULO-EXTREMA

Perfis Fachada Extrema

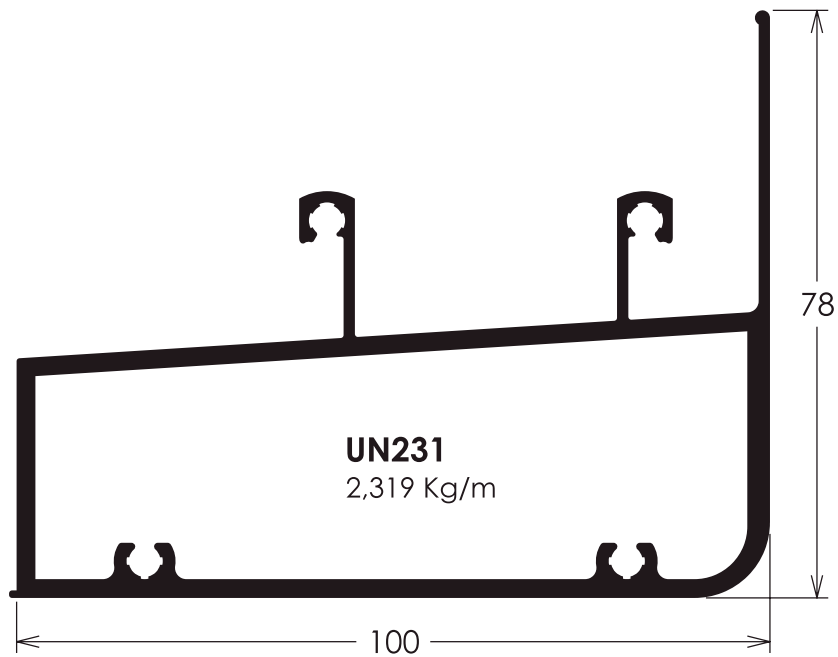
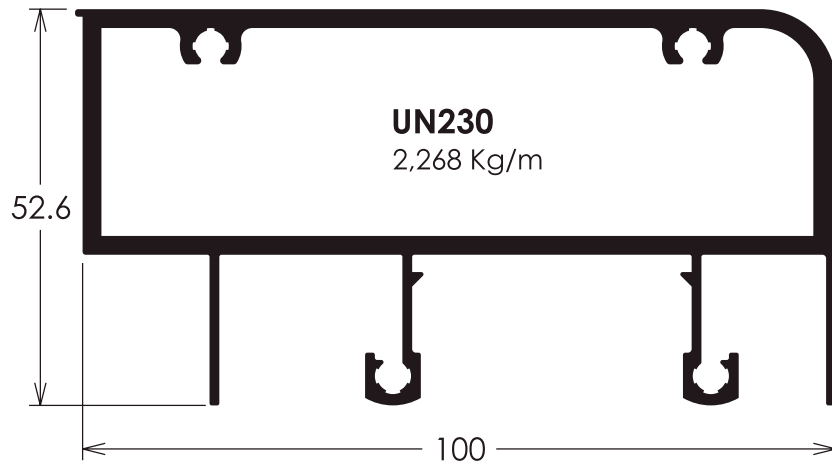
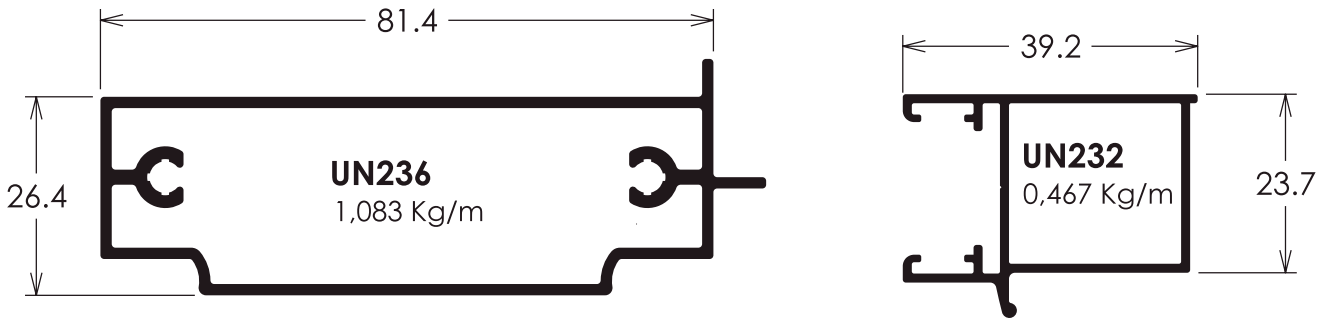

Perfis Módulos Diversos

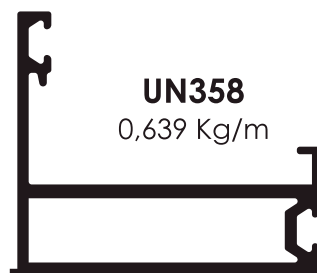
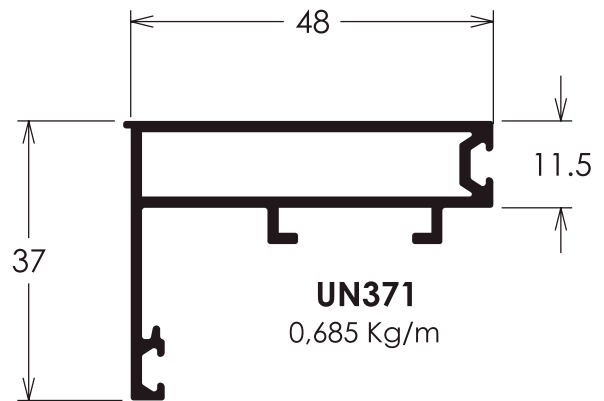
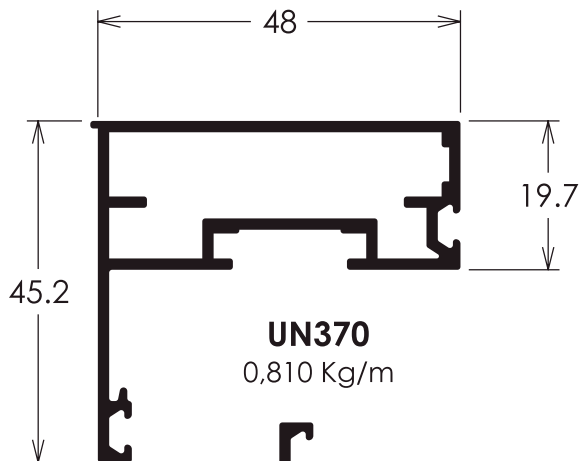
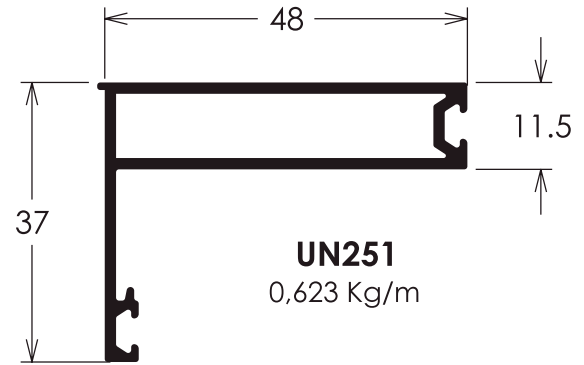
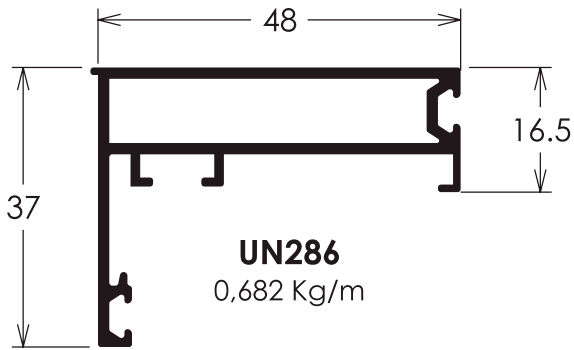
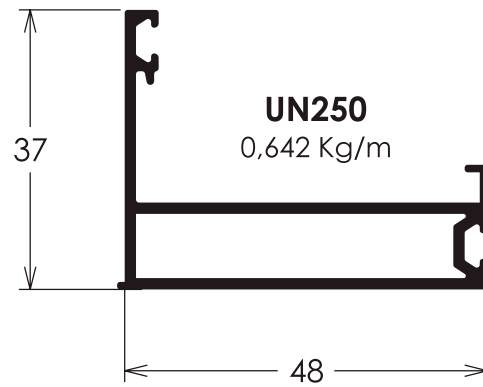
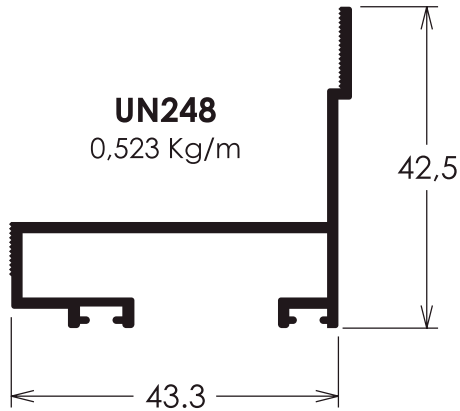

LC054
0,158 Kg/m

Perfis Módulos Diversos

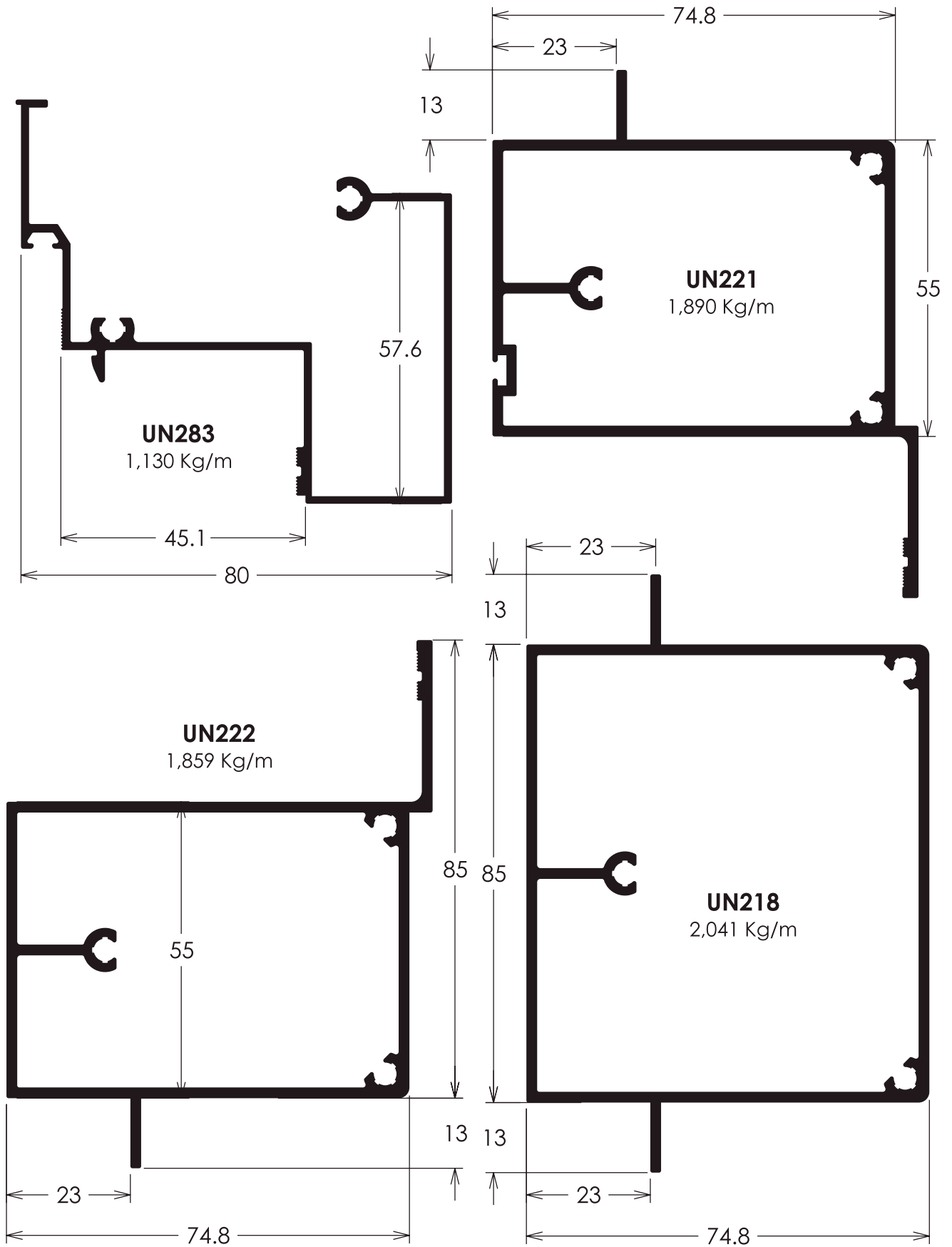

Perfis Módulos Diversos

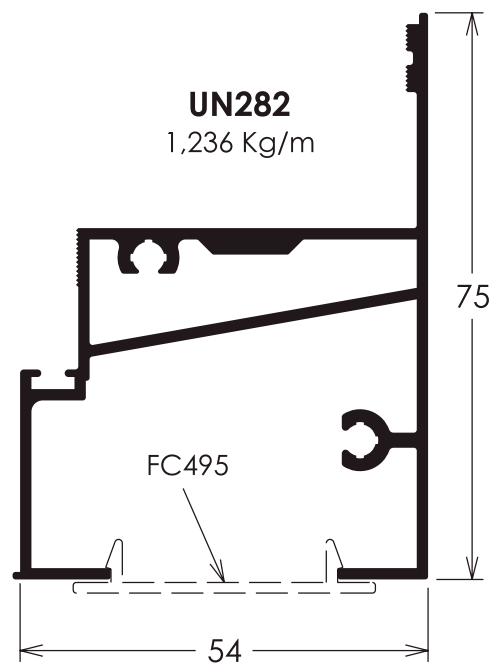
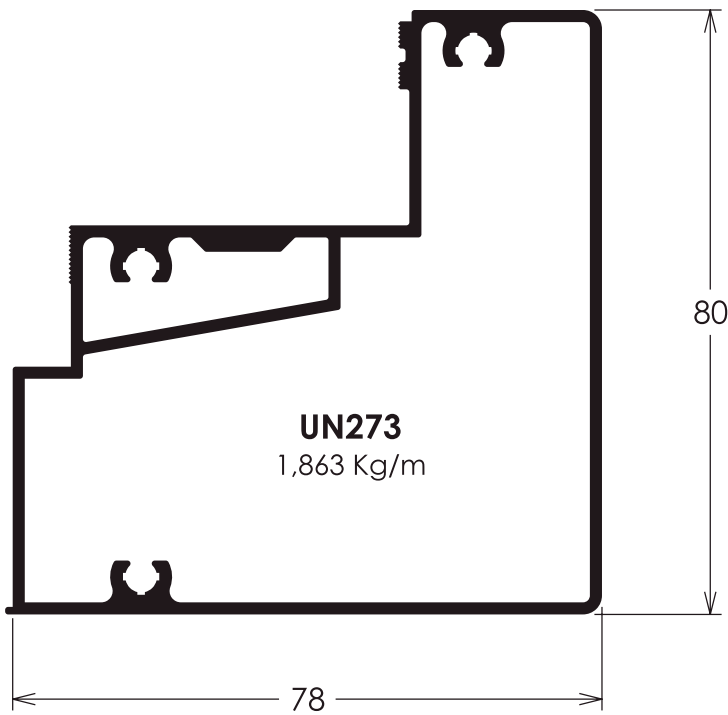
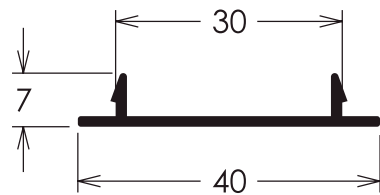
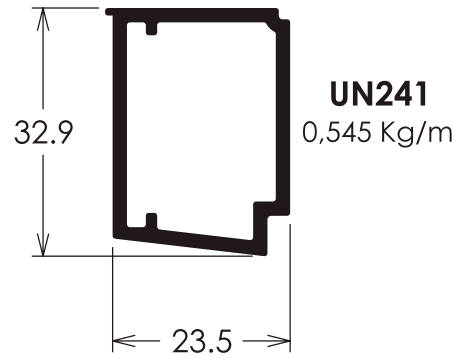
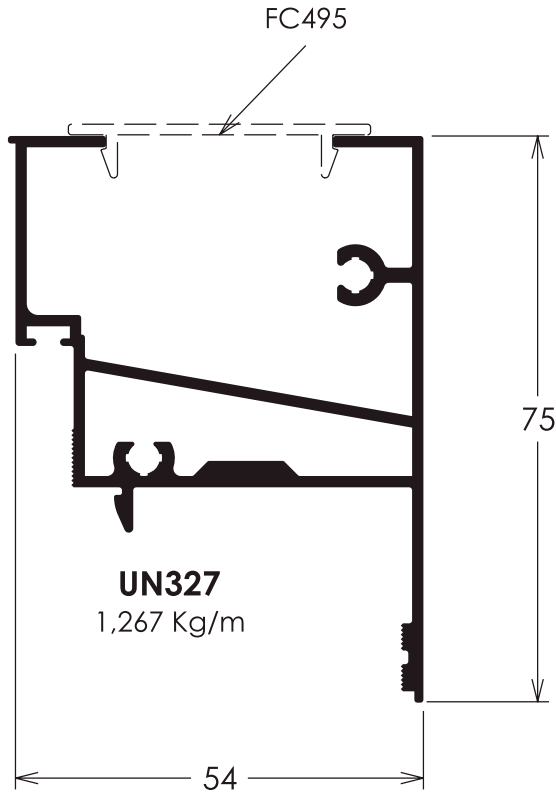

Perfis Módulos Diversos

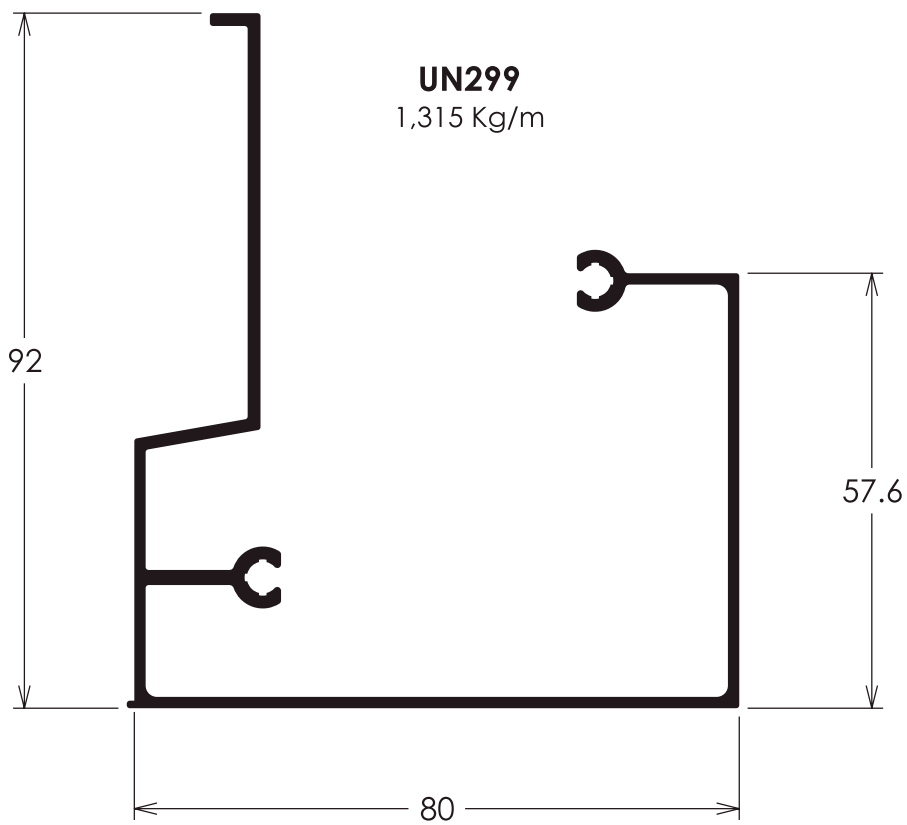
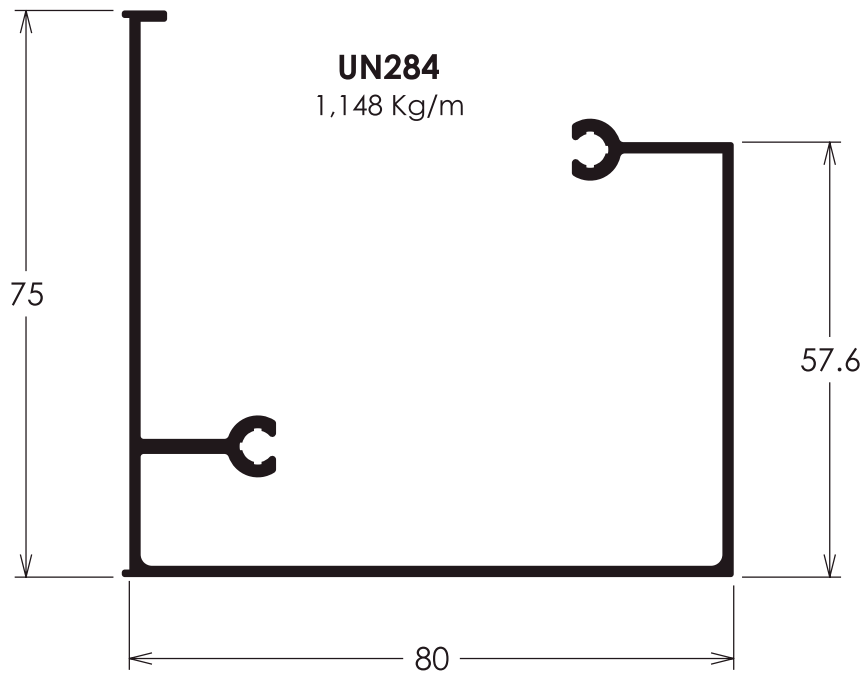

Perfis Módulos Diversos

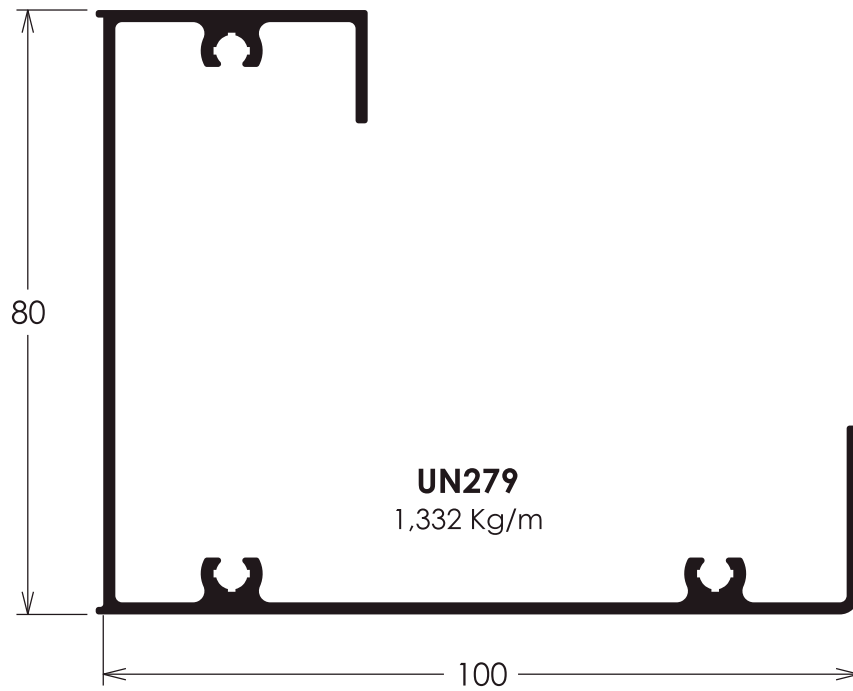

Perfis Módulos Diversos

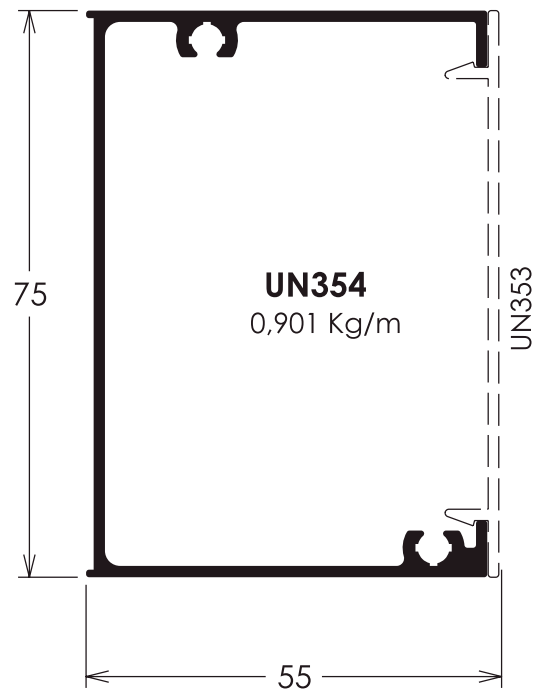
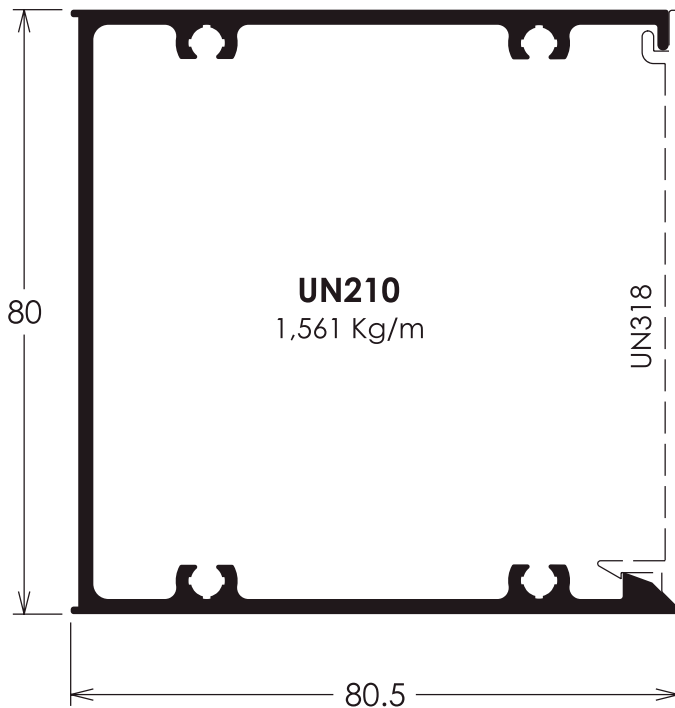
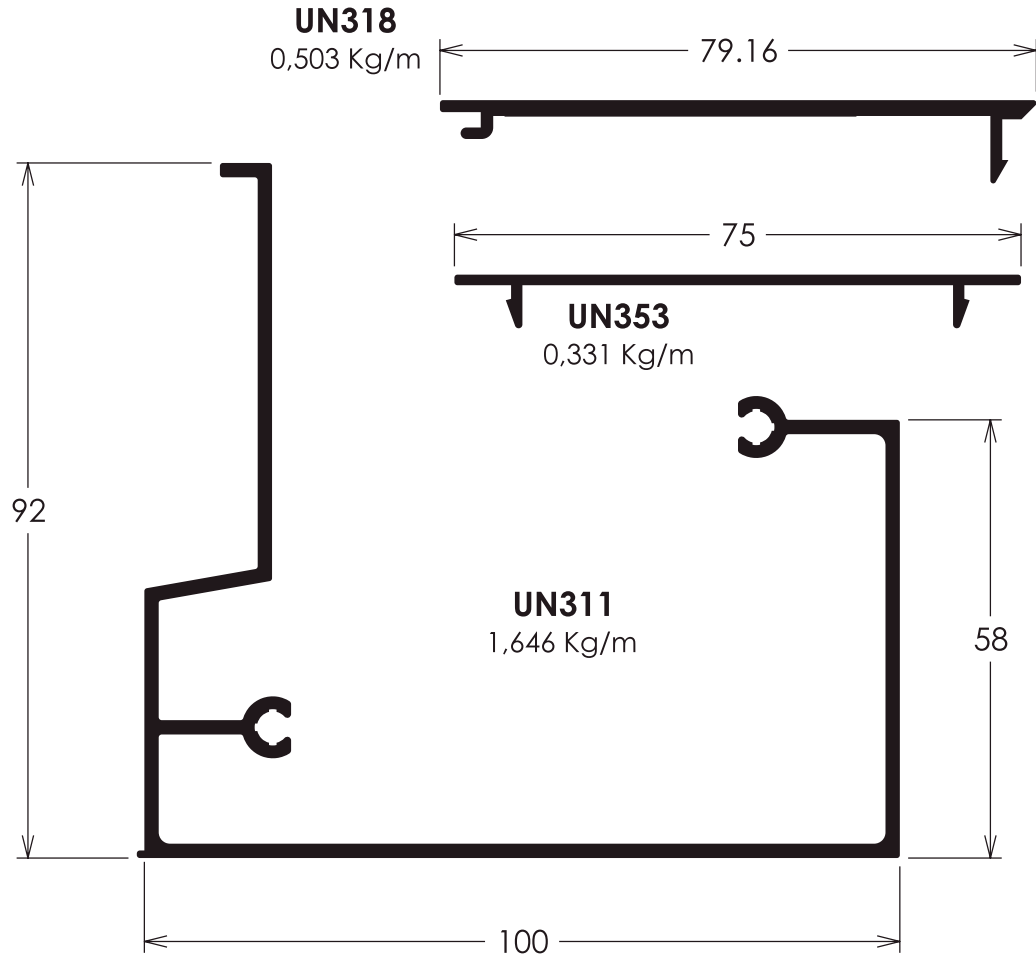

Perfis Módulos Diversos

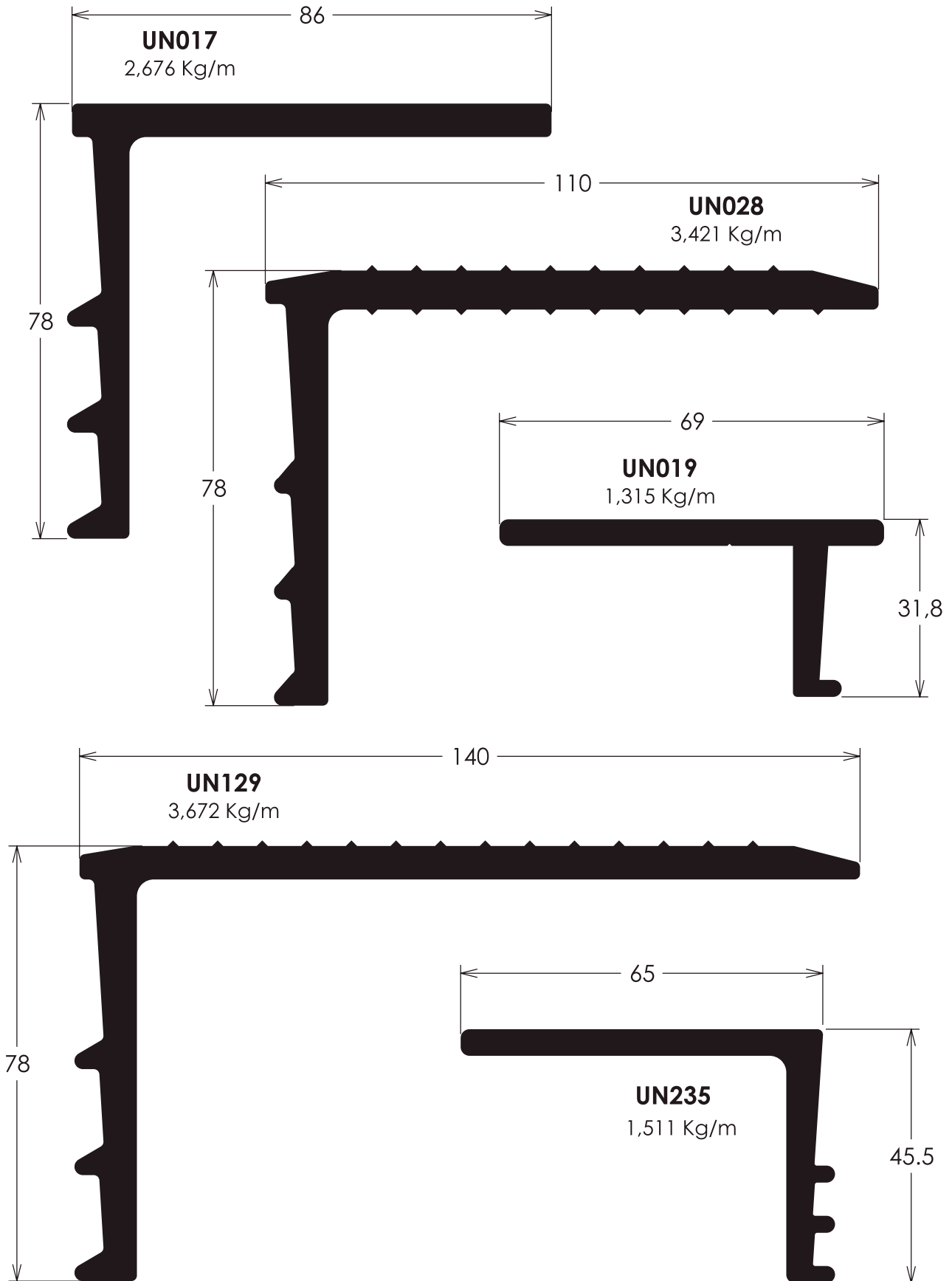

Perfis Módulos Diversos

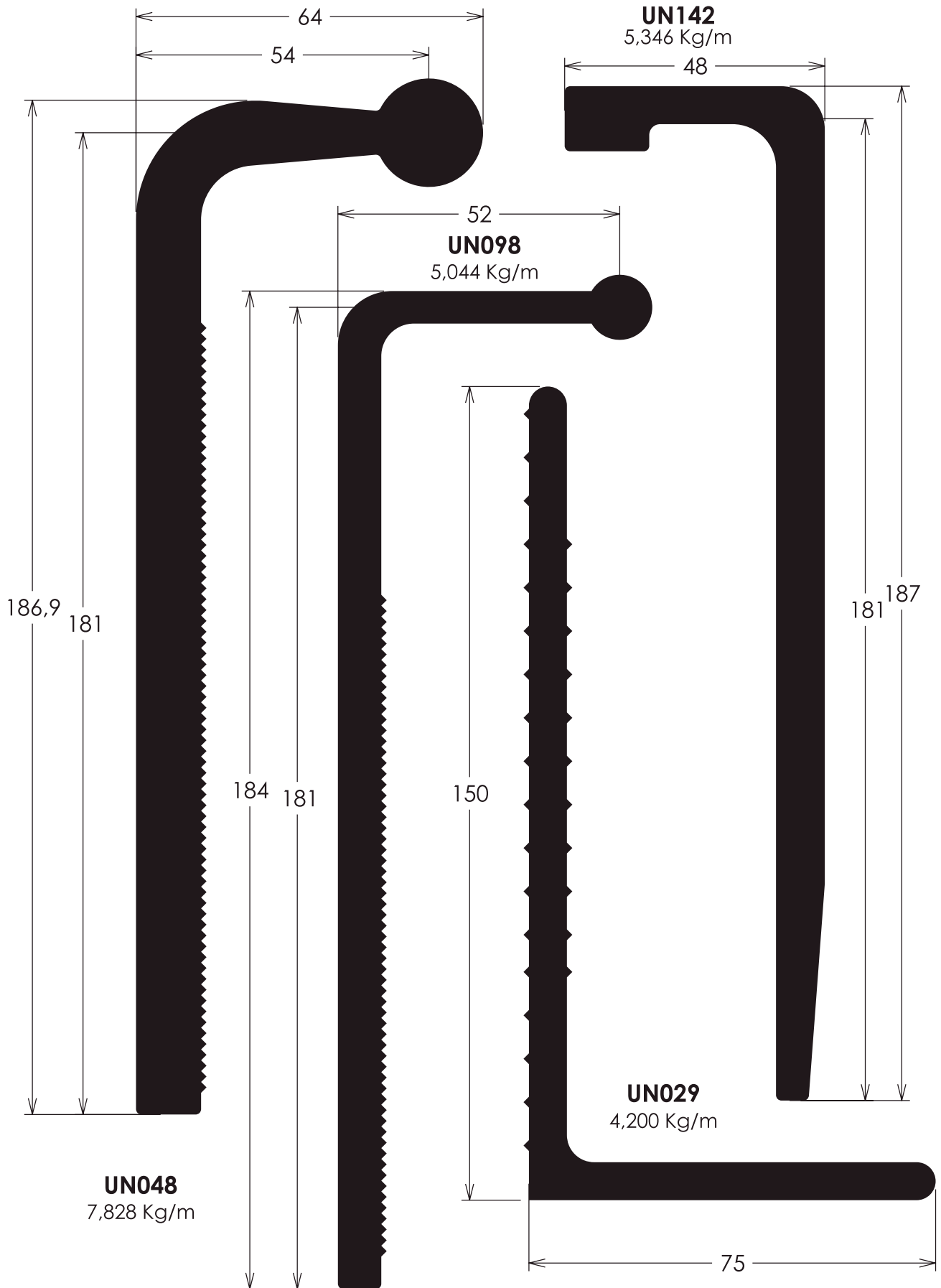

Perfis Módulos Diversos

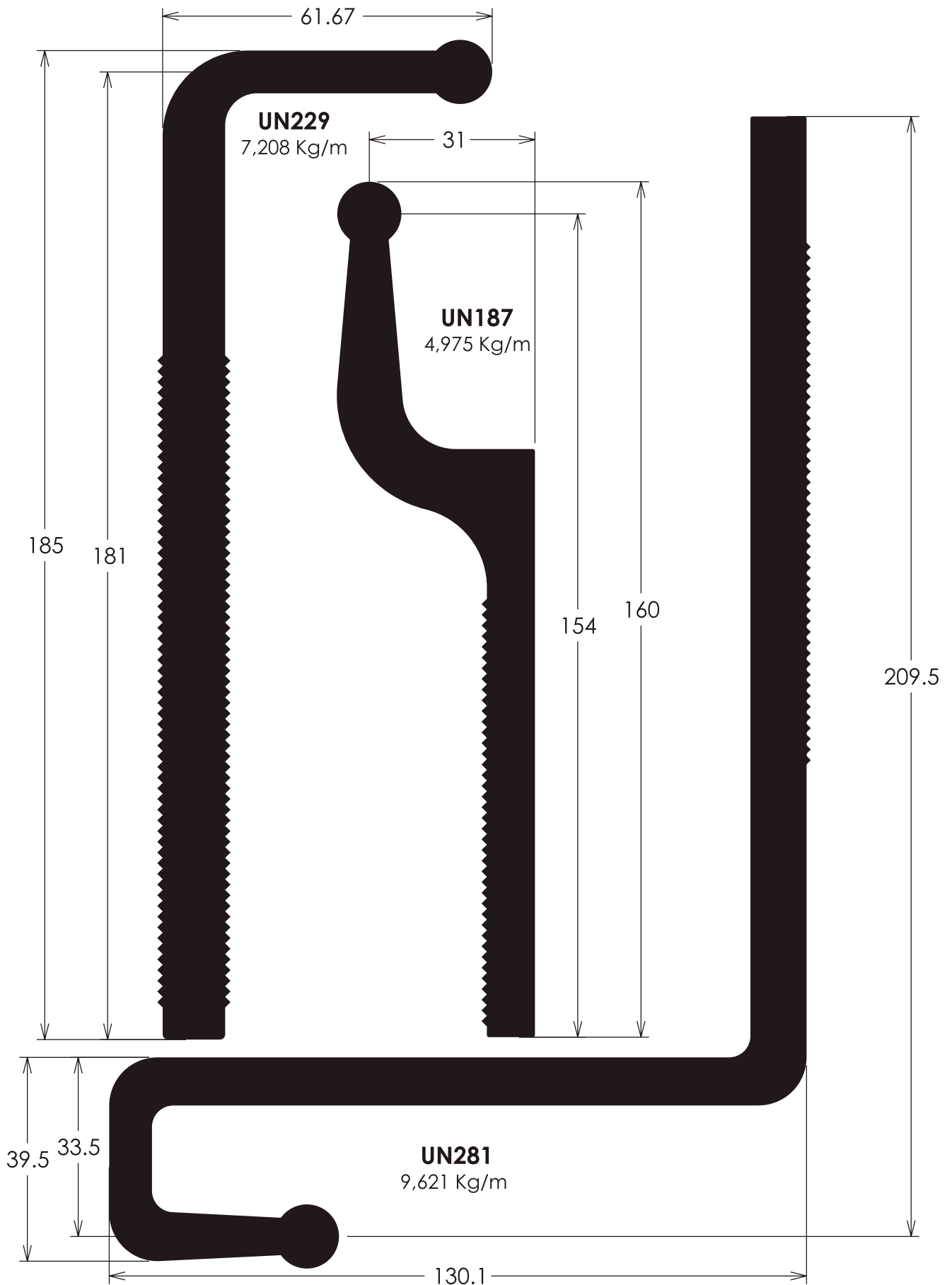

Perfis Módulos Diversos

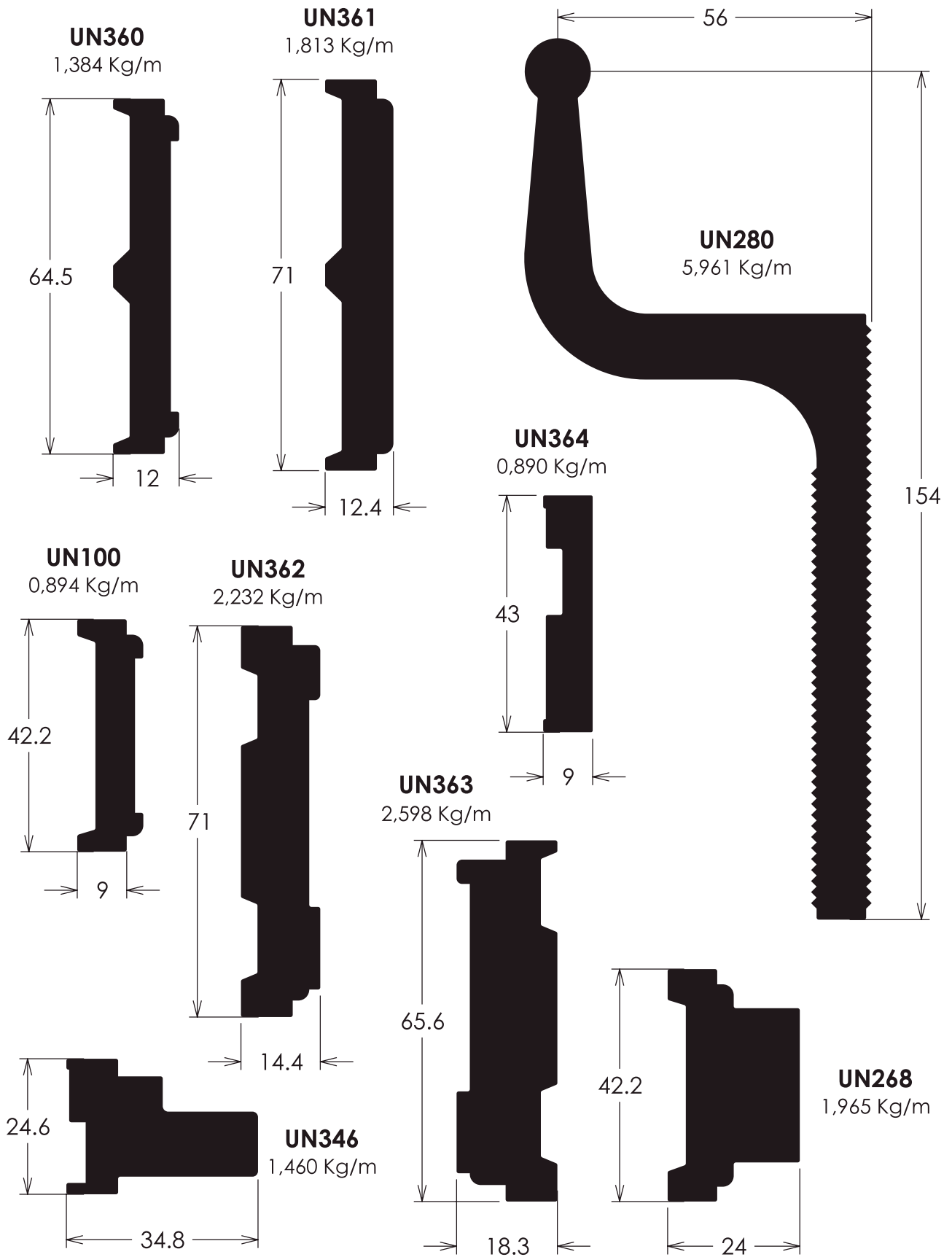

Perfis Módulos Diversos

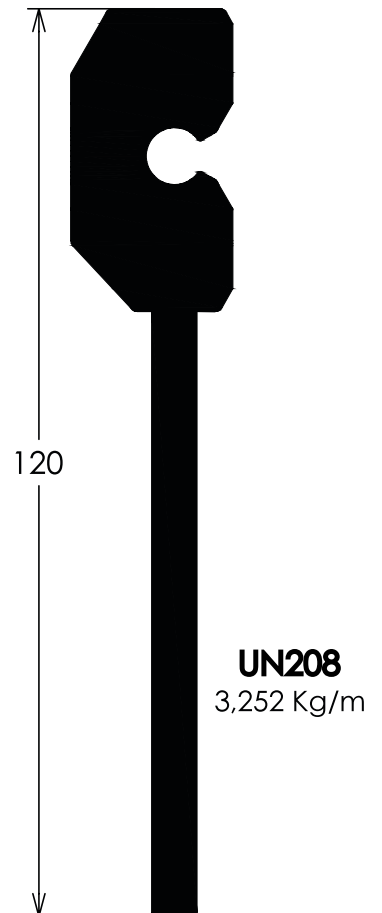
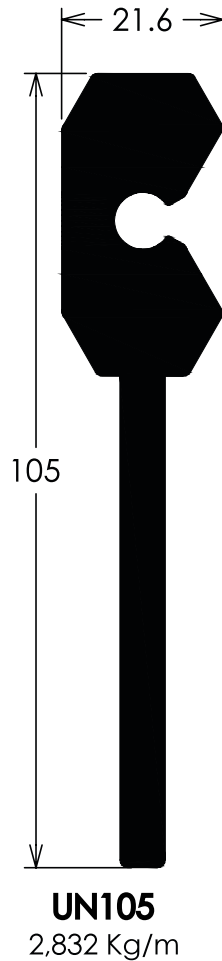
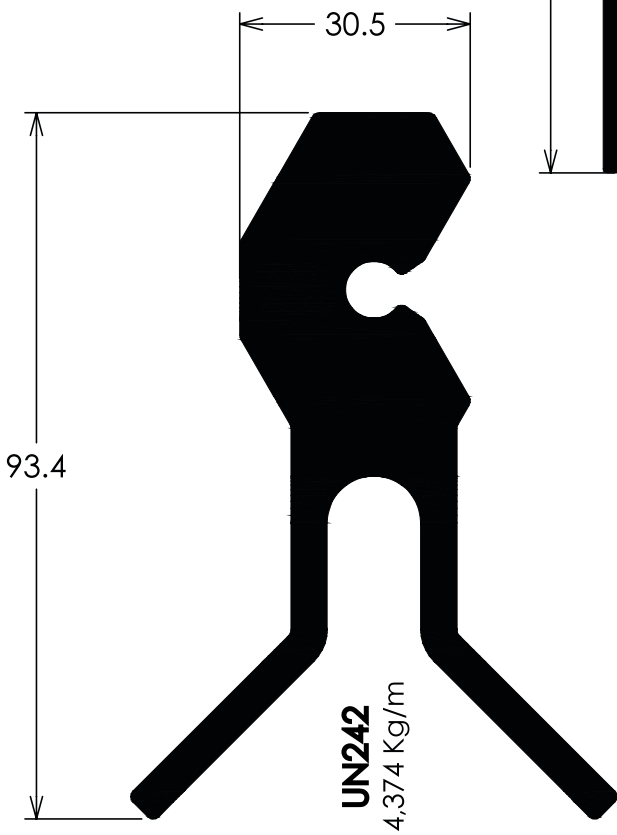
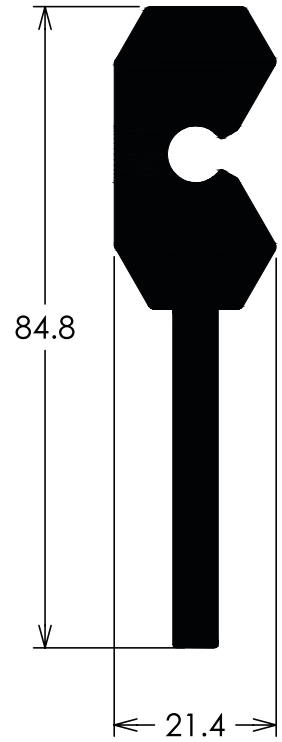
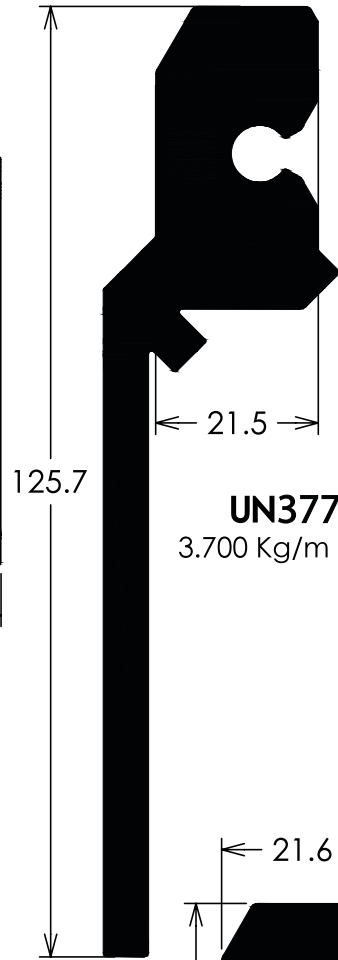
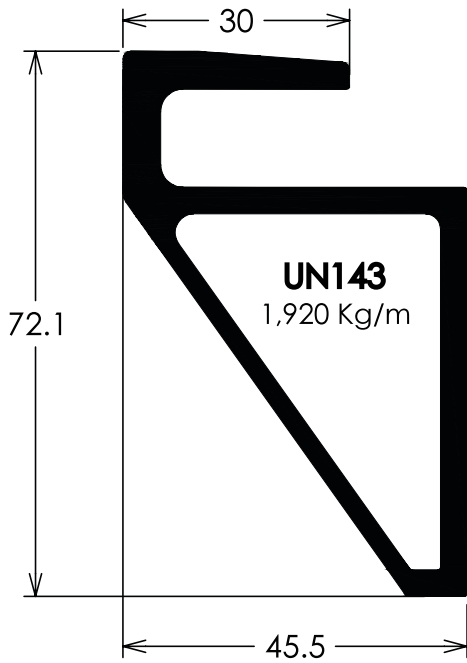

Perfis Módulos Diversos

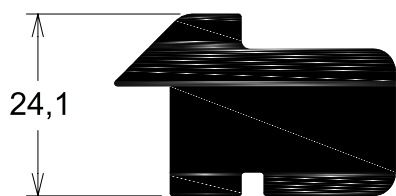

UN435
1,742 kg/m

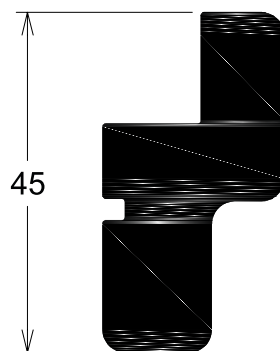

UN436
1,857 kg/m

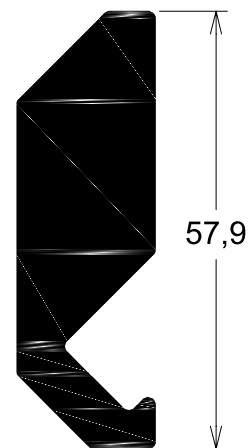

UN453
2.178 kg/m

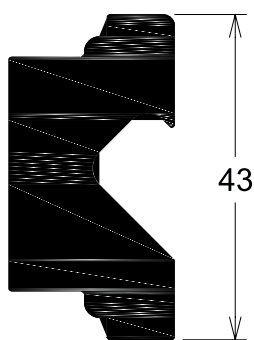

UN428
1,832 kg/m

Perfis Módulos Diversos

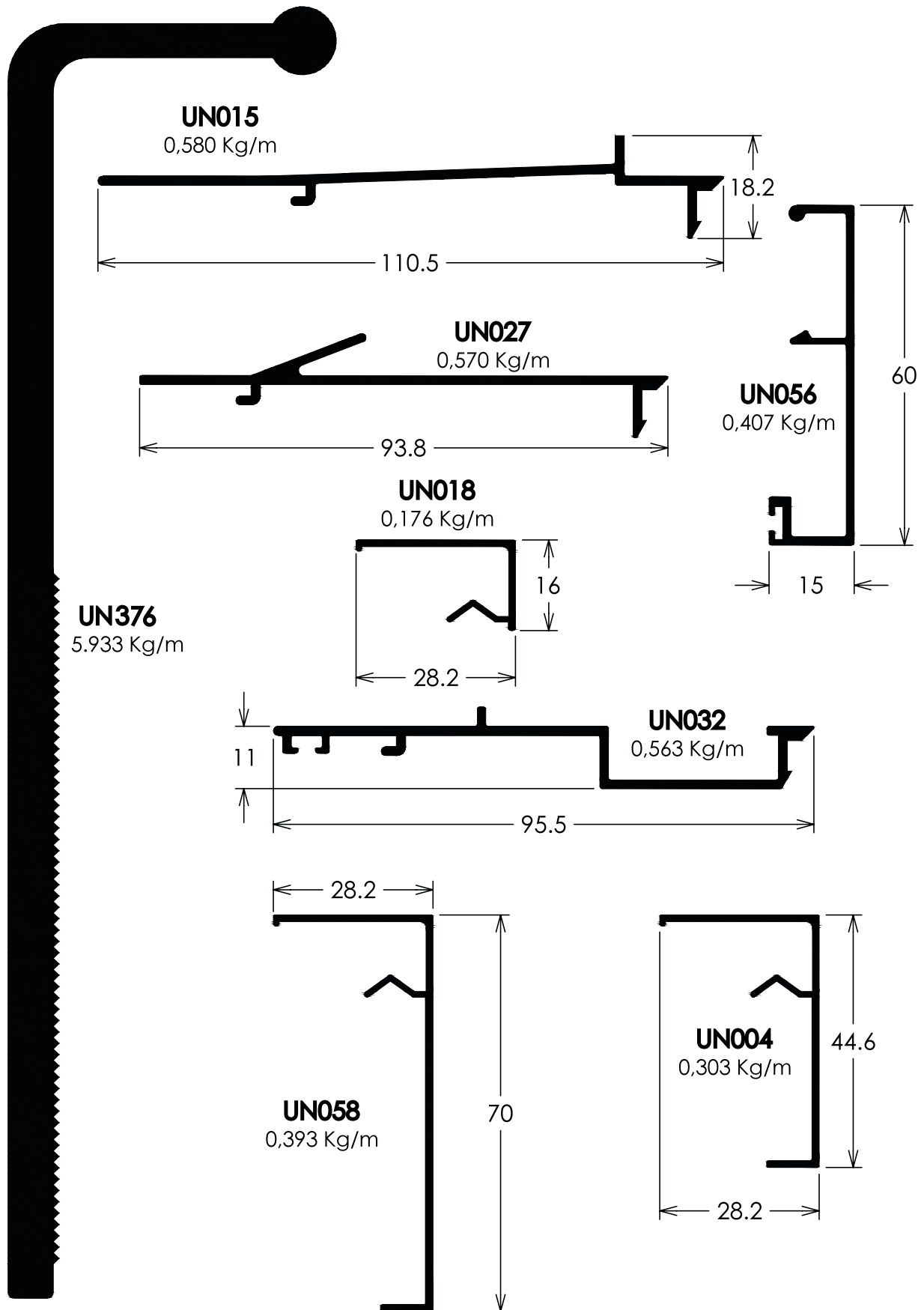

Perfis Módulos Diversos

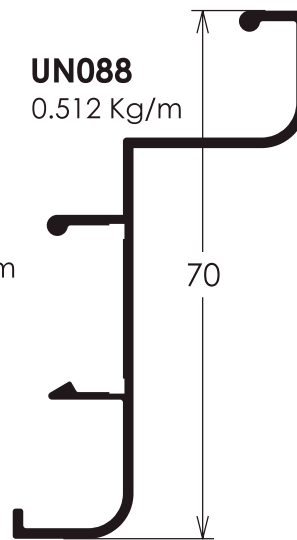
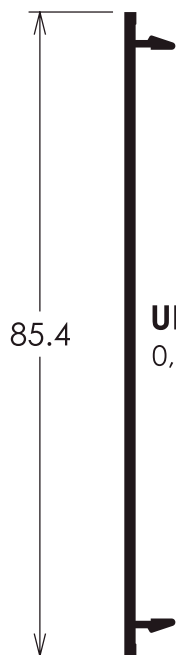
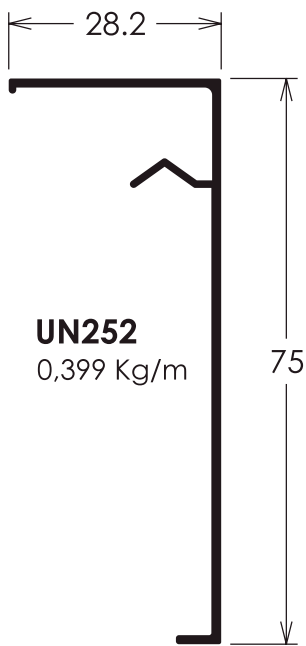
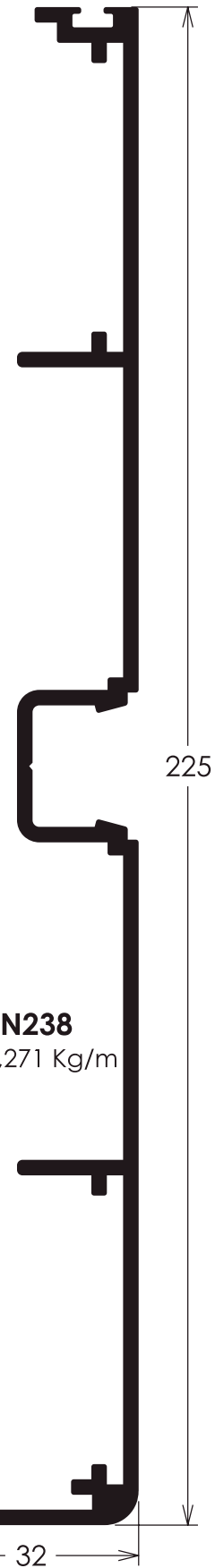
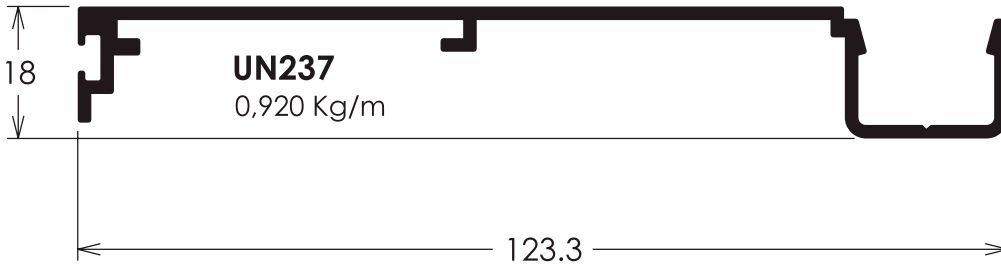
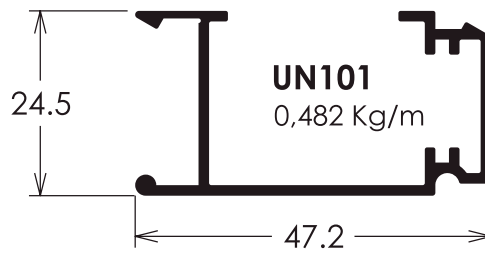
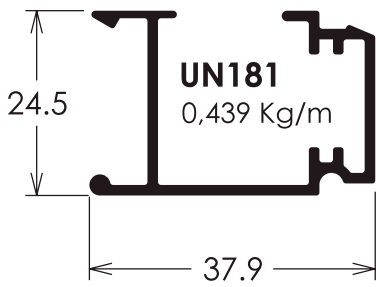
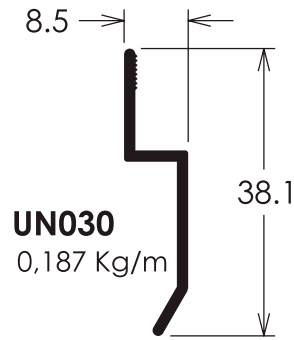
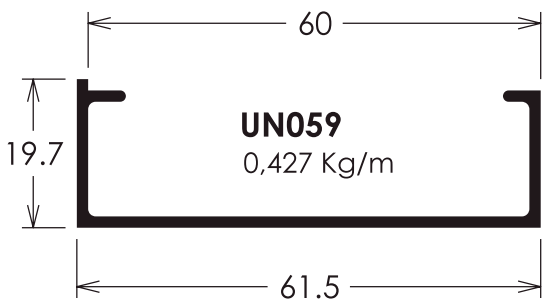

Perfis Módulos Diversos

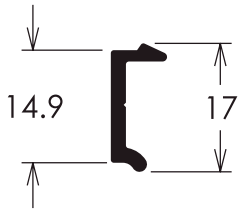

VL047
0,121 Kg/m

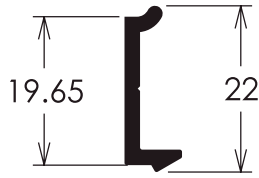

FC400
0,152 Kg/m

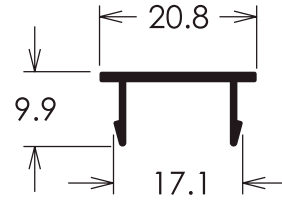

FC368
0,130 Kg/m

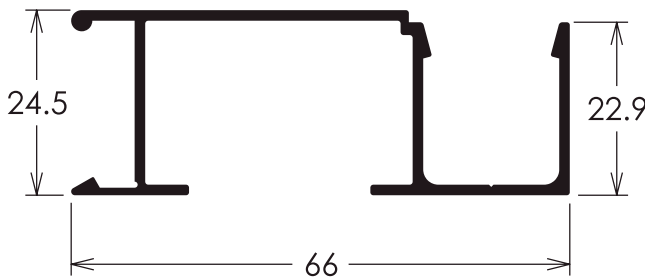

FC369
0,605 Kg/m

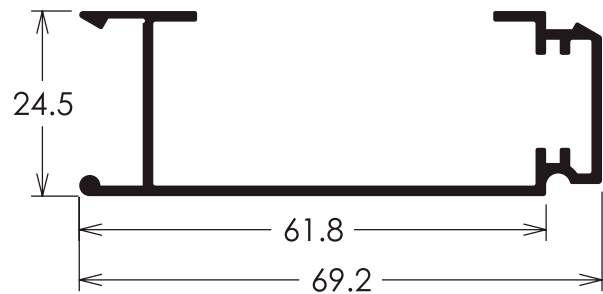

LC041
0,605 Kg/m

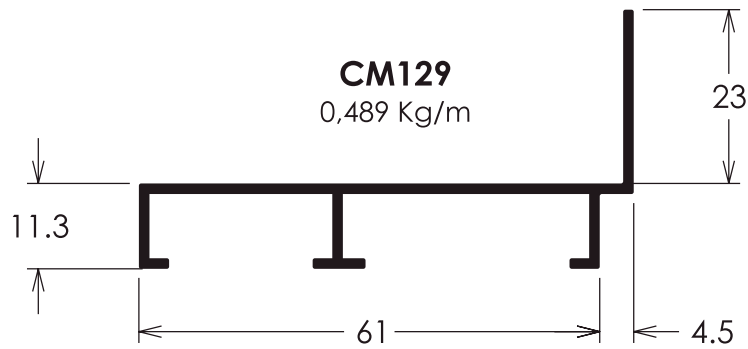

CM129
0,489 Kg/m

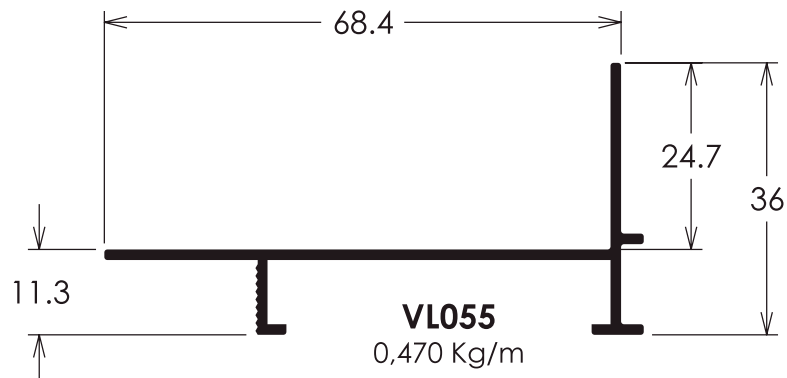

VL055
0,470 Kg/m

Perfis Módulos Diversos

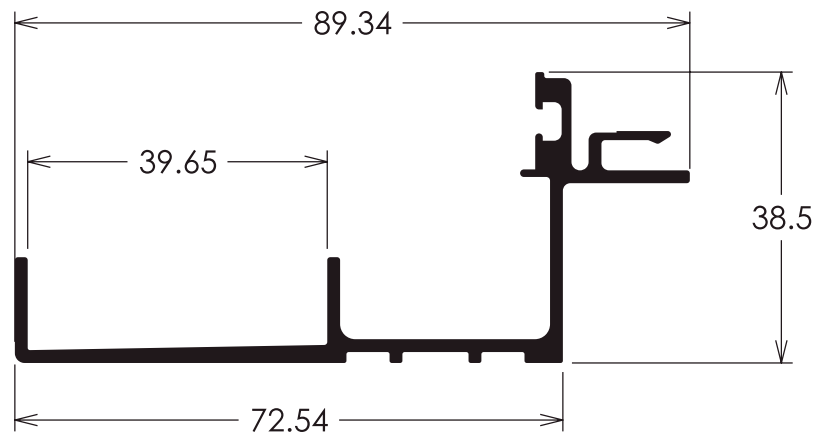
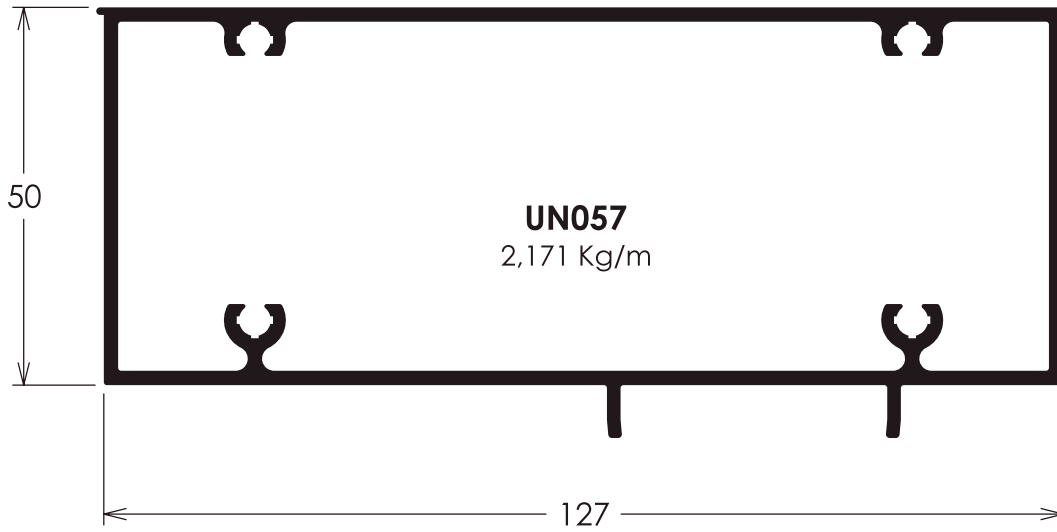

UN002
0,887 Kg/m

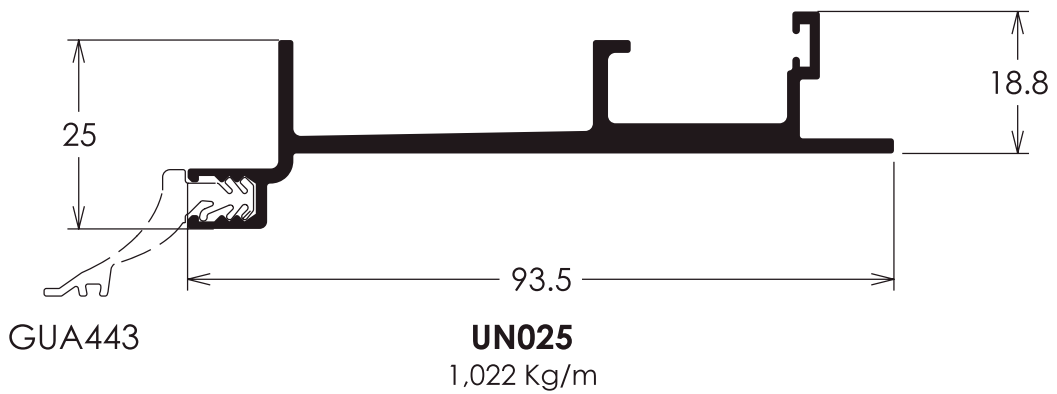

Perfis Módulos Diversos

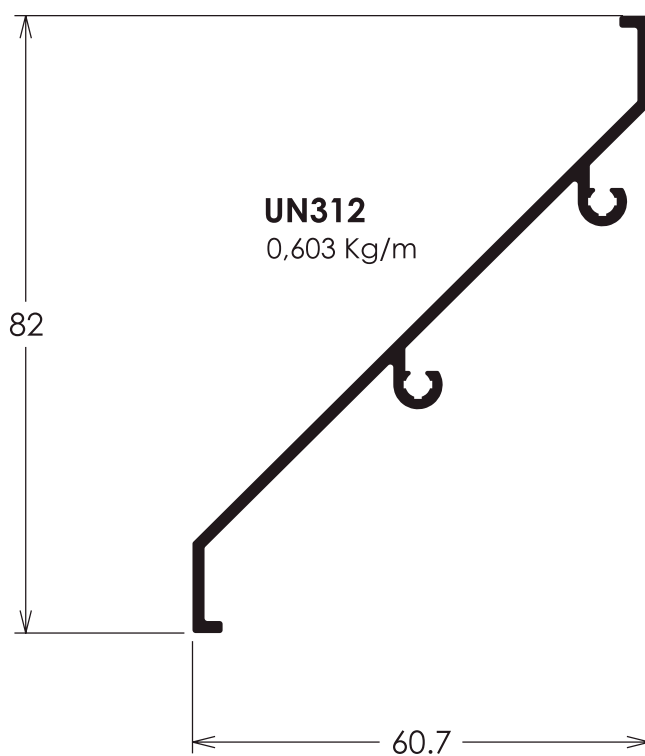

Perfis Módulos Diversos

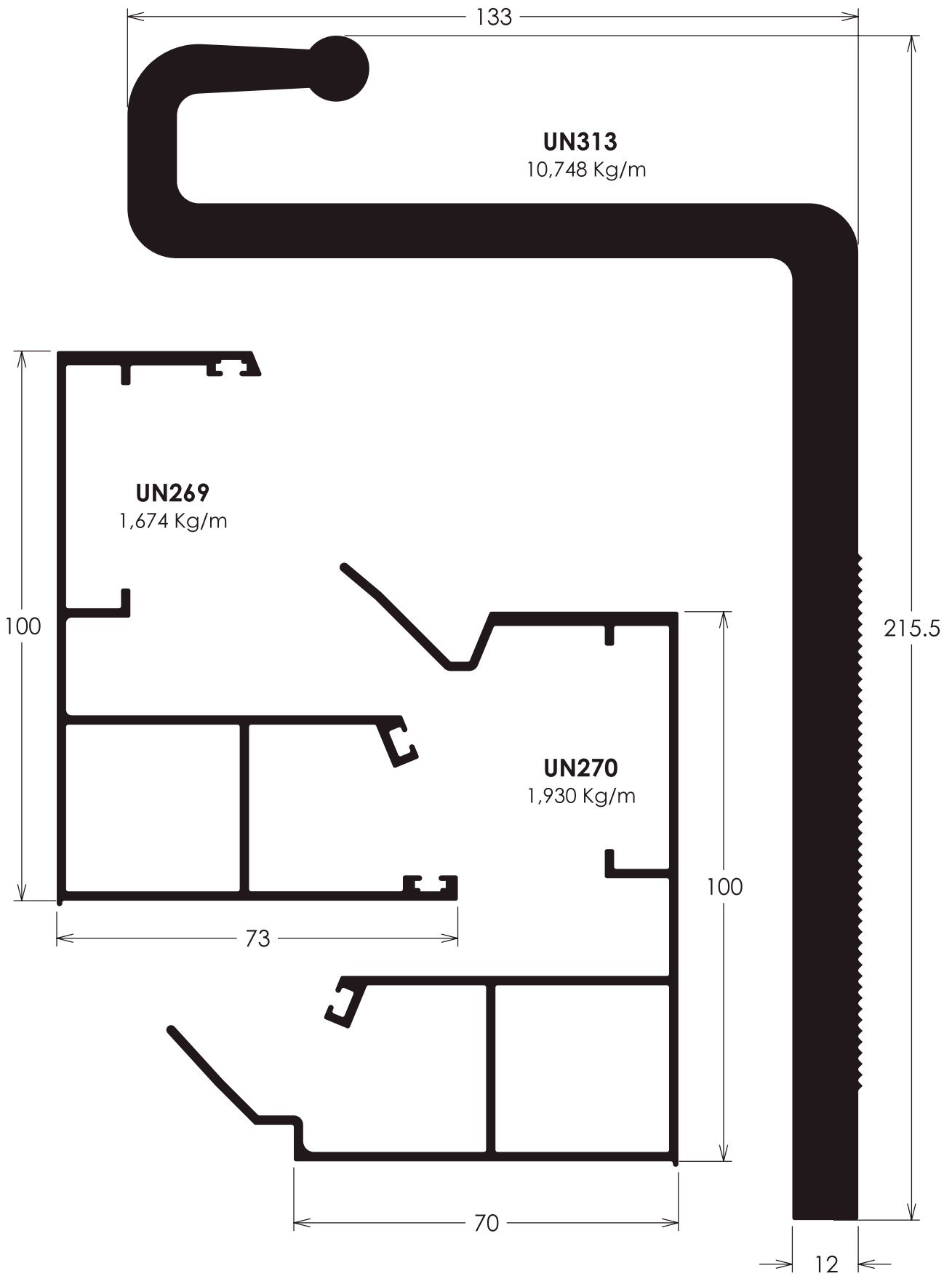

Esquema de Montagem

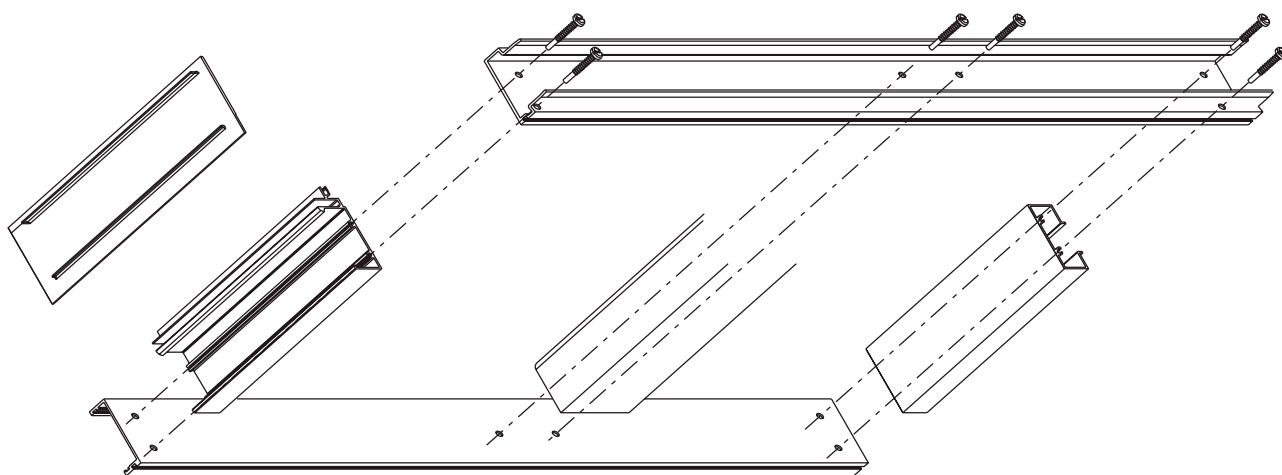
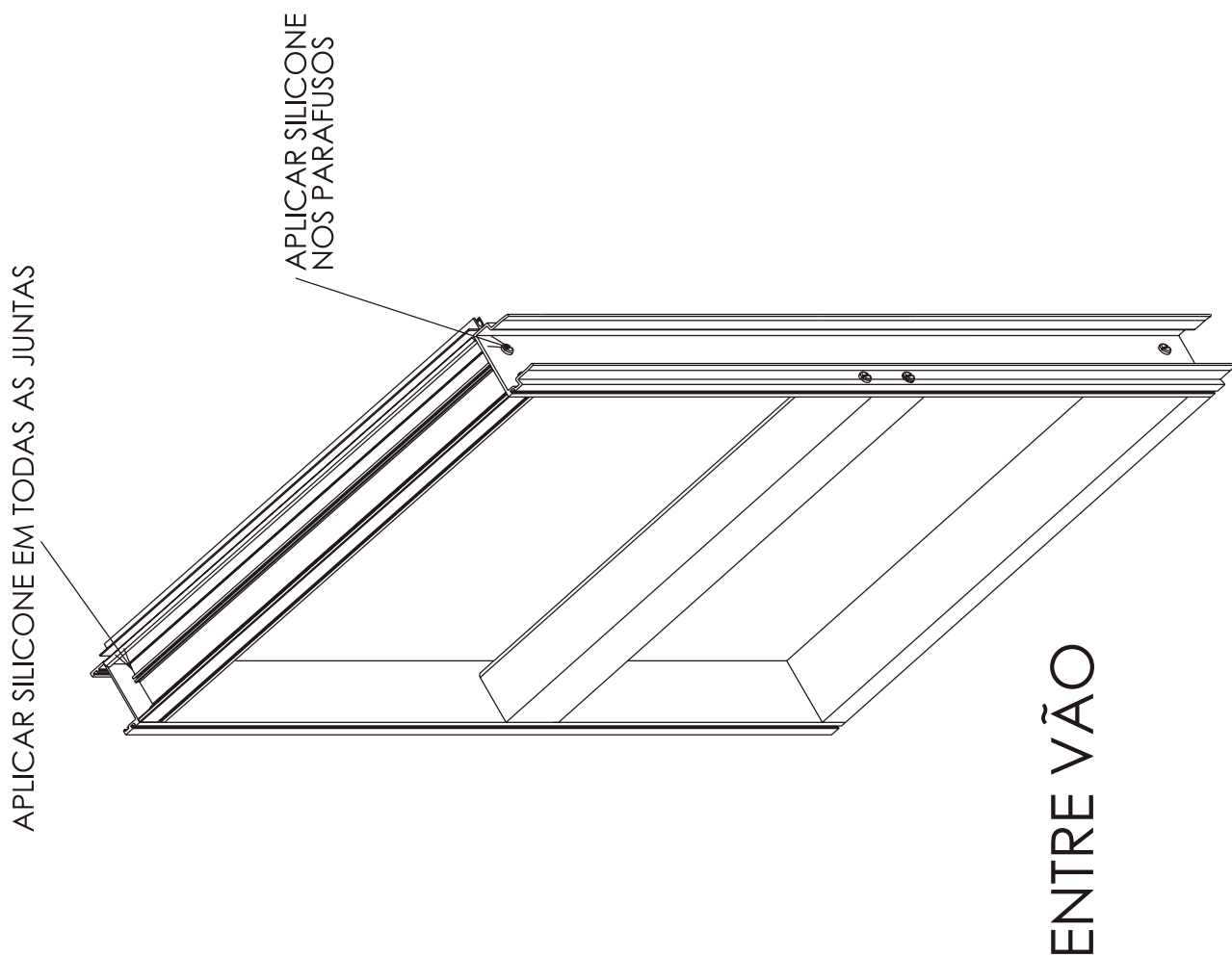

Cód.	Pág.
ANC983	U-06
ANC990	U-07
ANC991	U-10
ANC992	U-08
ANC995	U-10
ANC996	U-01
ANC997	U-01
ANC998	U-02
ANC999	U-02
ANC1000	U-03
ANC1001	U-03
ANC1002	U-04
ANC1003	U-04
ANC1004	U-05
ANC1005	U-05
ANC1006	U-06
ANC1007	U-07
ANC1008	U-09
ANC1009	U-09
ANC1011	U-08
ANC1012	U-17
ANC1014	U-25
ANC1020	U-20
ANC1021	U-14
ANC1022	U-13
ANC1027	U-23
ANC1028	U-24
ARR759	U-07
BRA588	T-02
BRA589	T-02
BRA590	T-02
BRA591	T-02
BRA762	T-01
BRA763	T-01
BRA764	T-01
BRA806	T-01
BRA807	T-01
BRA808	T-01
BRA809	T-02
BRA810	T-02
BRA811	T-02
BRA812	T-02
BRA813	T-02
CHU794	T-06
CHU795	T-06
FEC450	T-02
FEC451	T-02
FEC1070	T-03
FIT206	T-05
GUA007	T-05
GUA307	T-05
GUA320	T-05
GUA328	T-05
GUA349	T-05
GUA350	T-05
GUA381	T-05

Cód.	Pág.
GUA383	T-05
GUA384	T-05
GUA387	T-05
GUA388	T-05
GUA389	T-05
GUA390	T-05
GUA410	T-05
GUA438	T-05
GUA441	T-05
GUA442	T-05
GUA443	T-05
KIT624	T-03
KIT640	T-03
LC054	T-03
NYL039	T-05
NYL490	T-05
PAR063	T-06
PAR428	T-06
PAR437	T-06
PAR670	T-06
PAR691	T-06
PAR698	T-06
PAR1052	T-06
PAR1053	T-06
PAR1059	T-06
PAR1061	T-06
PAR1071	T-06
PAR1072	T-06
PAR1073	T-06
PAR1074	T-06
PAR1075	T-06
PAR1076	T-06
PAR1077	T-06
PAR1084	T-06
PAR1085	T-06
SUP698	U-11
SUP711	U-11
SUP713	U-34
SUP714	U-33
SUP715	U-33
SUP717	U-29
SUP718	U-28
SUP719	U-28
SUP720	U-27
SUP721	U-33
SUP743	U-31
SUP744	U-31
SUP745	U-21
SUP747	U-30
SUP748	U-30
SUP749	U-18
SUP750	U-19
SUP751	U-32
SUP753	U-22
TAR003	T-05
TAR006	T-05

CONJUNTO DO BRAÇO - ALUMÍNIO - CAIXA 15 MM

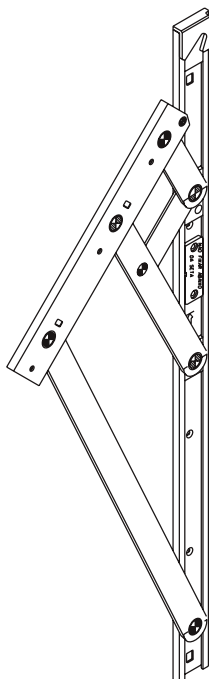

CÓDIGO	Dimensão (mm)	Altura da Folha (mm)	Largura da Folha (mm)	CARGA MÁXIMA
BRA762	342	Min. 390 Max. 600	Max. 1500	22Kg
BRA763	600	Min. 640 Max. 1000	Max. 1500	35Kg
BRA764	951	Min. 1000 Max. 1200	Max. 1500	45Kg

CONJUNTO DO BRAÇO - INOX - CAIXA 15 MM

CÓDIGO	Dimensão (mm)	Altura da Folha (mm)	Largura da Folha (mm)	CARGA MÁXIMA
BRA806	313,5	Max. 600	Max. 1500	22Kg
BRA807	512	Max. 1000	Max. 1500	35Kg
BRA808	617	Max. 1200	Max. 1500	45Kg

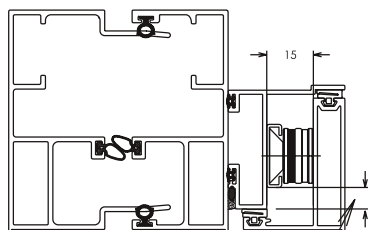

Obs: Verificar no catálogo do fornecedor as referências para instalação dos braços

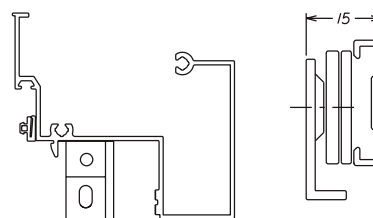

DETALHE DE USO

Braço Maxim-ar
Cor: preto, fosco e branco

Projetos, perfis, componentes, códigos e sistemas estão sujeitos a alteração sem prévio aviso.

CONJUNTO DO BRAÇO - INOX - CAIXA 17 MM

CÓDIGO	COMP. A	FOLHA MÁXIMA		CARGA MÁXIMA	ABERTURA MÁXIMA
		ALTURA	LARGURA		
BRA809	313	600	1500	22KG	20°
BRA810	356	800	1500	40 KG	20°
BRA811	516	1500	1500	75KG	15°
BRA812	562	1500	1500	100 KG	15°
BRA 813	662	1500	1500	125 KG	15°

EMBALAGEM 1 PAR

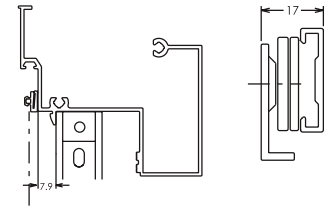
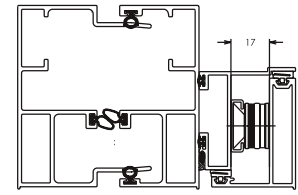

DETALHE DE USO

Braço Maxim-ar
Cor: preto, fosco e branco

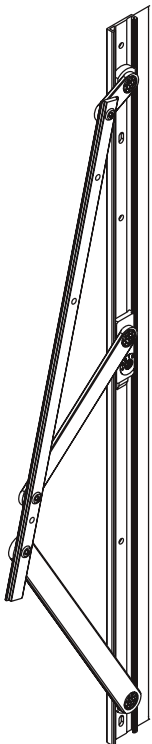

CONJUNTO DO BRAÇO - ALUMÍNIO - CAIXA 17 MM

CÓDIGO	COMP. A	FOLHA MÁXIMA		CARGA MÁXIMA
		ALTURA	LARGURA	
BRA588	342	Min: 588 Min: 600	1500	22KG
BRA589	600	Min: 640 Min: 1000	1500	35KG
BRA590	951	Min: 990 Min: 1200	1500	42KG
BRA591	1200	Min: 1240 Min: 1500	1500	74KG

Obs: Verificar no catálogo do fornecedor as referências para instalação dos braços

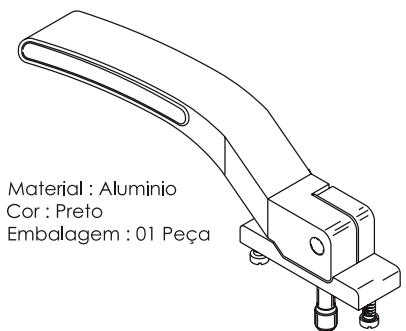

Material : Alumínio
Cor : Preto
Embalagem : 01 Peça

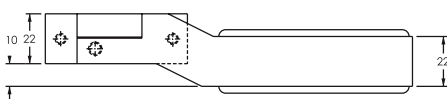
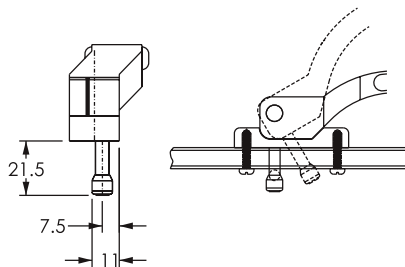
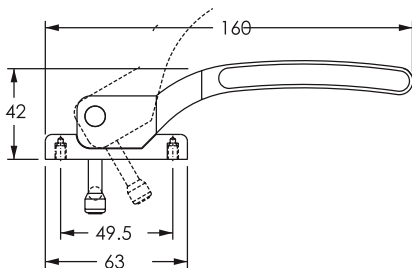

CÓDIGO	DESCRIÇÃO
FEC450	FECHE ARTICULADO ALUMINIO PRETO (DIREITO)
FEC451	FECHE ARTICULADO ALUMINIO PRETO (ESQUERDO)

NOTA: Verificar nos fornecedores homologados outros modelos de fechos

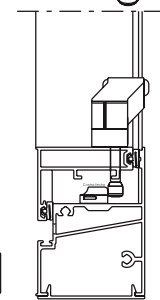

DETALHE DE USO

Projetos, perfis, componentes, códigos e sistemas estão sujeitos a alteração sem prévio aviso.

FECHE MULTI-PONTO

ESQUEMA DE TRAVAMENTO JANELA MAXIM-AR

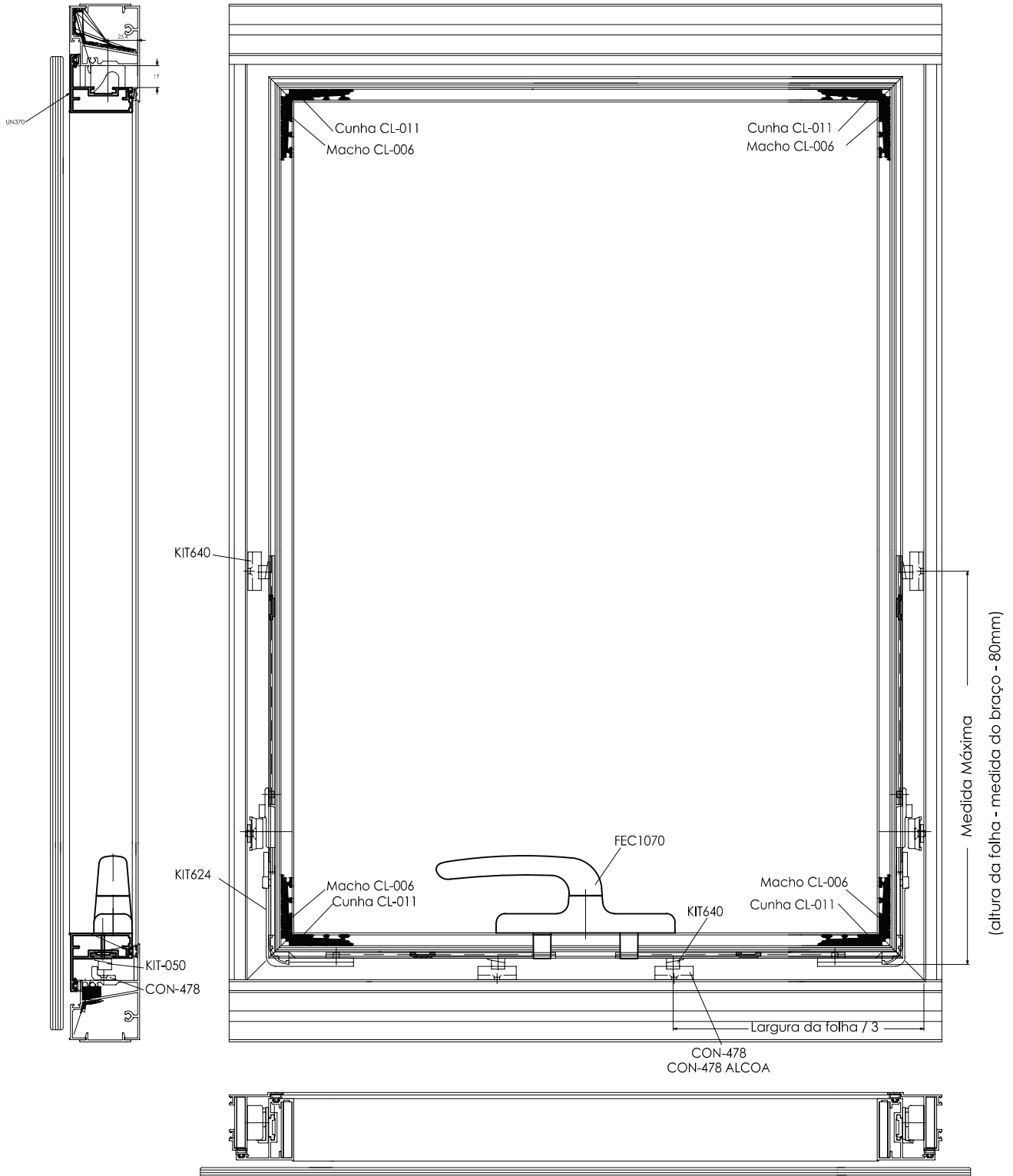

Projetos, perfis, componentes, códigos e sistemas estão sujeitos a alteração sem prévio aviso.

FECHO PERIMETRAL

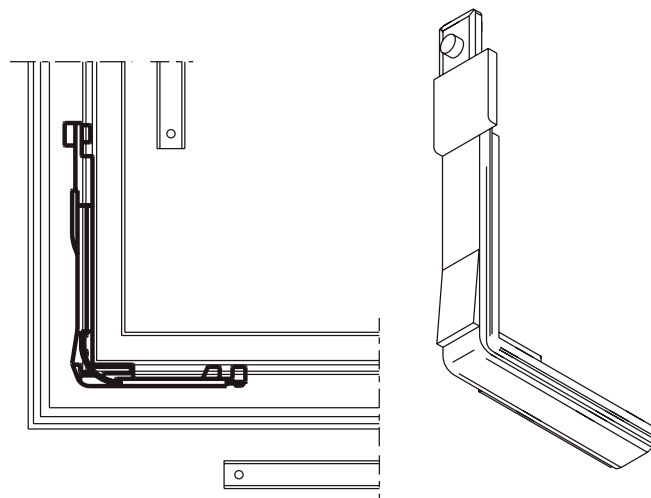
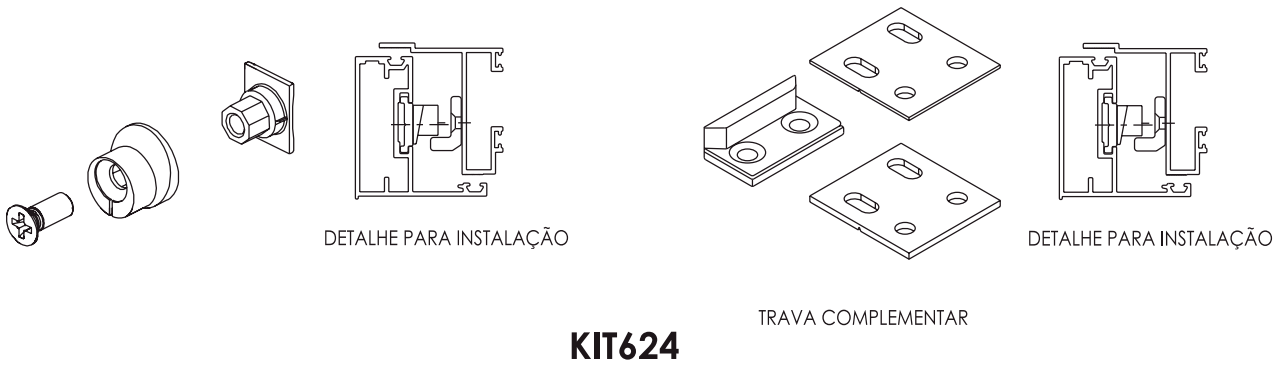
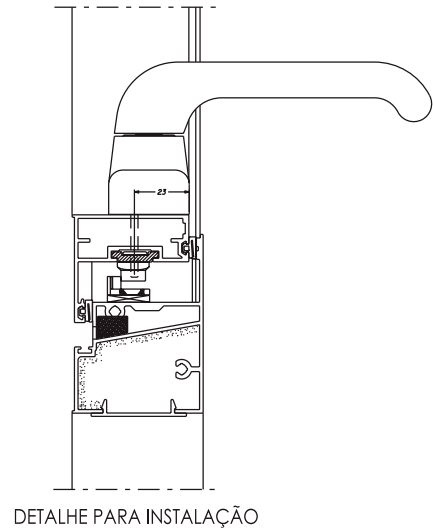
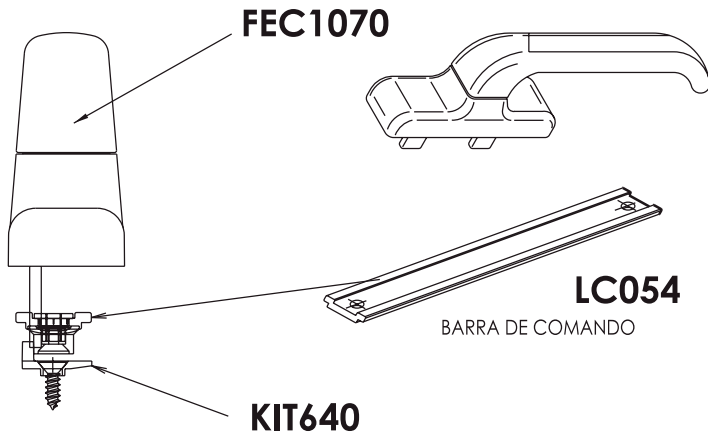

Projetos, perfis, componentes, códigos e sistemas estão sujeitos a alteração sem prévio aviso.

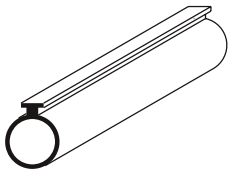

GUA007

Guarnição da Pingadeira

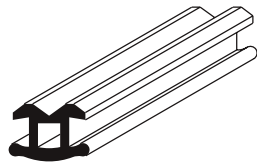

GUA350

Guarnição do Marco

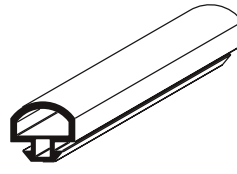

GUA441

Guarnição da Folha



TAR003

Tarucel Ø 10 mm



GUA328

Guarnição da Coluna

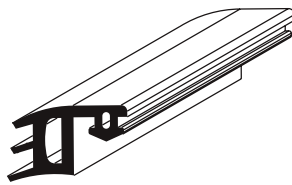

GUA381

Guarnição das travessas

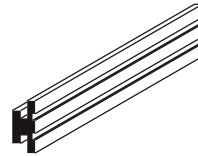

NYL039

Deslizante da travessa

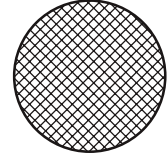

TAR006

Tarucel Ø 20 mm

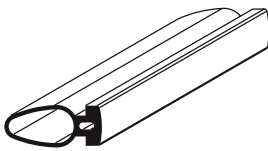

GUA383

Guarnição da Coluna

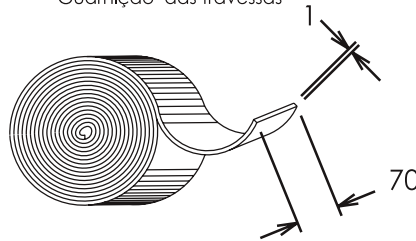

GUA384

Guarnição das Juntas
Borracha de Silicone

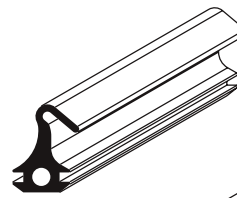

GUA438

Guarnição Superior
Folhas Max

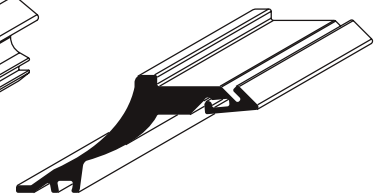

GUA443

Guarnição em Concreto

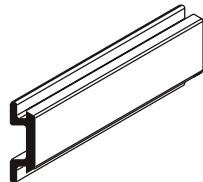

GUA349

Guarnição da Travessa

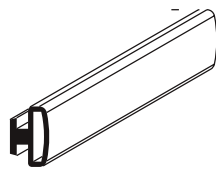

GUA389

Guarnição da Travessa
Telescópica

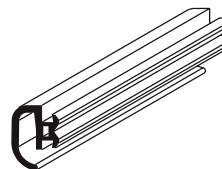

GUA410

Guarnição do Marco

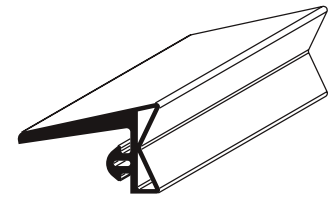

GUA320

Guarnição de cm

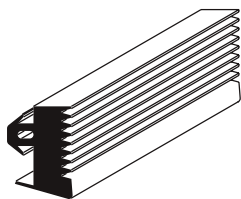

GUA387

Vidro de 8 mm

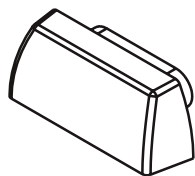

NYL490

Dreno

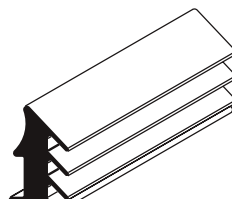

GUA388

Vidro de 8 mm

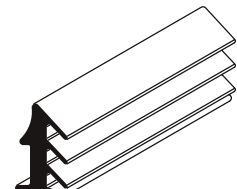

GUA390

Vidro de 9 mm



GUA442

Pingadeira

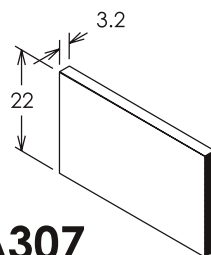

GUA307

FITA VEDANTE DE ESPUMA DE PVC- CELULAS FECHADAS
ADESIVA EM UMA DAS FACES

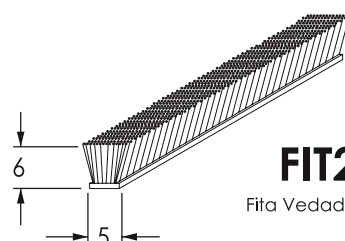

FIT206

Fita Vedadora 5x6mm

Projetos, perfis, componentes, códigos e sistemas estão sujeitos a alteração sem prévio aviso.

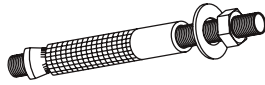

CHU794

CHUMBADOR C/PORCA,
ARRUELA E PRISIONEIRO - 9,5 mm x 120 mm

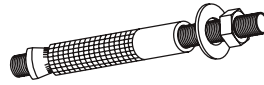

CHU795

CHUMBADOR C/PORCA,
ARRUELA E PRISIONEIRO - 9,5 mm x 80 mm

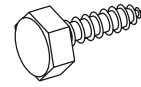

PAR063

Paraf. AA C.SEXT 4,8 x 19
AÇO INOX NATURAL

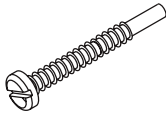

PAR428

Paraf. AA CP 4,8 x 32
AÇO INOX NATURAL

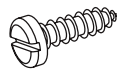

PAR437

PARAF. AA CP 3,5 x 9,5
AÇO INOX NATURAL

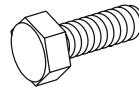

PAR670

PARAF. SEXT. 3/8" x 2"
AÇO INOX NATURAL

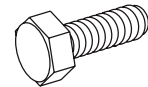

PAR1085

PARAF. SEXT. M10 x 25
AÇO INOX NATURAL

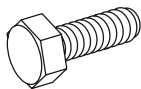

PAR1084

PARAF. SEXT. M10 x 35
AÇO INOX NATURAL

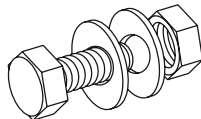

PAR1053

PARAF. SEXT. 3/8" x 1.1/4"
PORCA E 2 ARRUELAS
AÇO INOX NATURAL

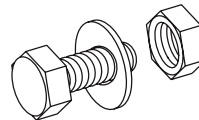

PAR1059

PARAF. SEXT. 1/4" x 5/8"
1 PORCA E ARRUELAS
AÇO INOX NATURAL

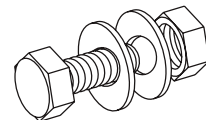

PAR1061

PARAF. SEXT. 3/16" x 1/2"
PORCA E 2 ARRUELAS
AÇO INOX NATURAL

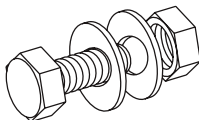

PAR1071

PARAF. SEXT. 3/16" x 1.3/4"
PORCA E 2 ARRUELAS
AÇO INOX NATURAL

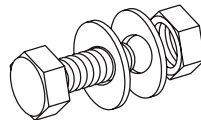

PAR1072

PARAF. SEXT. 3/16" x 1.1/2"
PORCA E 2 ARRUELAS
AÇO INOX NATURAL

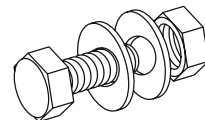

PAR1073

PARAF. SEXT. 3/8" x 1.3/4"
PORCA E 2 ARRUELAS
AÇO INOX NATURAL

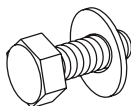

PAR1074

PARAF. SEXT. M6 x 20 C. ARRUELA
AÇO INOX NATURAL

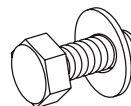

PAR1075

PARAF. SEXT. M4 x 16 C. ARRUELA
AÇO INOX NATURAL

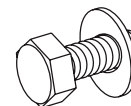

PAR1076

PARAF. SEXT. 3/8" x 1"
1 ARRUELA
AÇO INOX NATURAL



PAR1077

Paraf. CAB. CIL. C/SEXT. INT.-M6
AÇO INOX NATURAL

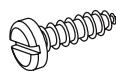

PAR691

PARAF. AA CP 4,8 x 13
AÇO INOX NATURAL

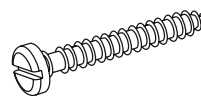

PAR1052

PARAF. AA CP 4,8 x 2"
AÇO INOX NATURAL

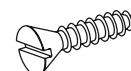

PAR698

PARAF. AA CX 4,2 x 25
AÇO INOX NATURAL

Projetos, perfis, componentes, códigos e sistemas estão sujeitos a alteração sem prévio aviso.

Ancoragem Superior - Entre Vãos

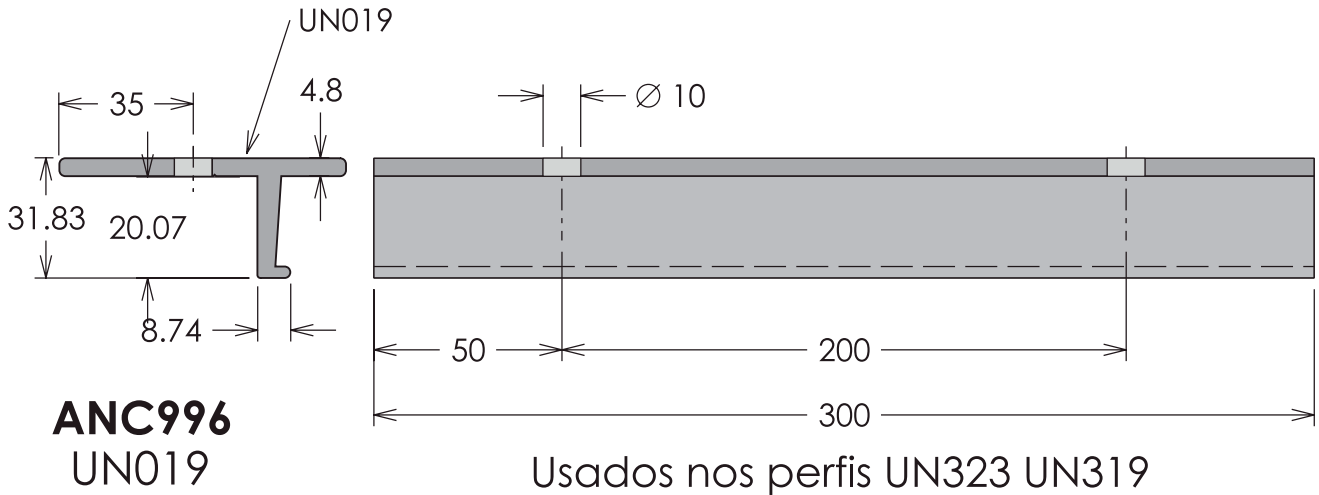

Ancoragem Superior Auxiliar

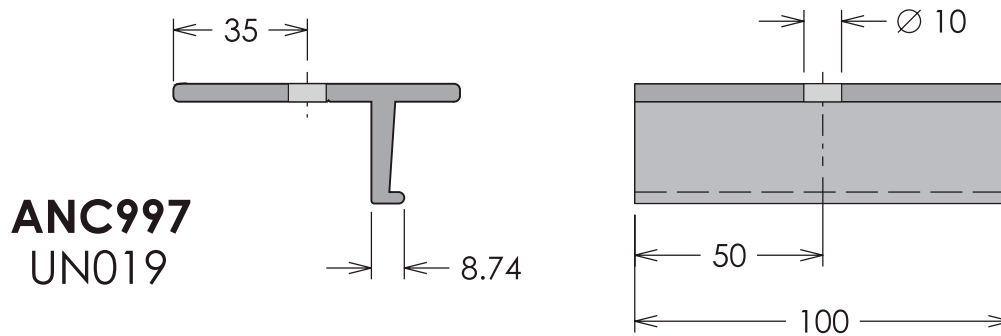

Fazer 1 peça de cada p/ teste

Vedador da Junção das Colunas

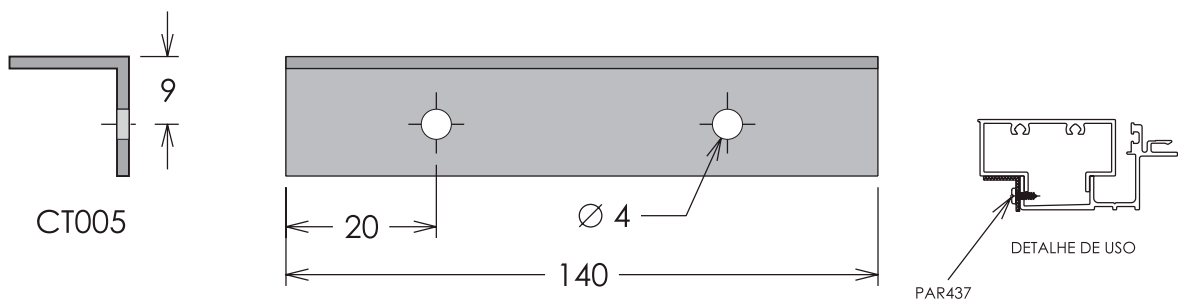

Ancoragem Superior - Entre Vãos

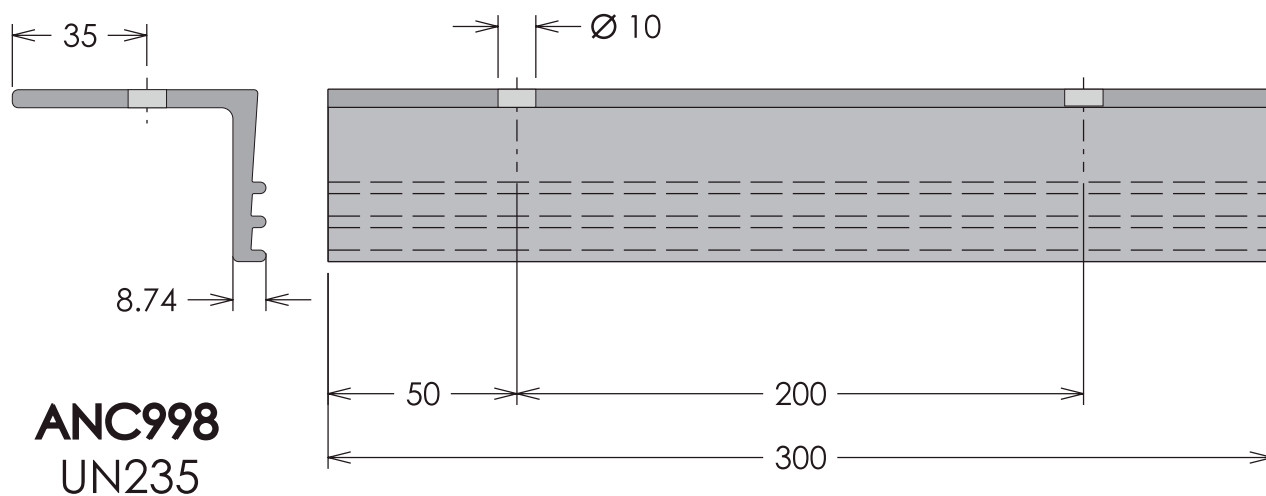

Usados nos perfis UN063

Ancoragem Superior Auxiliar

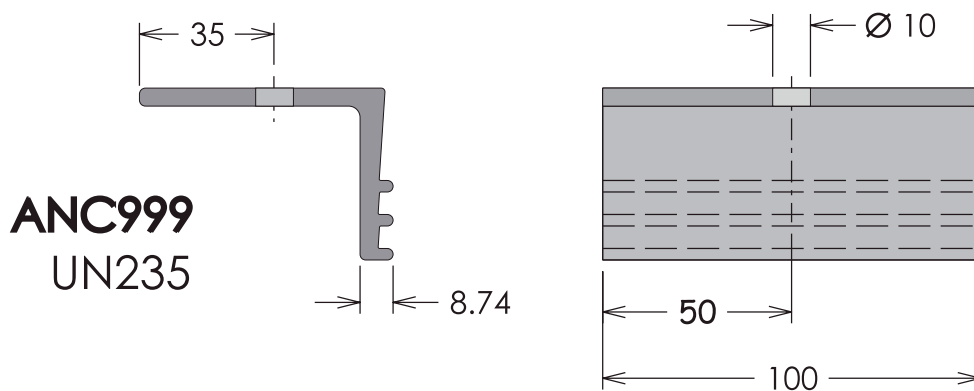

Ancoragem Superior - Entre Vãos

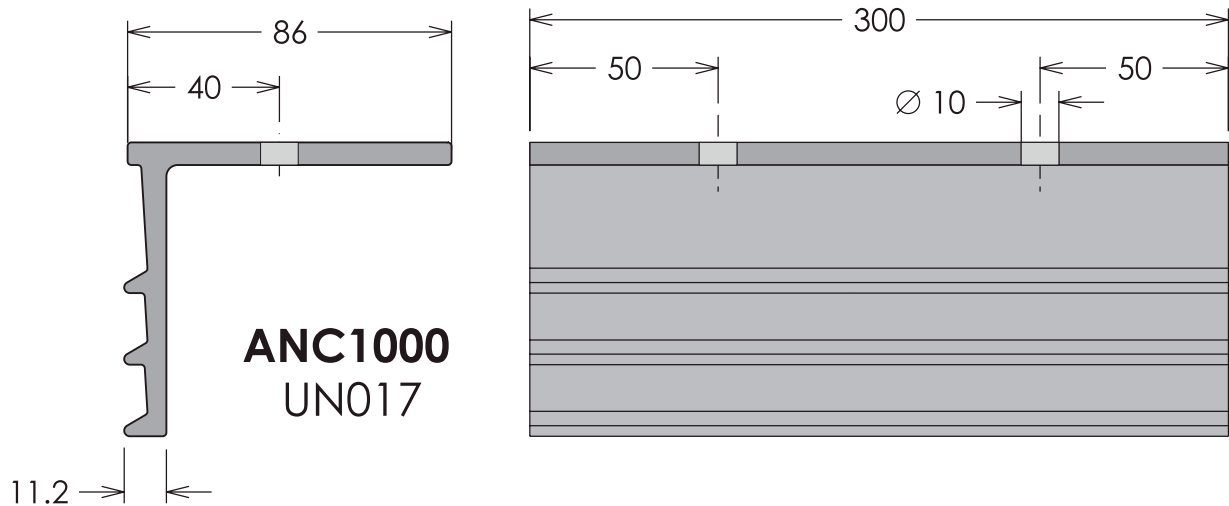

Usados nos perfis UN014 e UN336

Ancoragem Superior Auxiliar

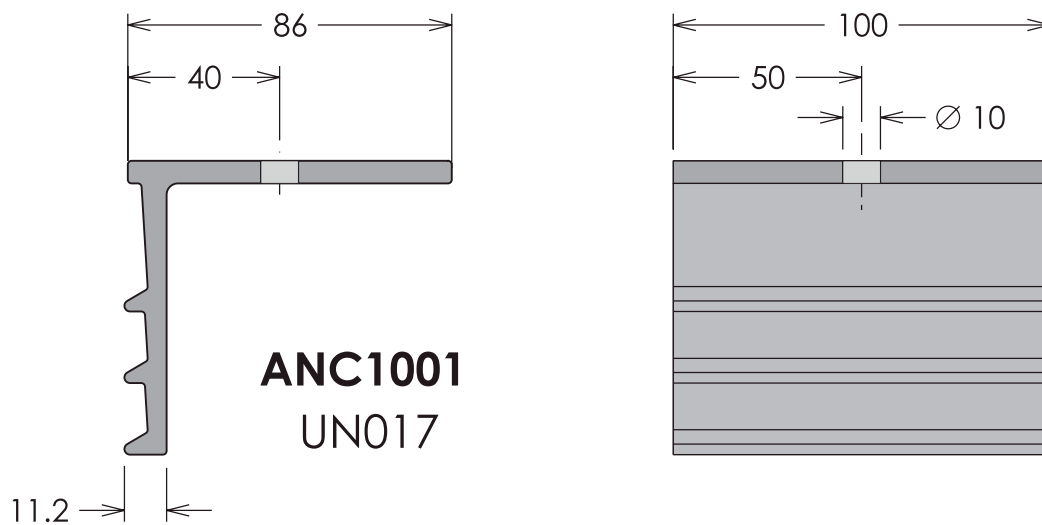

Ancoragem Superior - Entre Vãos

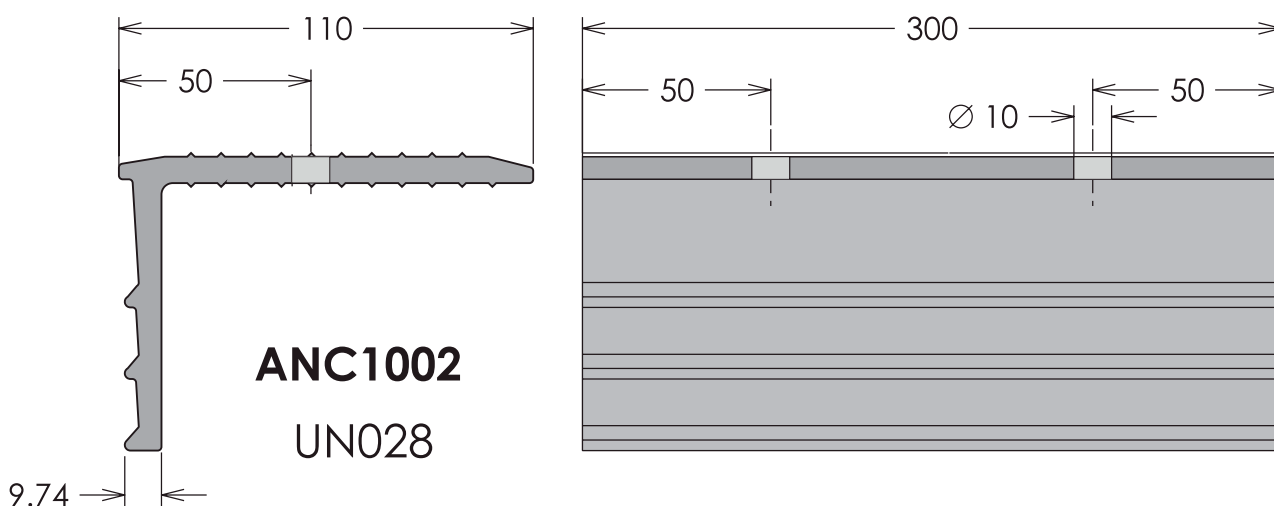

Usado no perfil UN331

Ancoragem Superior Auxiliar

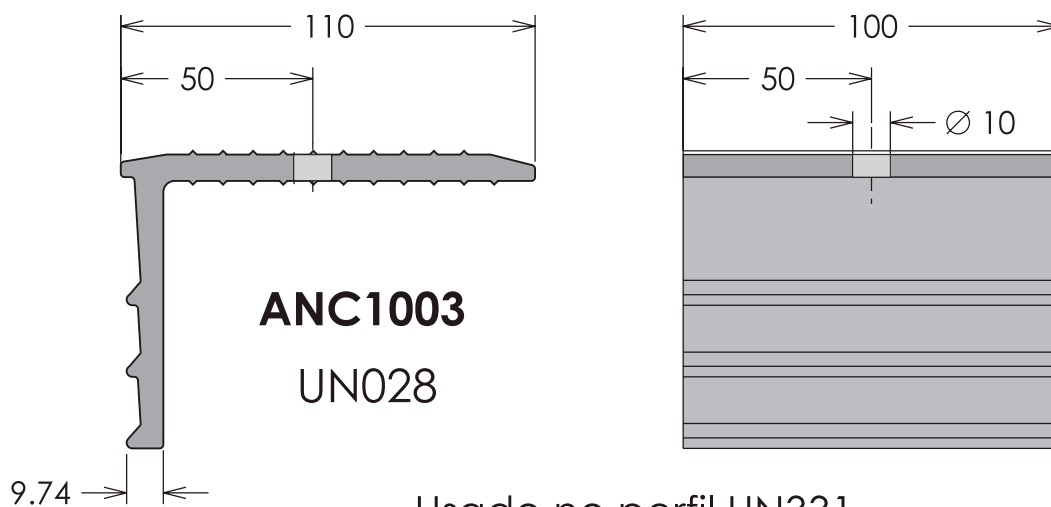

Usado no perfil UN331

Ancoragem Superior - Entre Vãos

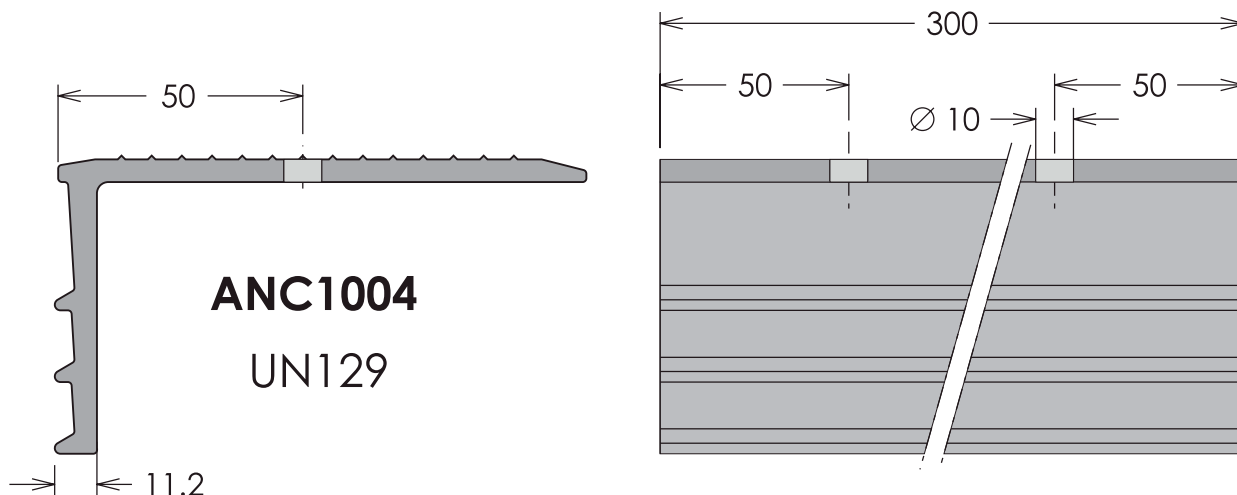

Usados nos perfis UN014 e UN336

Ancoragem Superior Auxiliar

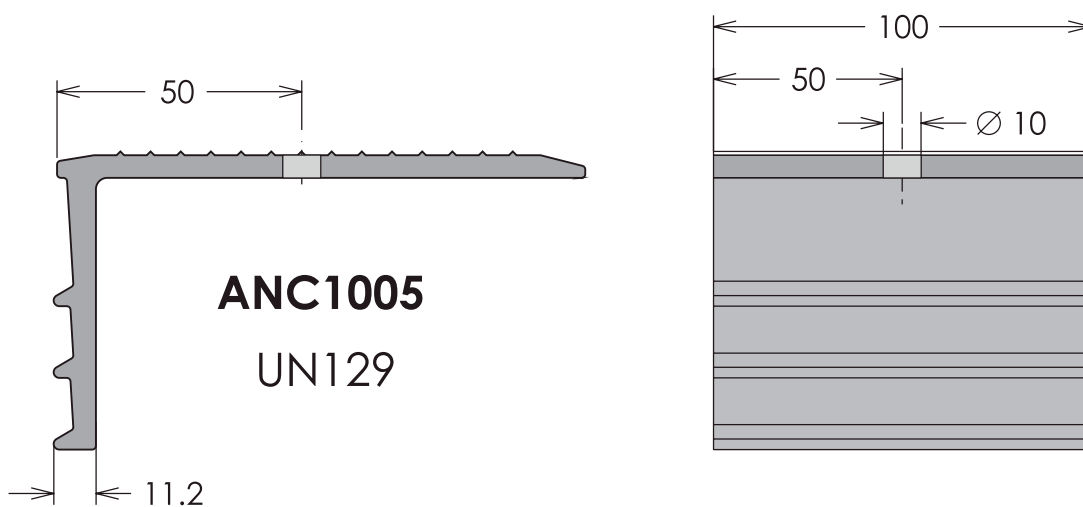

Usados nos perfis UN014 e UN336

Ancoragem Principal

ANC1006
UN048

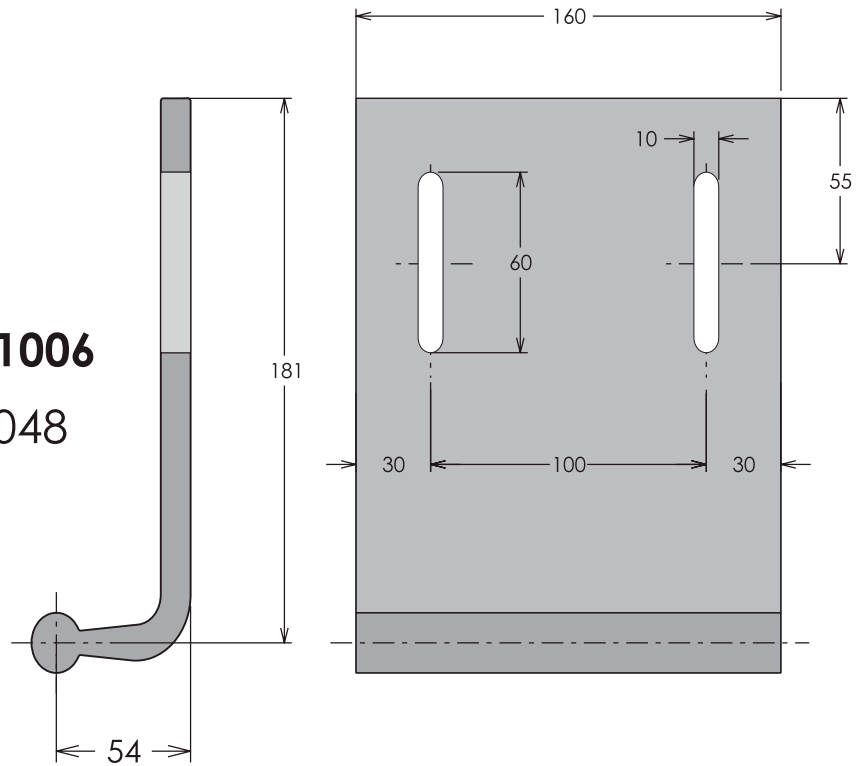

ANC983
UN098

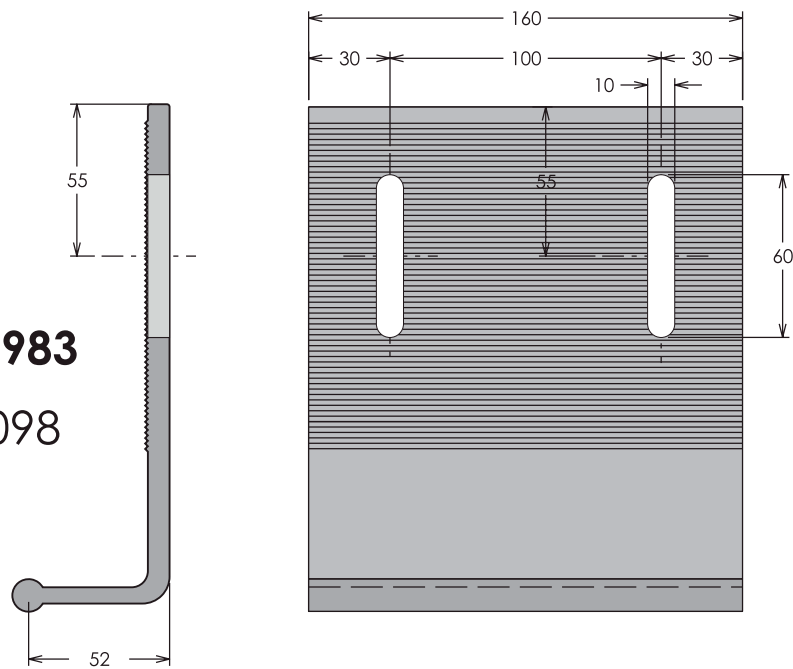

Ancoragem Frontal

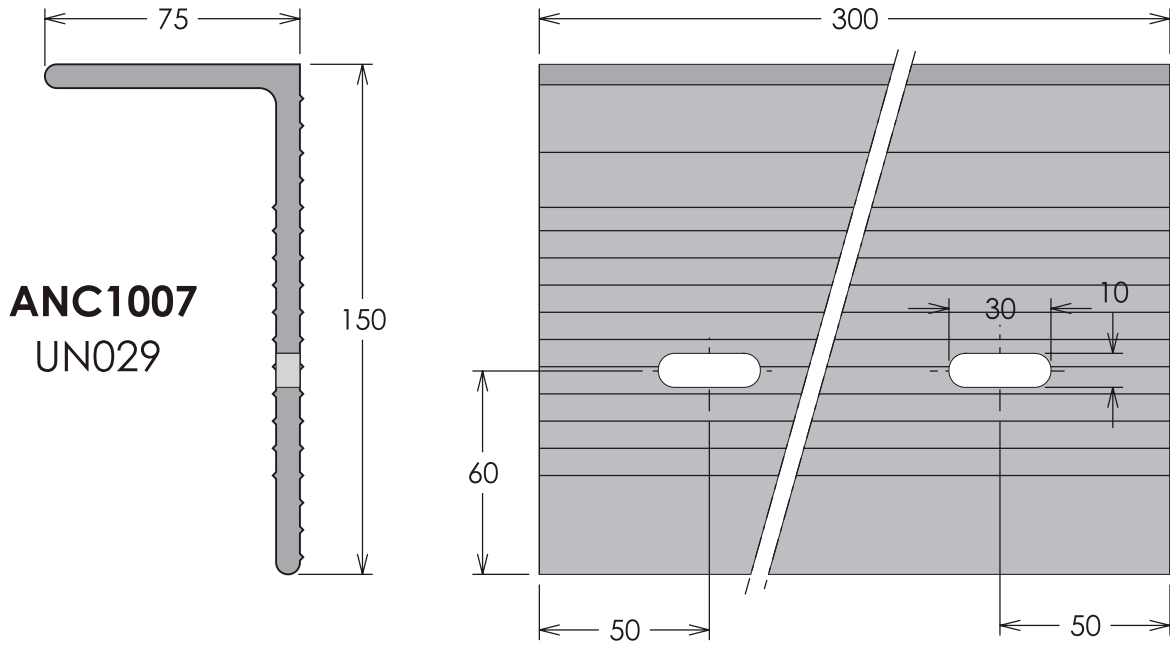

Ancoragem Auxiliar

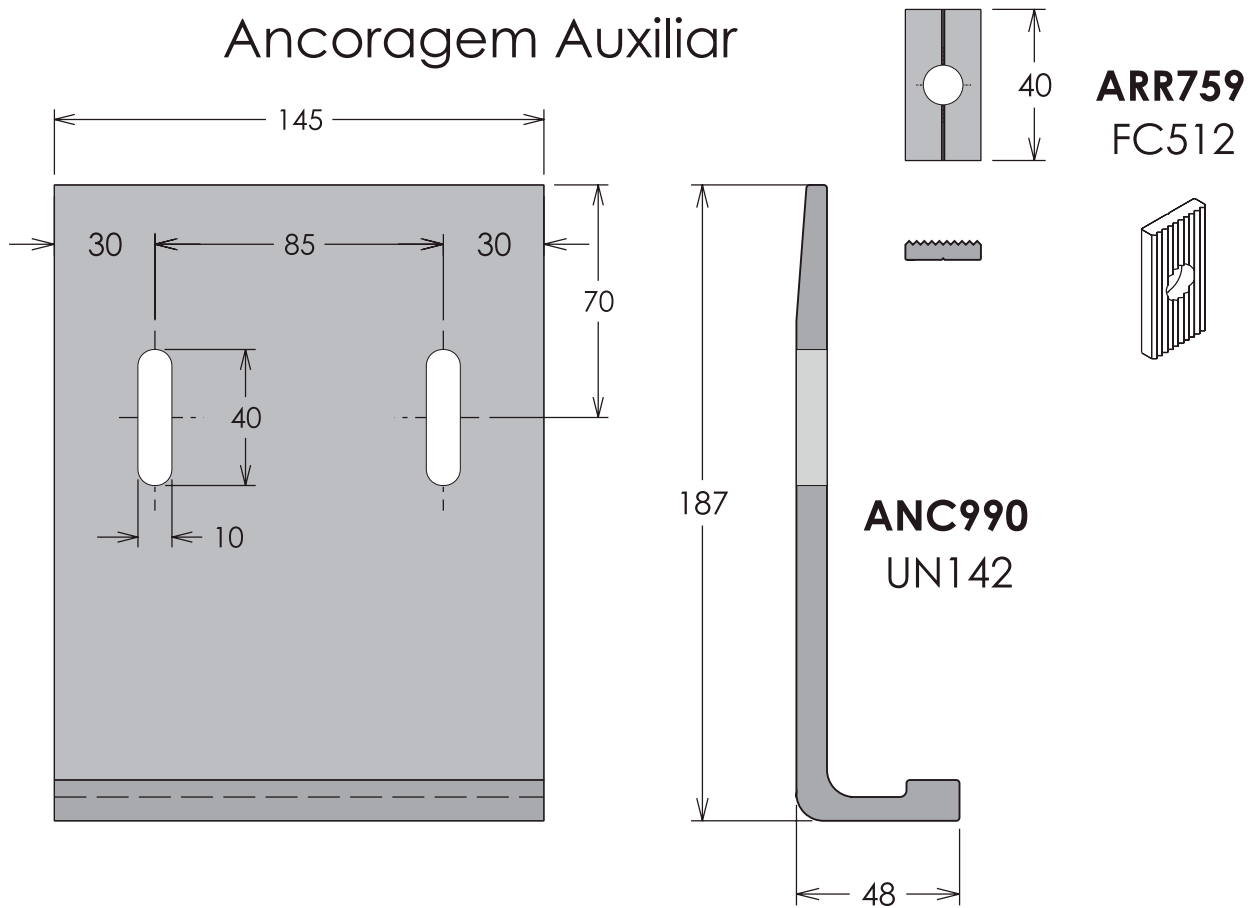

Ancoragem Principal

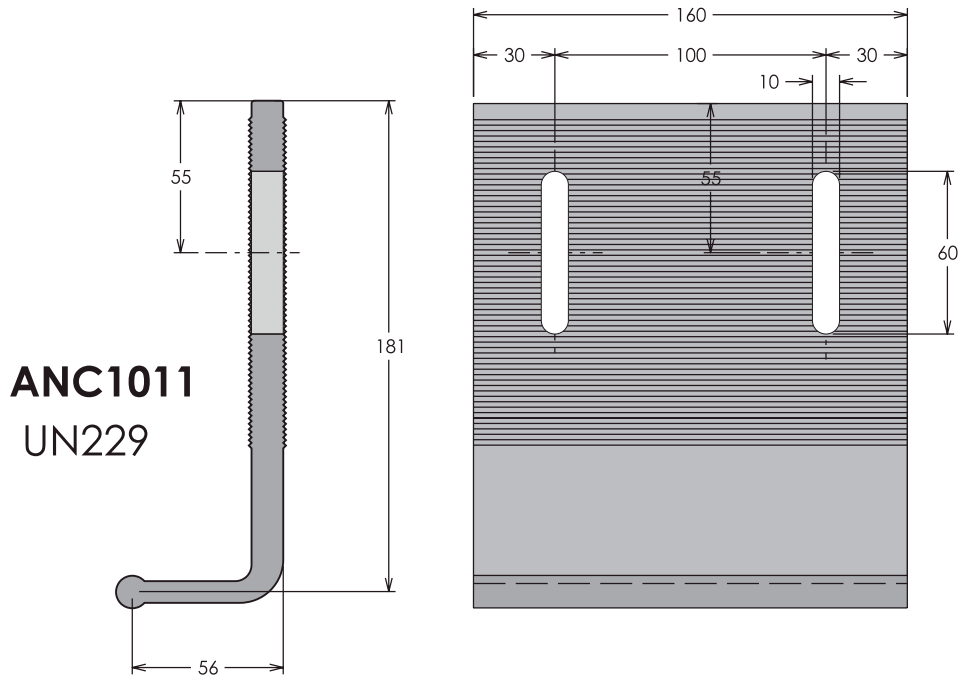

Ancoragem Frontal

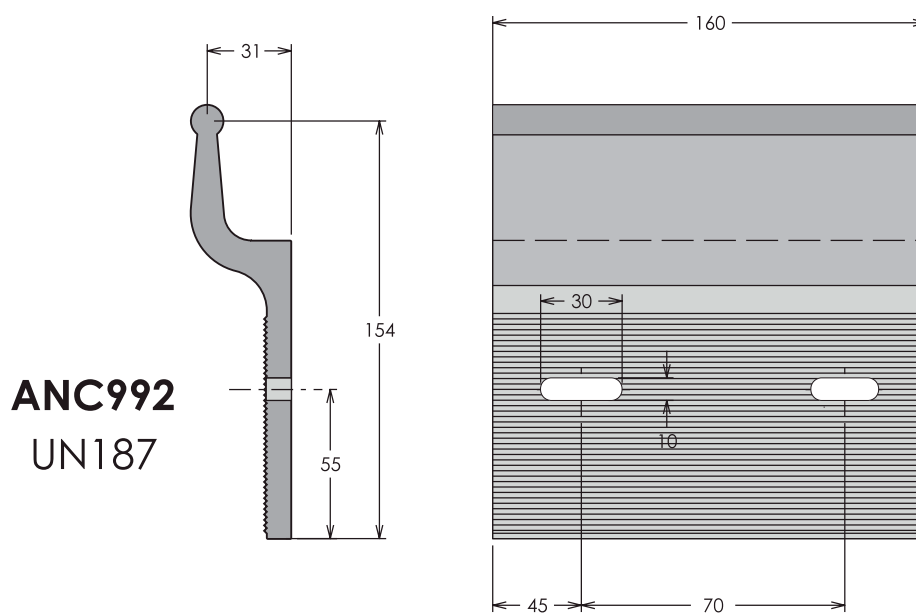

Ancoragem Principal

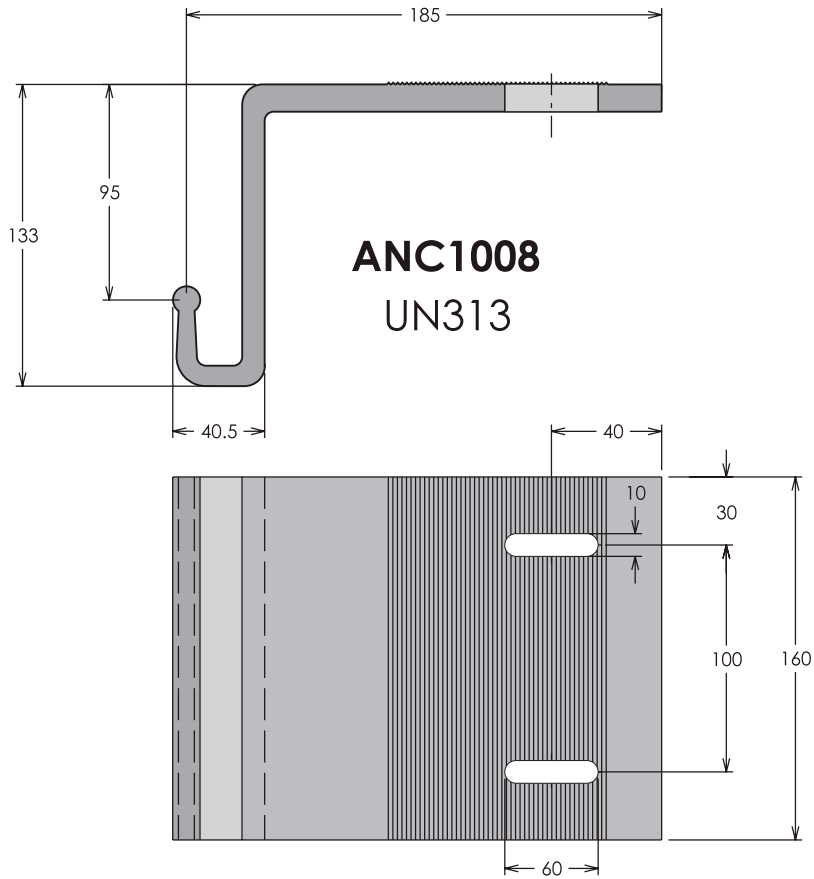

Ancoragem Frontal

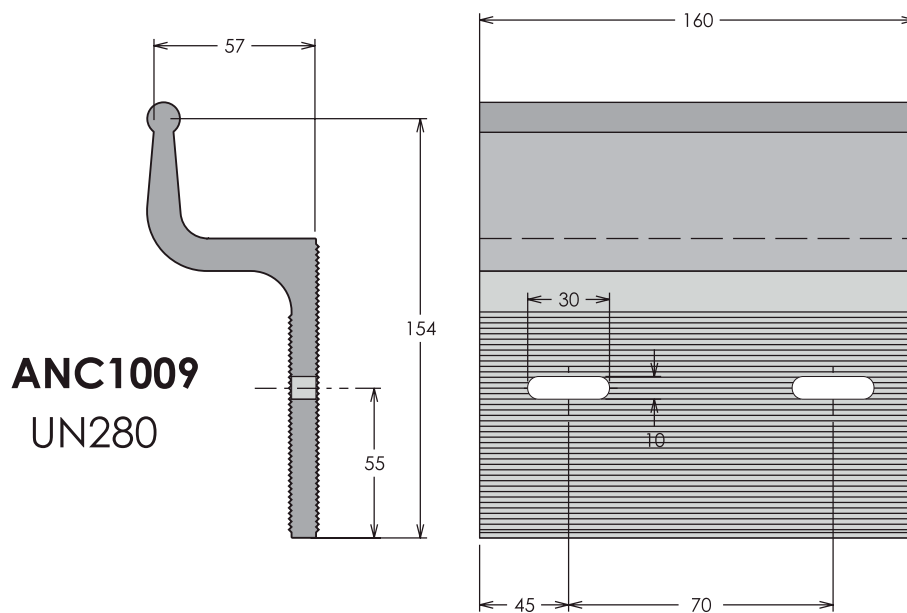

Ancoragem Telescópica

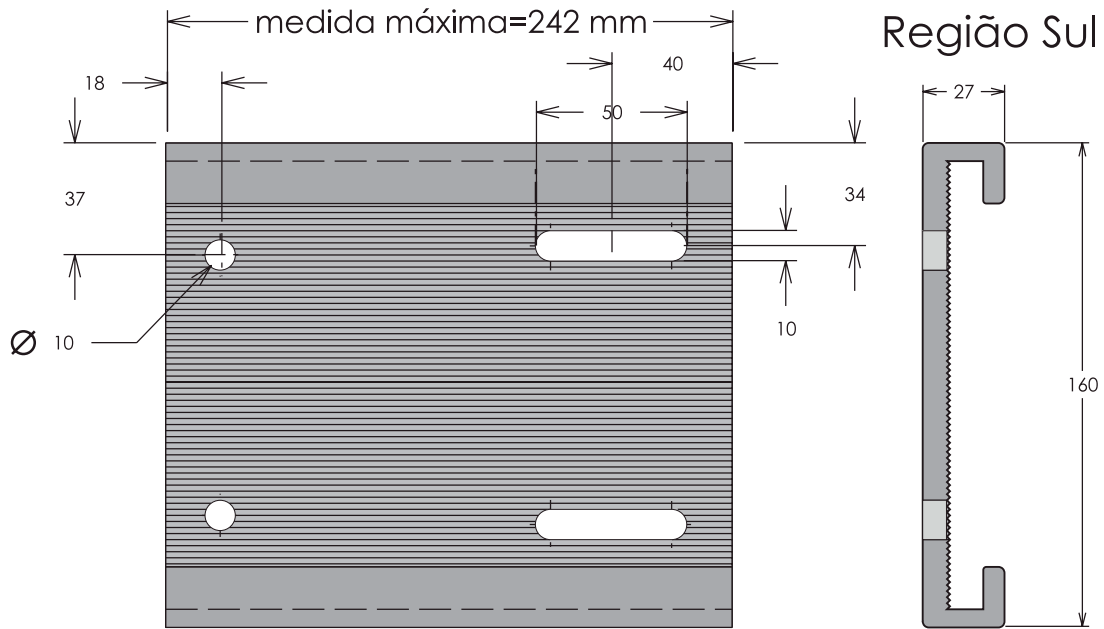

ANC991
UN254

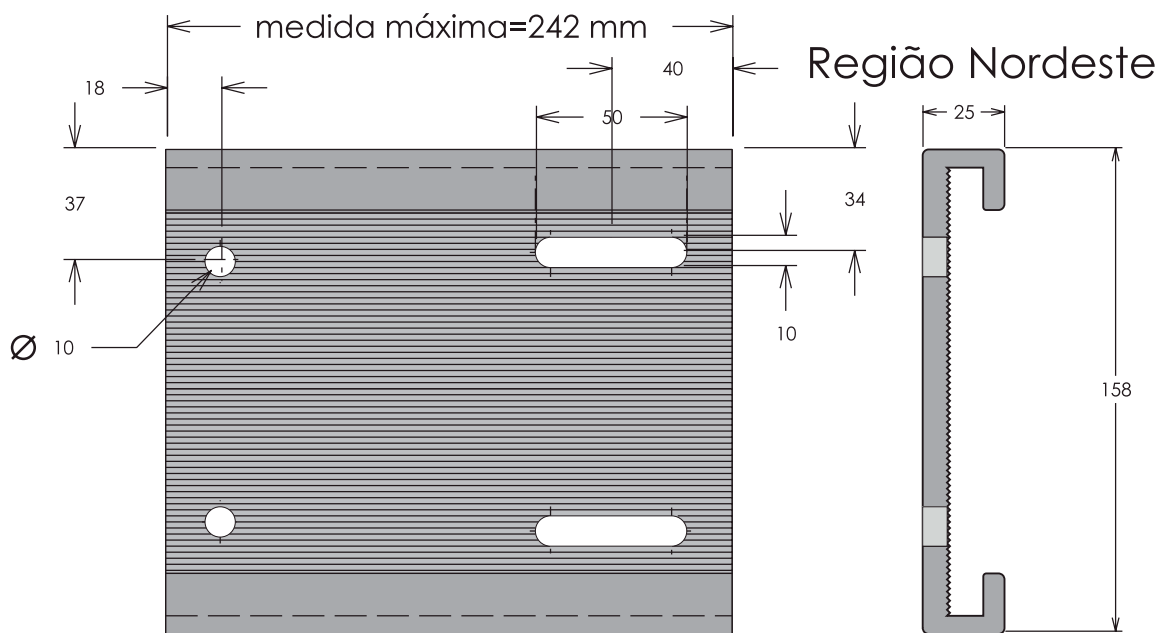

ANC995
UN256

Gancho Telescópico

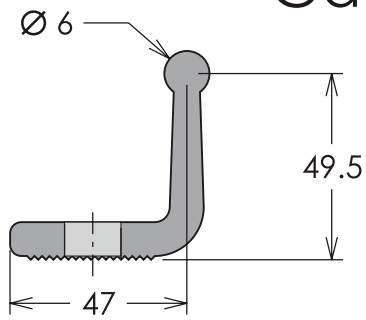

SUP711
UN255

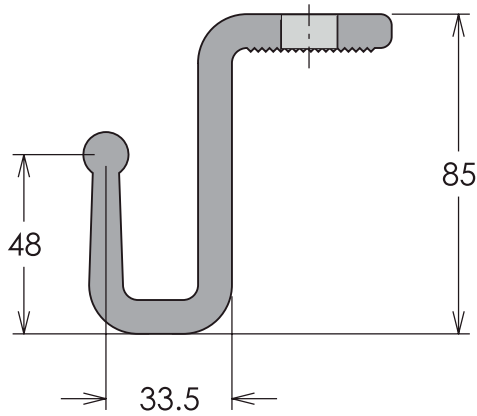
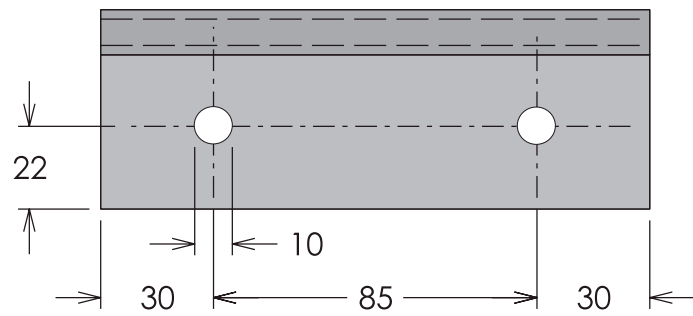
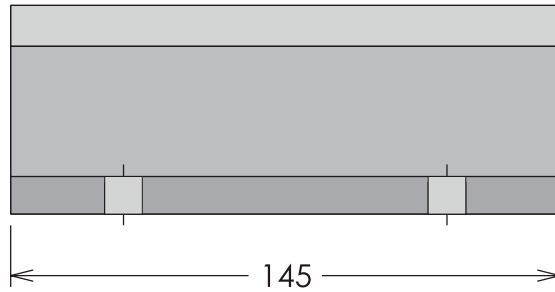

SUP698
UN267

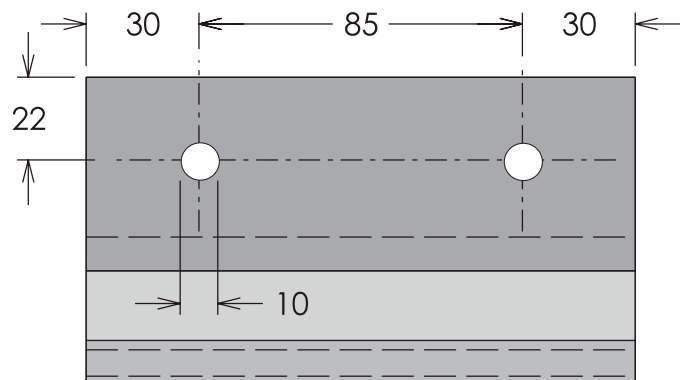
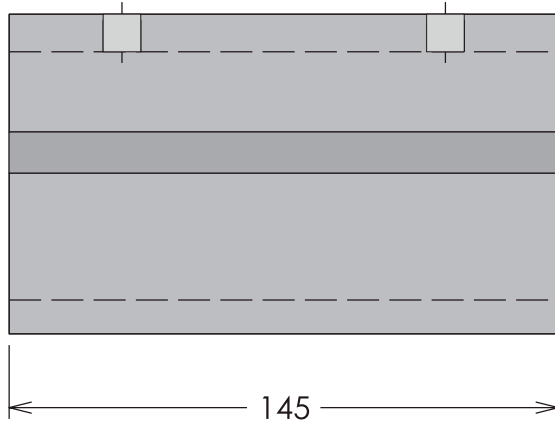

Ancoragem Telescópica Auxiliar

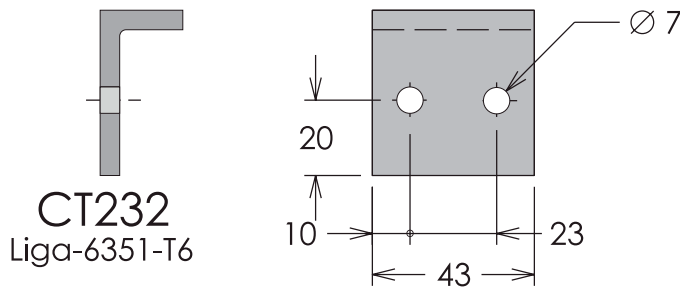
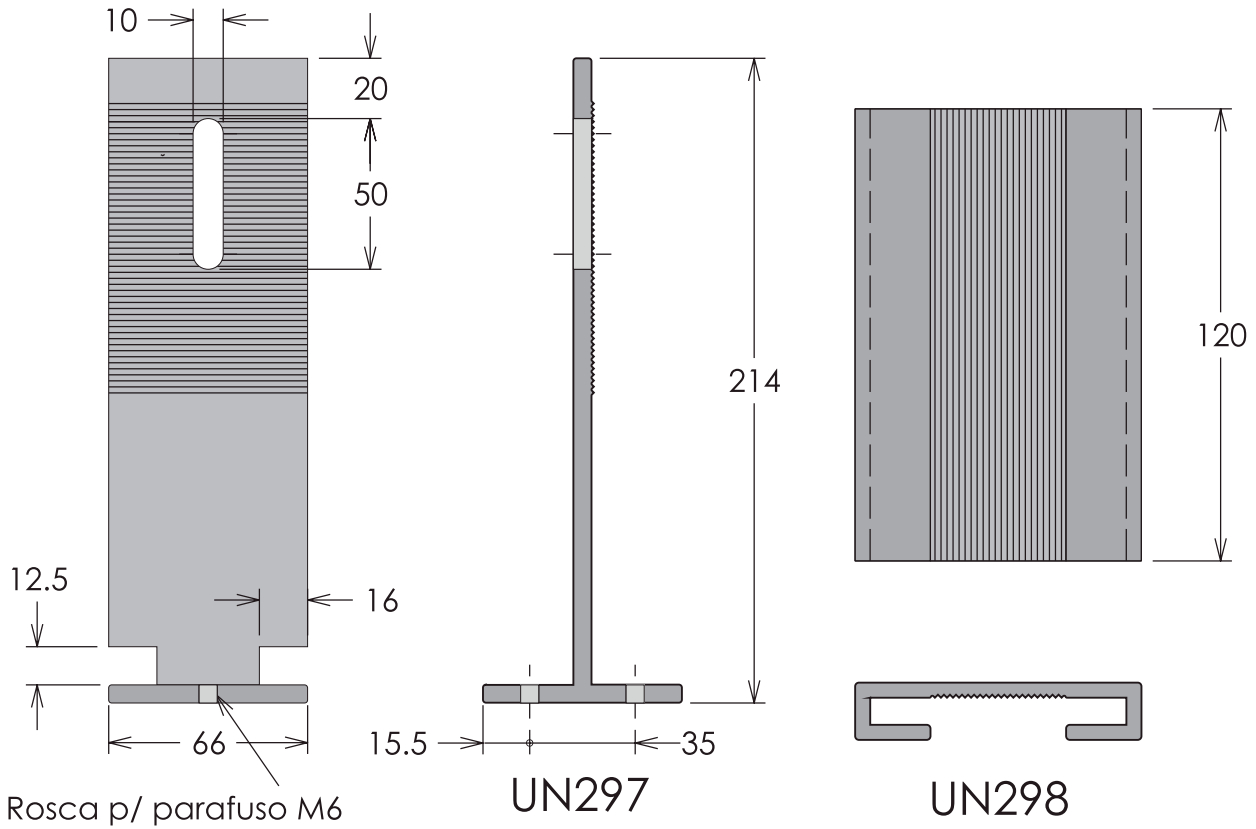

Componente fornecido sem parafusos

Duas peças p/ conjunto

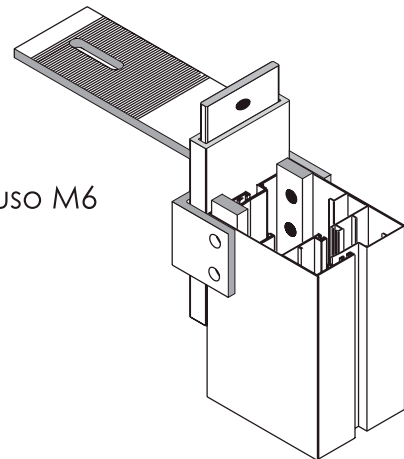
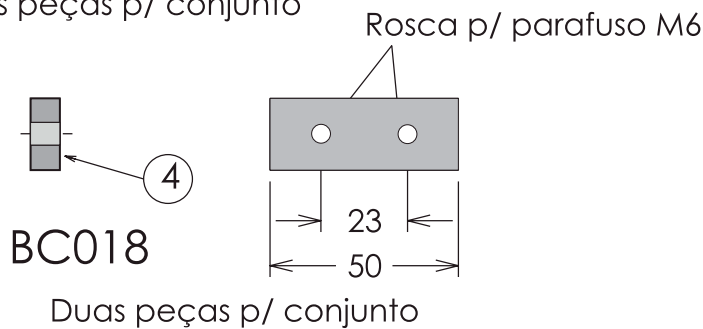

DETALHE DE USO

Anc. Telescópica Auxiliar-Canto
 Conjunto - ANC1022 - Para canto negativo

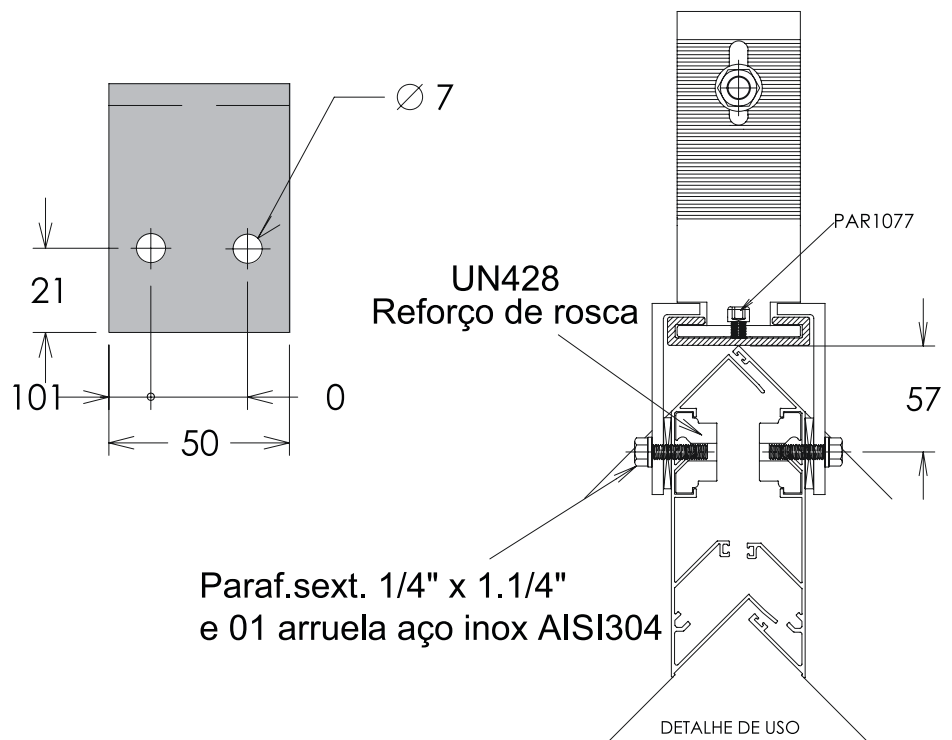
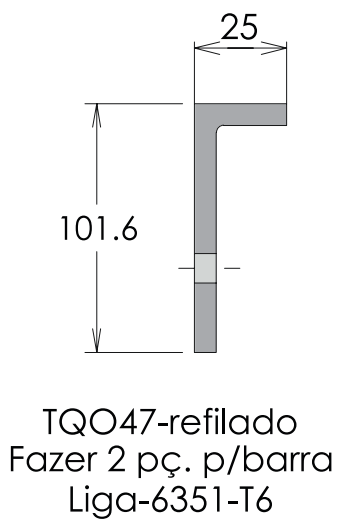
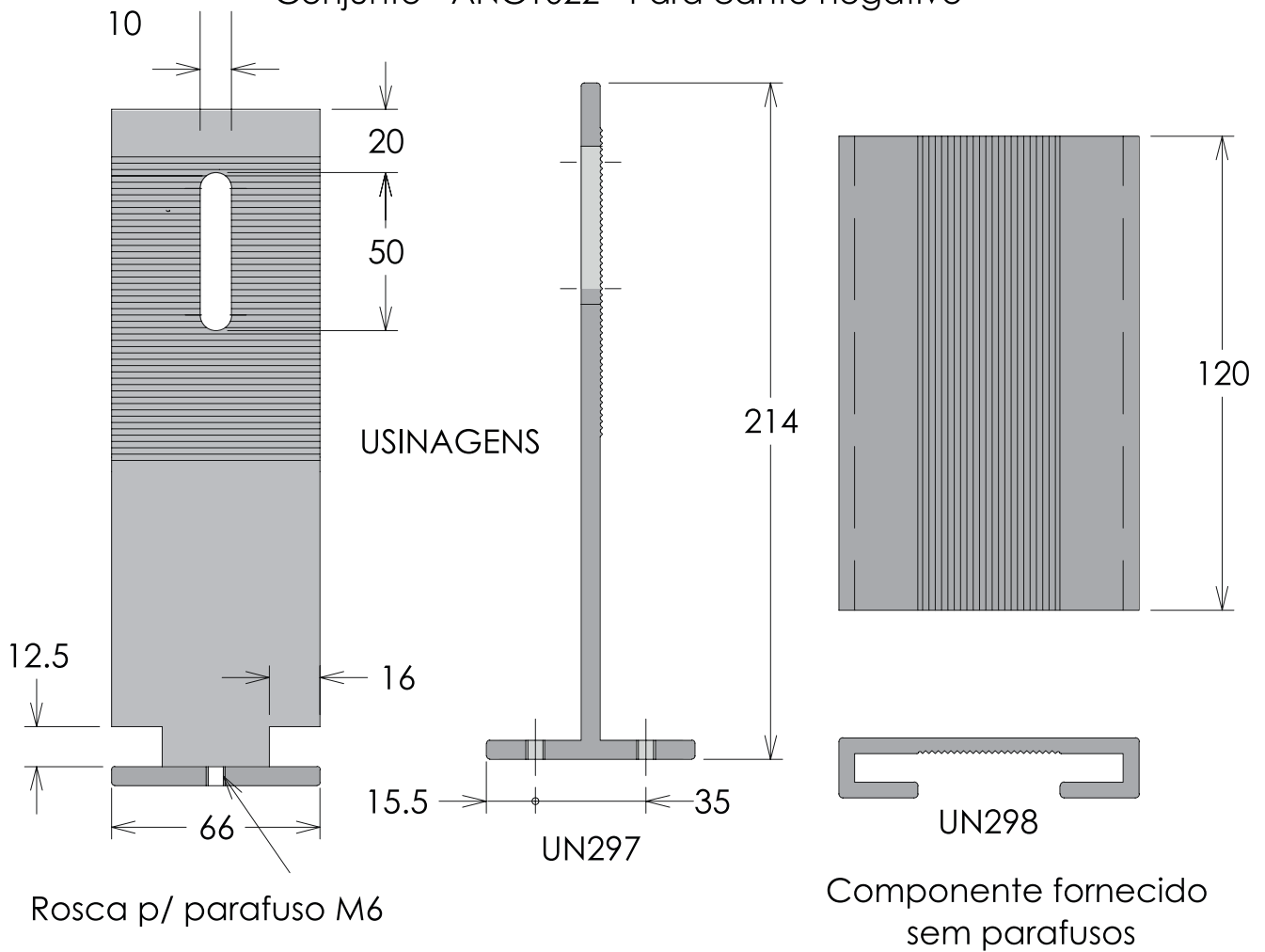

Anc. Telescópica Auxiliar-Canto
 Conjunto - ANC1021 - Para canto positivo

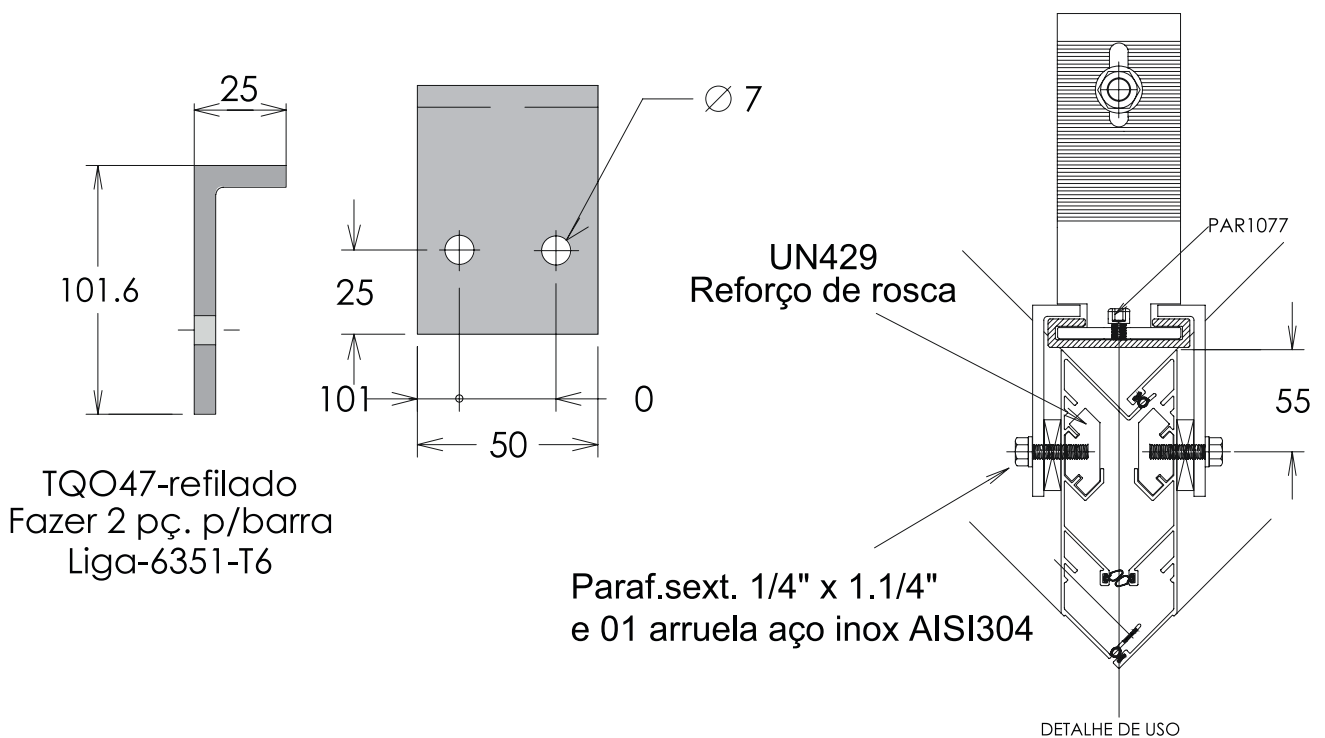
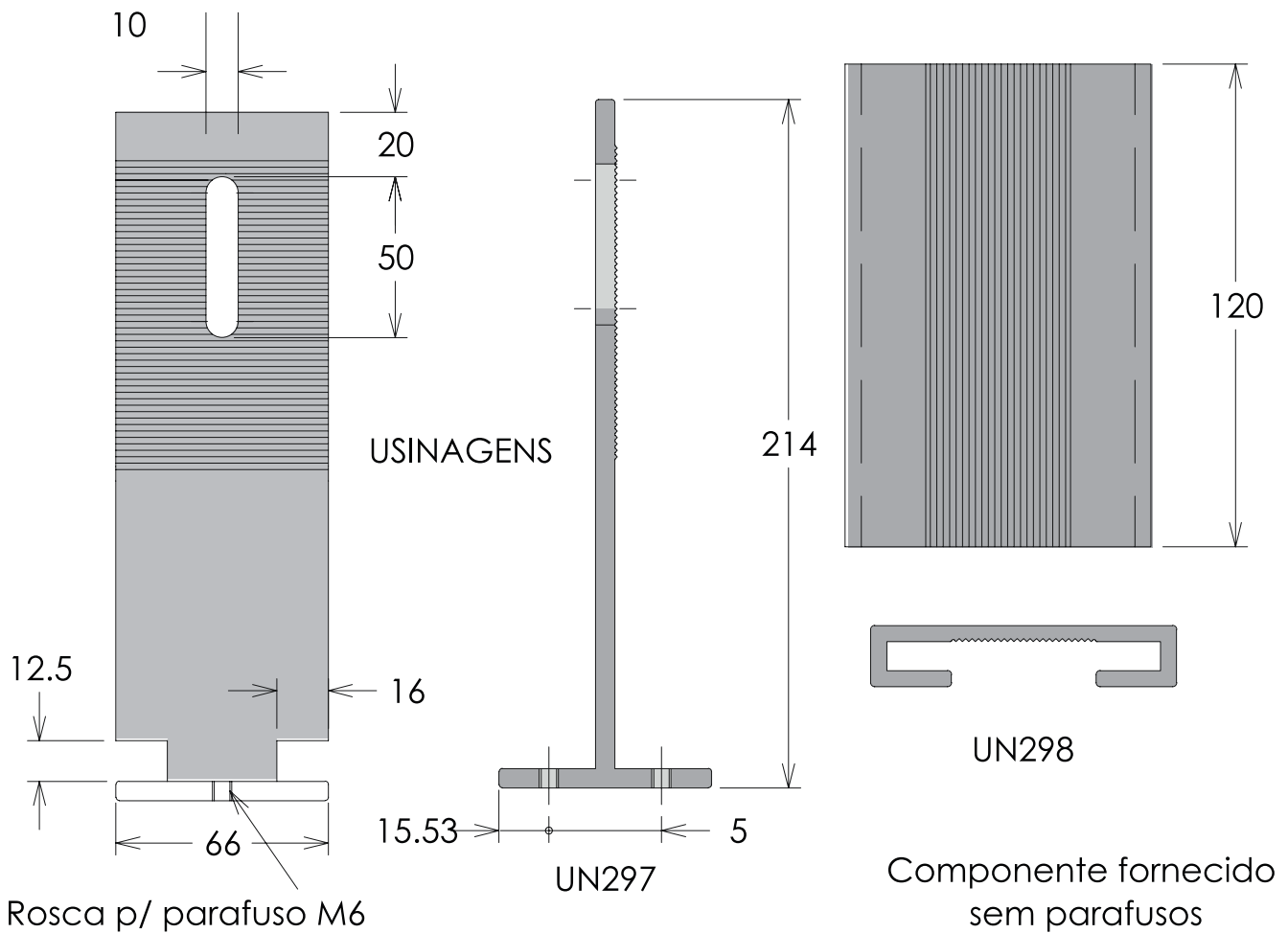

Canto Positivo

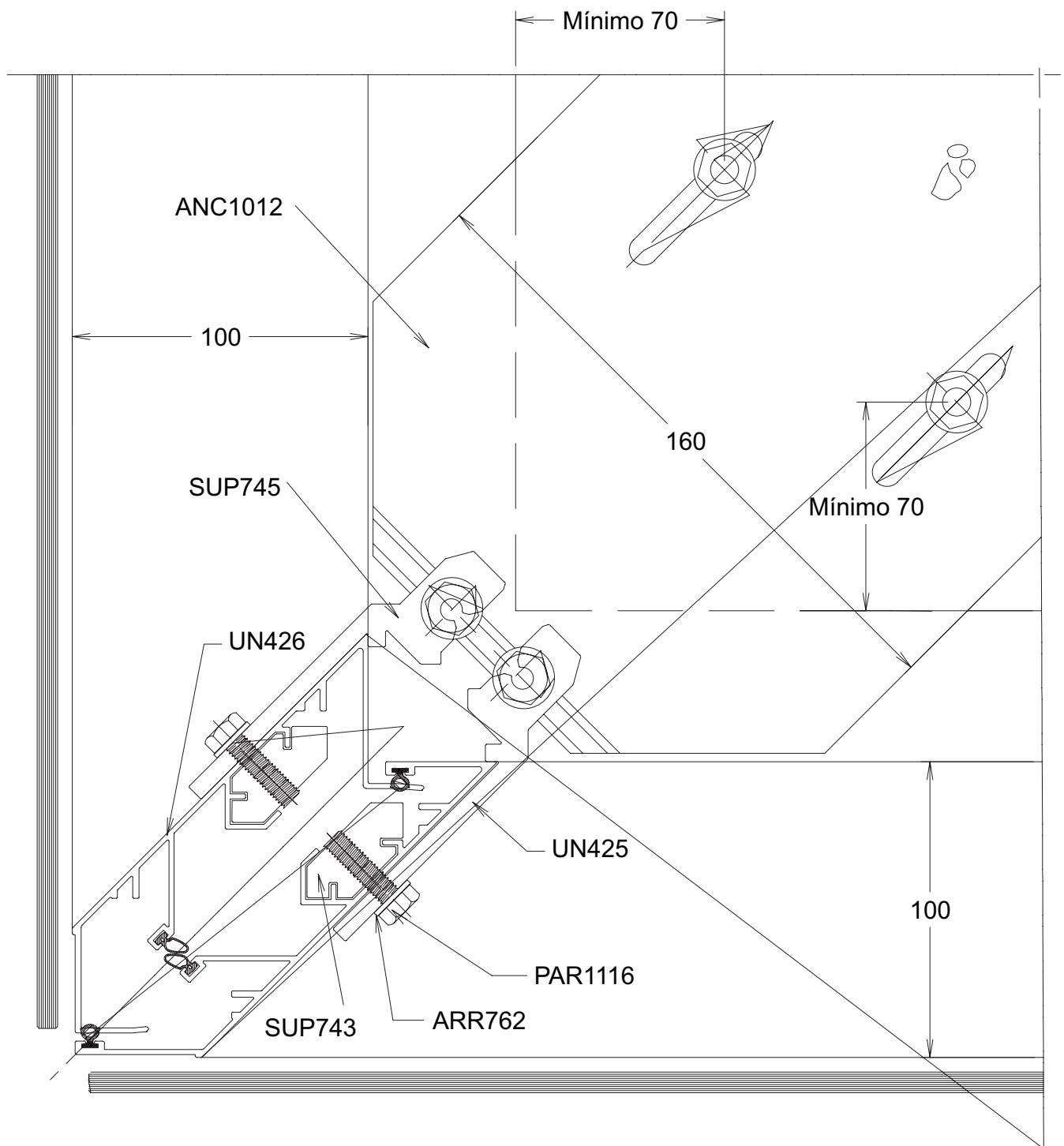

Ancoragem Principal de Canto POSITIVO

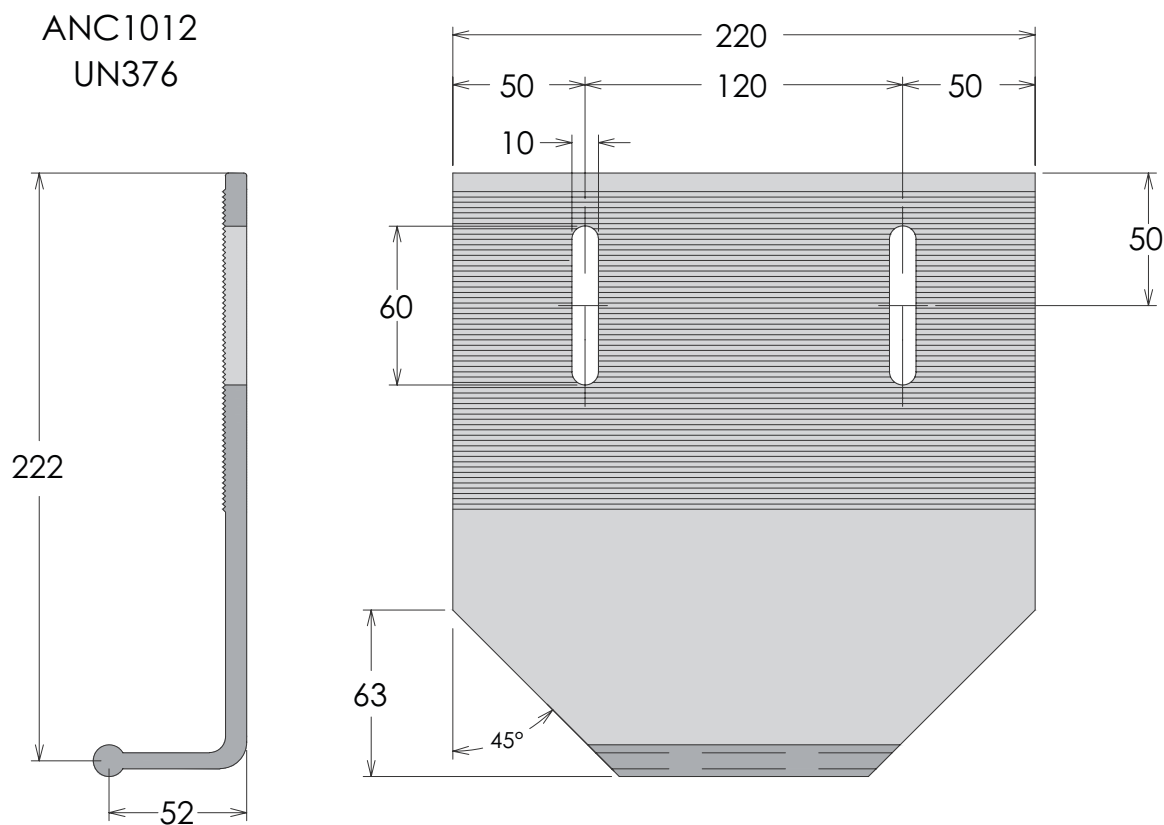

NOTA: Para o canto NEGATIVO, usar ANC983
(UN098)

Detalhe de uso

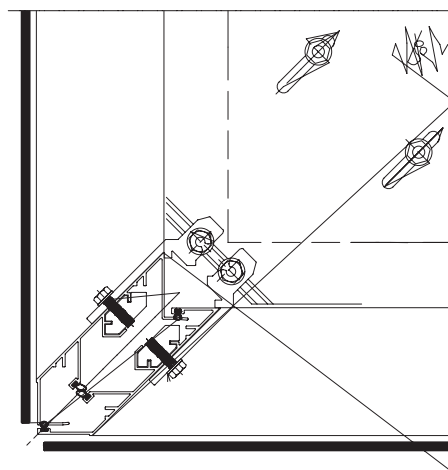

SUP749
 Suporte para colunas de canto negativo
 Coluna 80 mm
 UN377

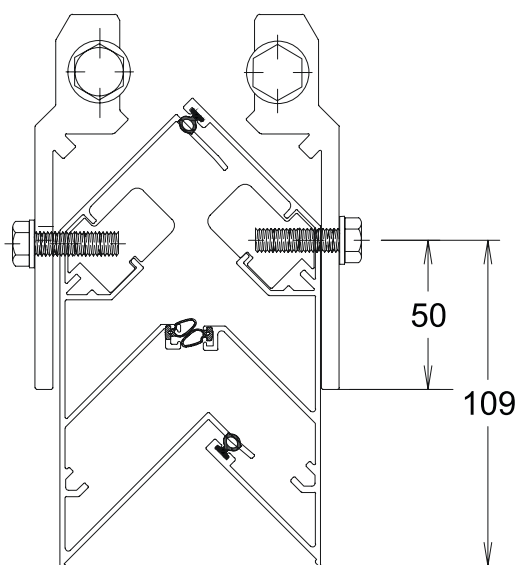
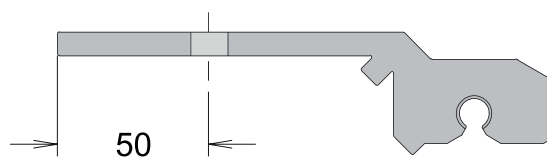
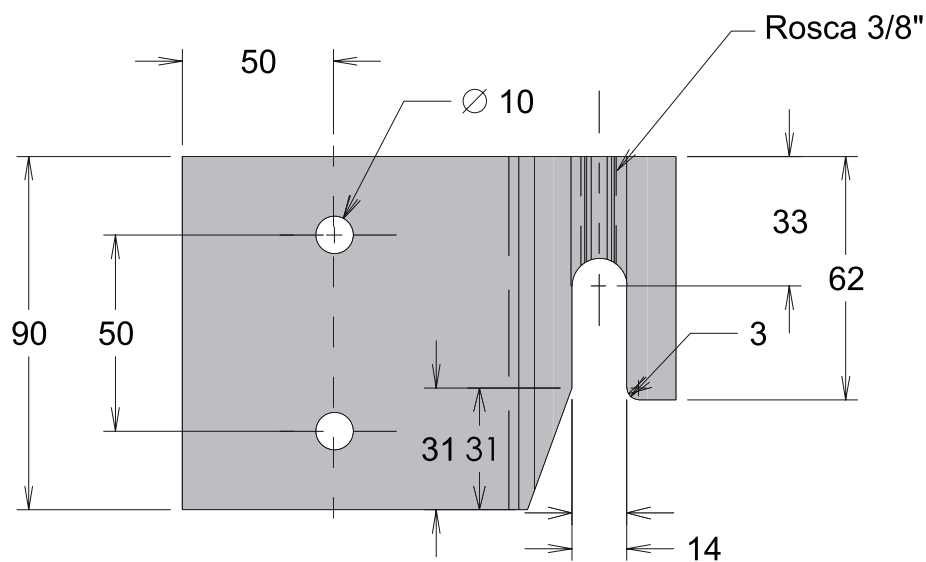

Detalhe de uso

SUP750

Suporte para colunas de canto positivo

Coluna 80 mm

UN377

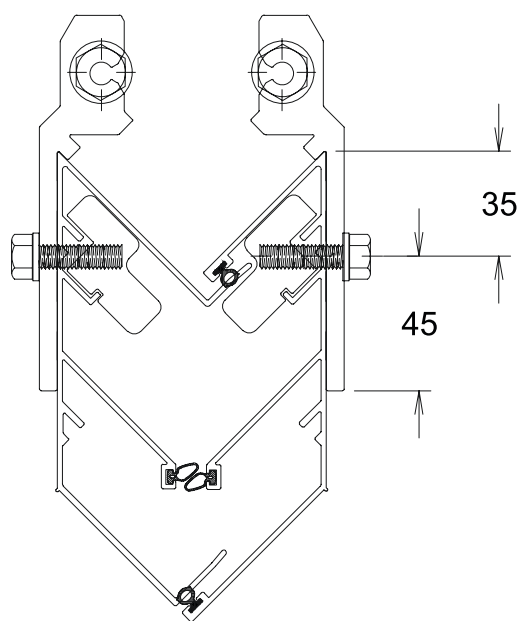
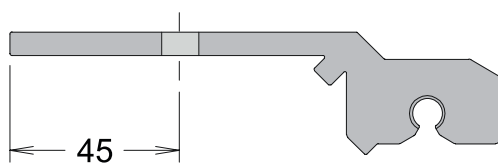
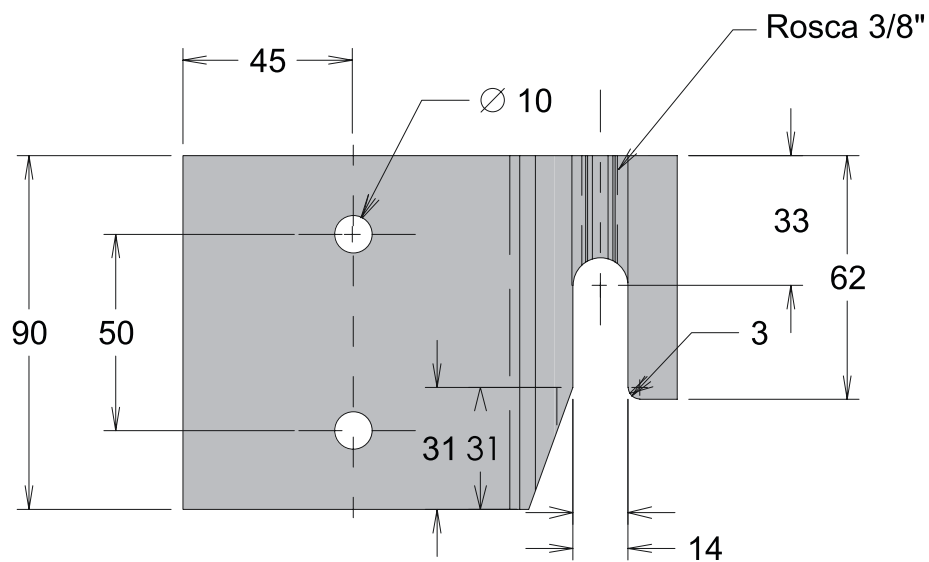

Detalhe de uso

Ancoragem Auxiliar-Canto Positivo e Negativo

Conjunto - ANC1020

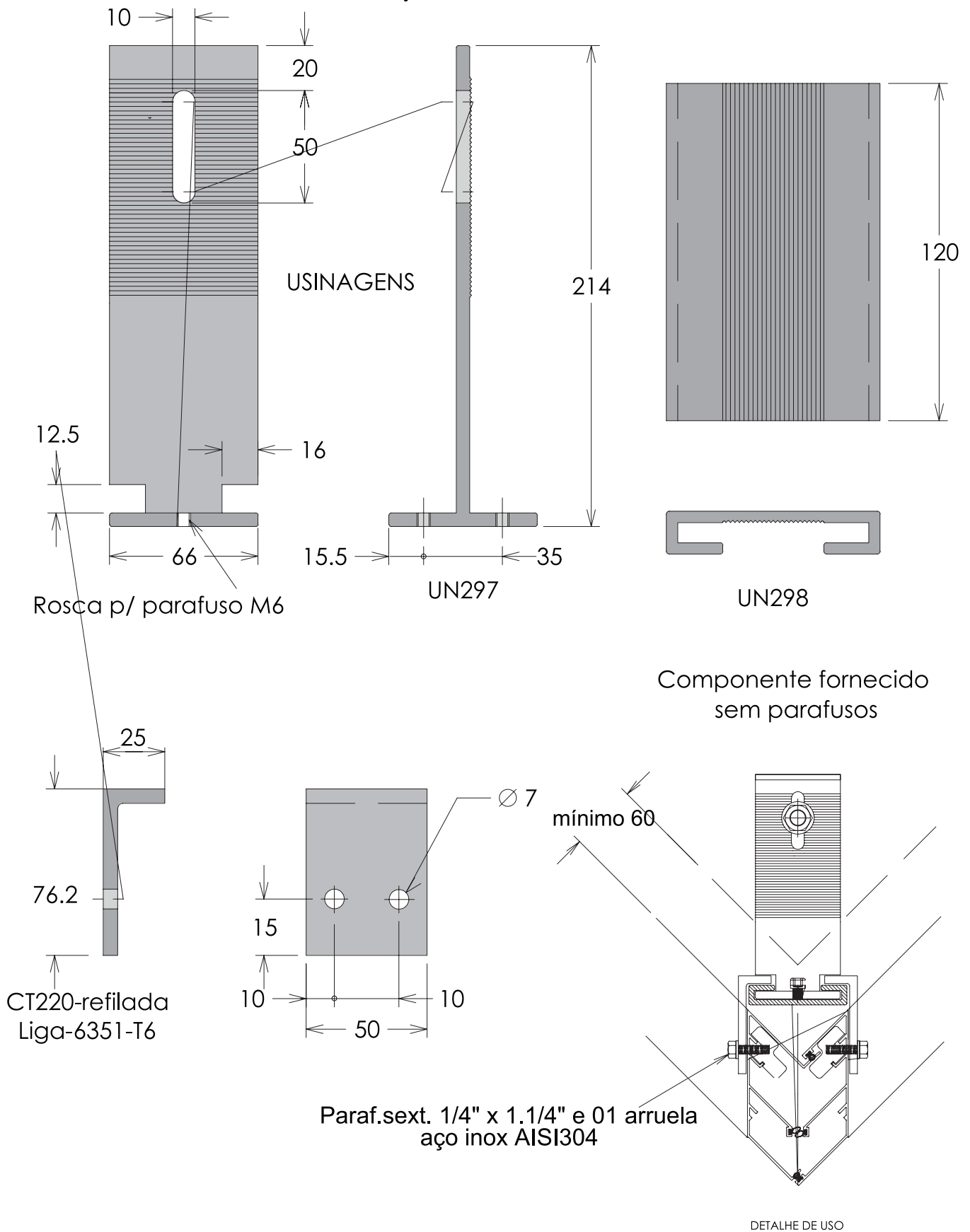

SUP745

Suporte para colunas de canto positivo e negativo

Coluna 100 mm

UN377

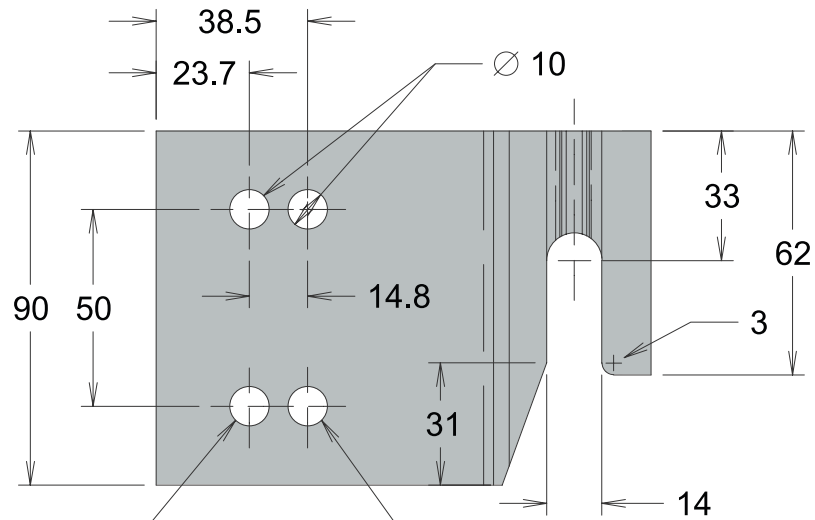

Furação para canto positivo

Furação para canto negativo

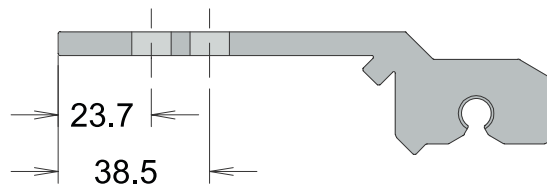

Canto Positivo

Canto Negativo

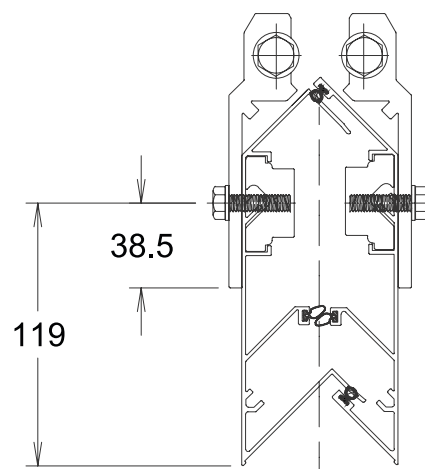
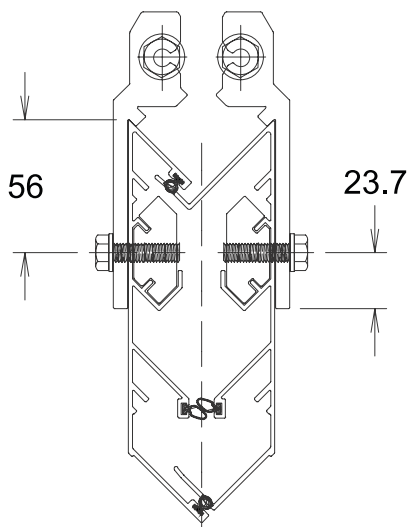

Detalhe de uso

Detalhe de uso

SUP753

Suporte para colunas de canto negativo e positivo

Coluna 127 mm

(UN377)

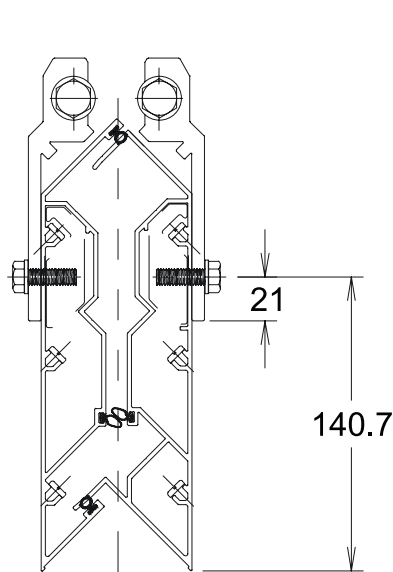
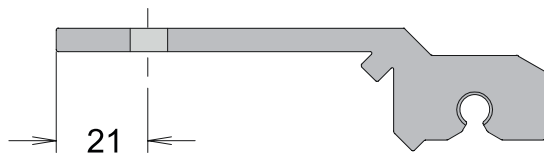
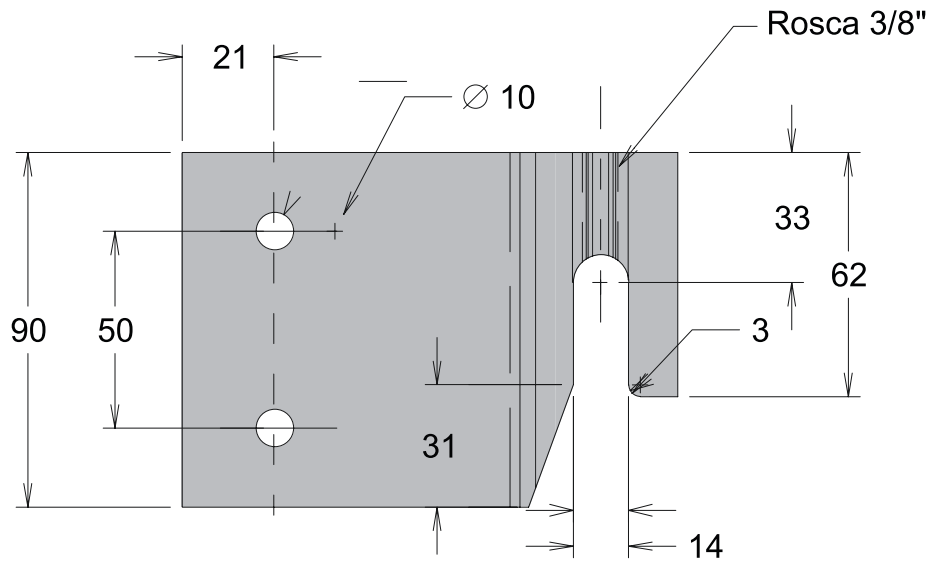

Canto negativo

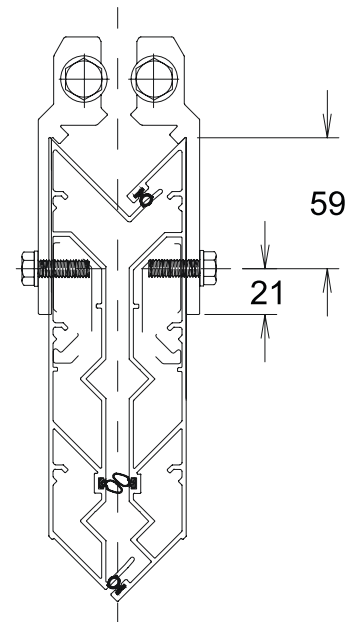

Canto positivo

Detalhe de uso

Conjunto - ANC1027

Anc. telescópica auxiliar-canto positivo - módulo 127

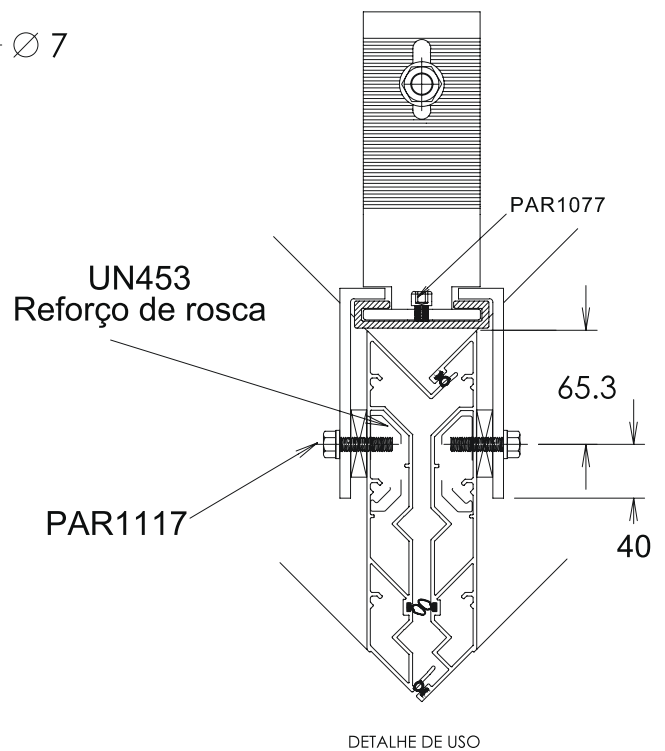
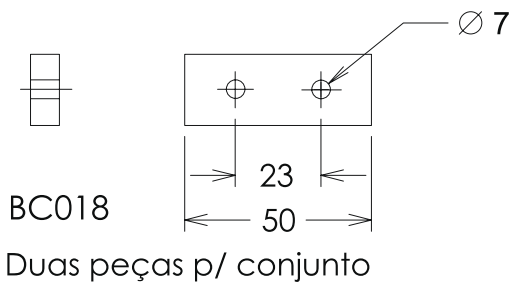
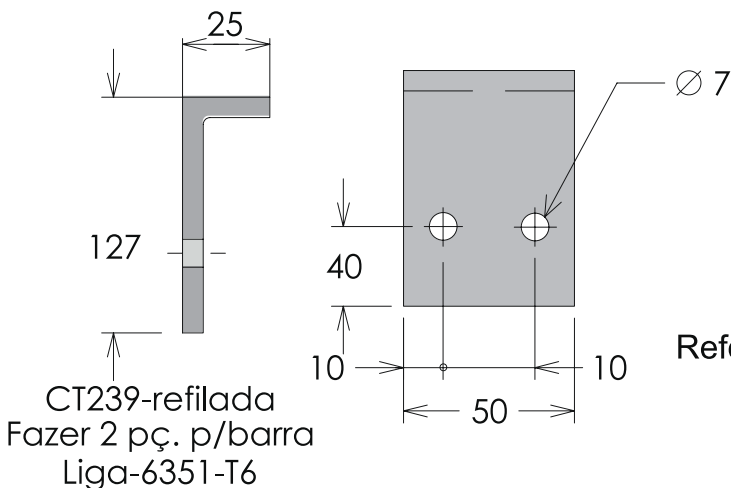
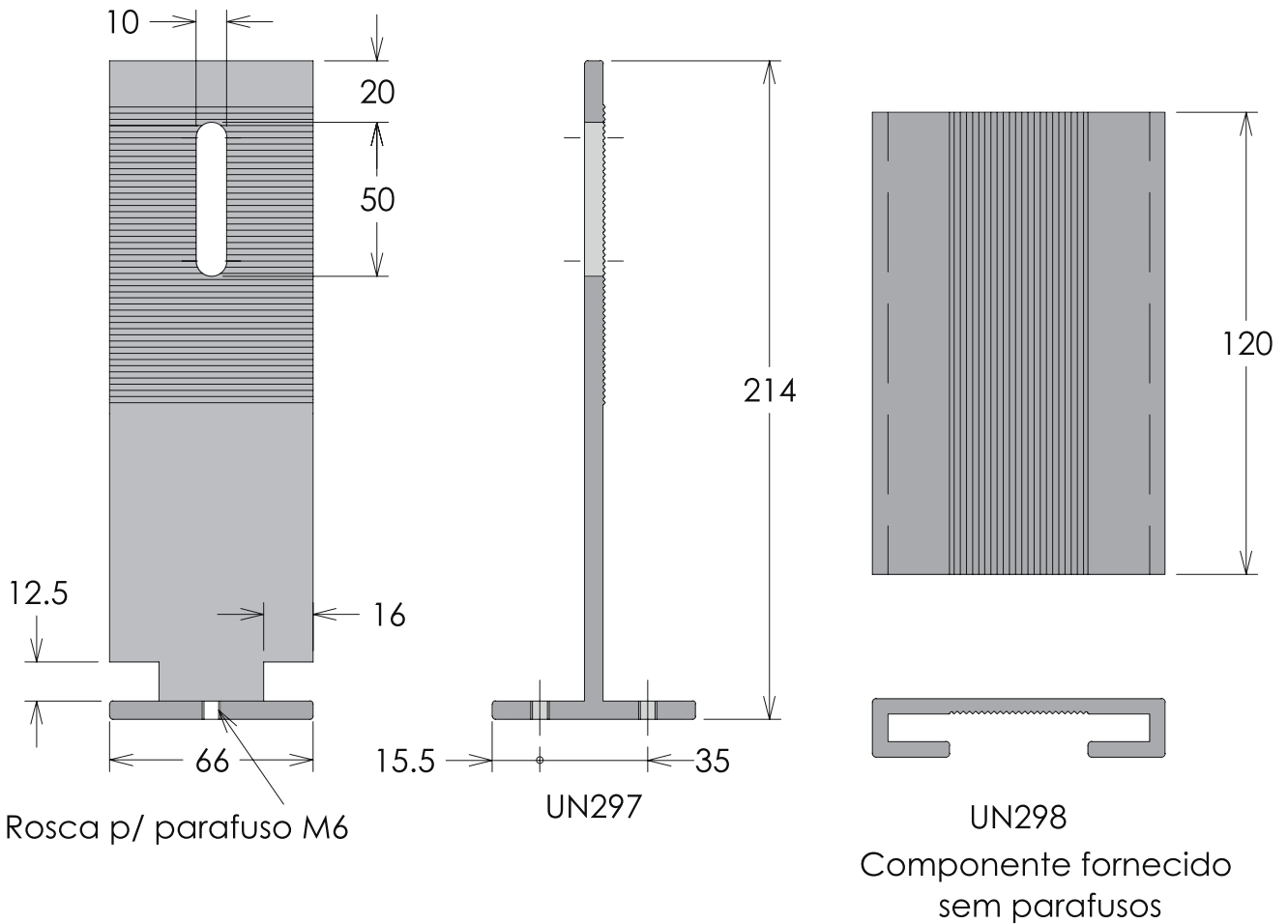

Conjunto - ANC1028

Anc. telescópica auxiliar-canto negativo - módulo 127

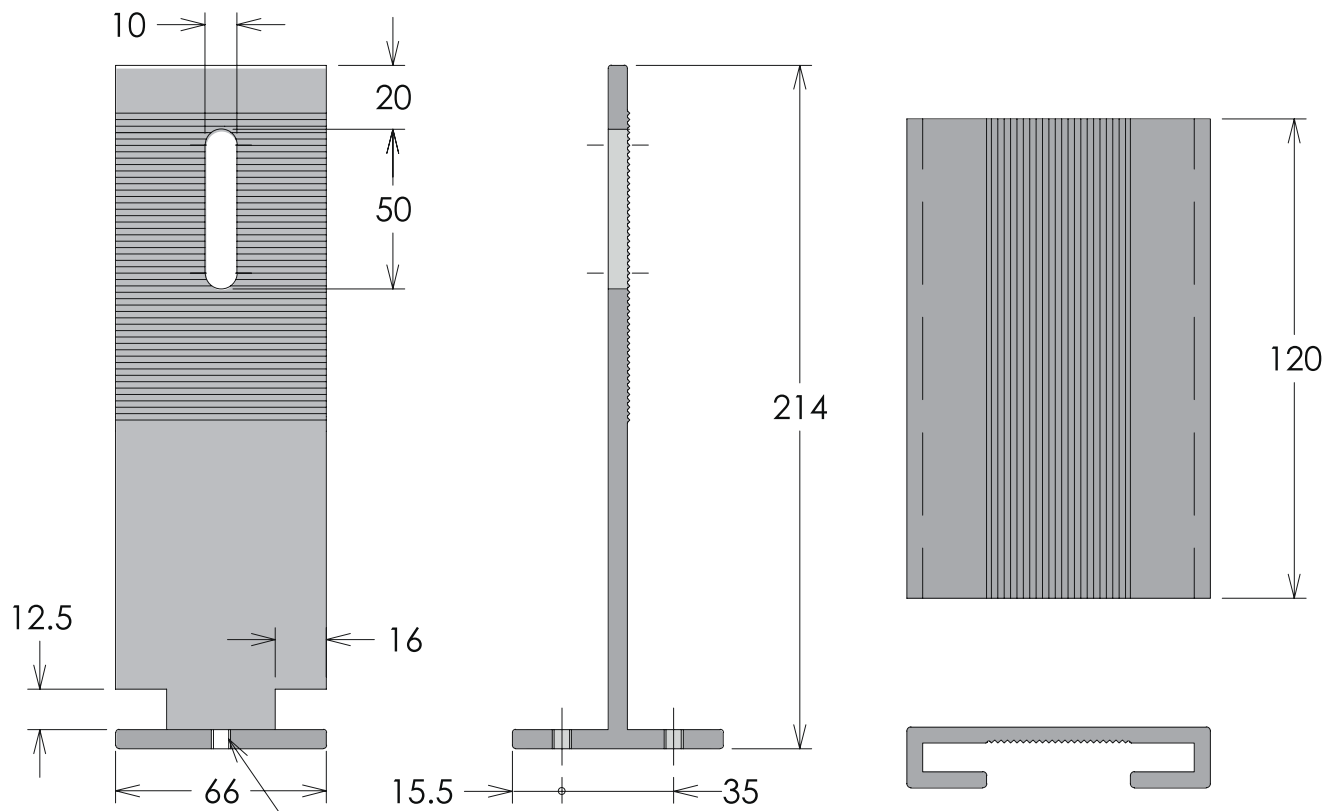

Rosca p/ parafuso M6

UN297

UN298

Componente fornecido sem parafusos

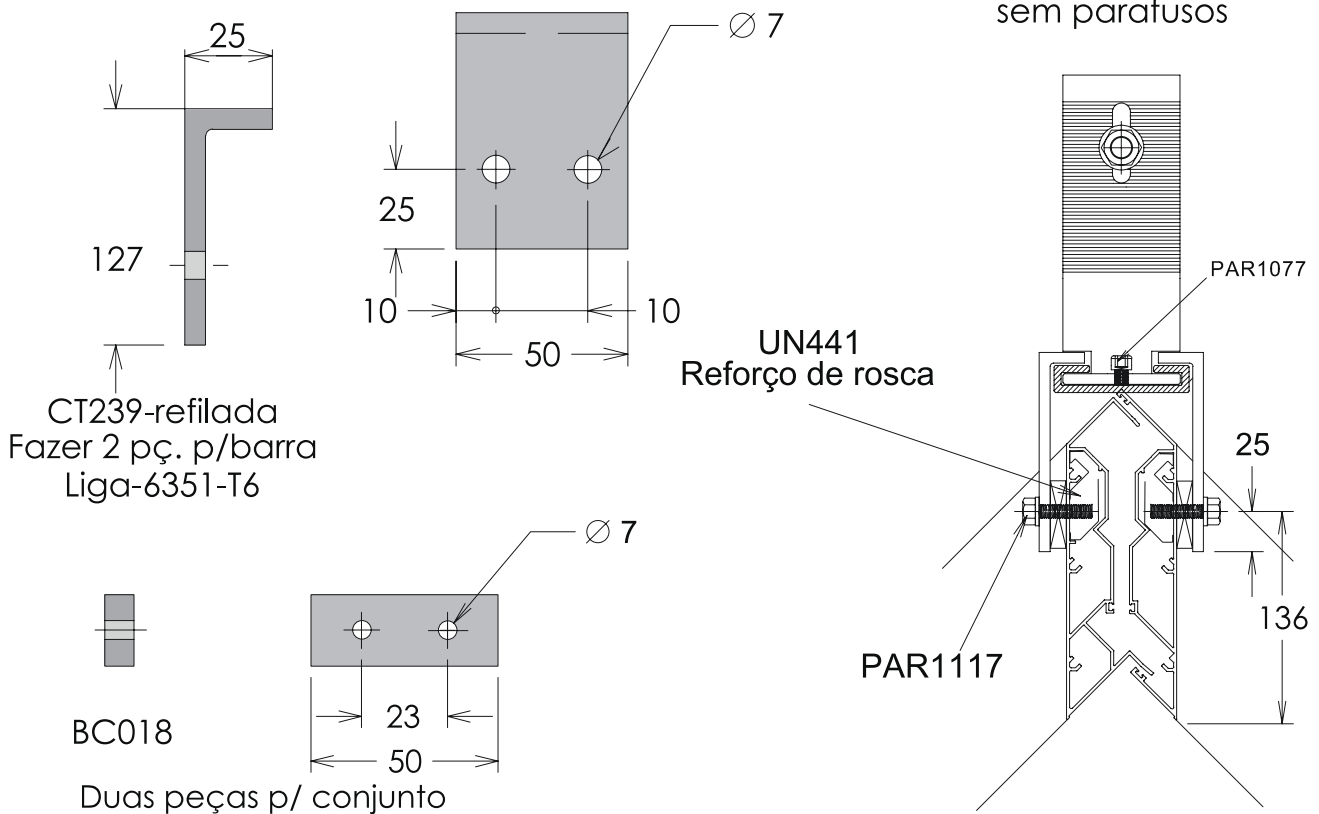

CT239-refilada
Fazer 2 pç. p/barra
Liga-6351-T6

BC018

Duas peças p/ conjunto

UN441
Reforço de rosca

PAR1117

PAR1077

ANC1014-Anc. Telescópica Auxiliar

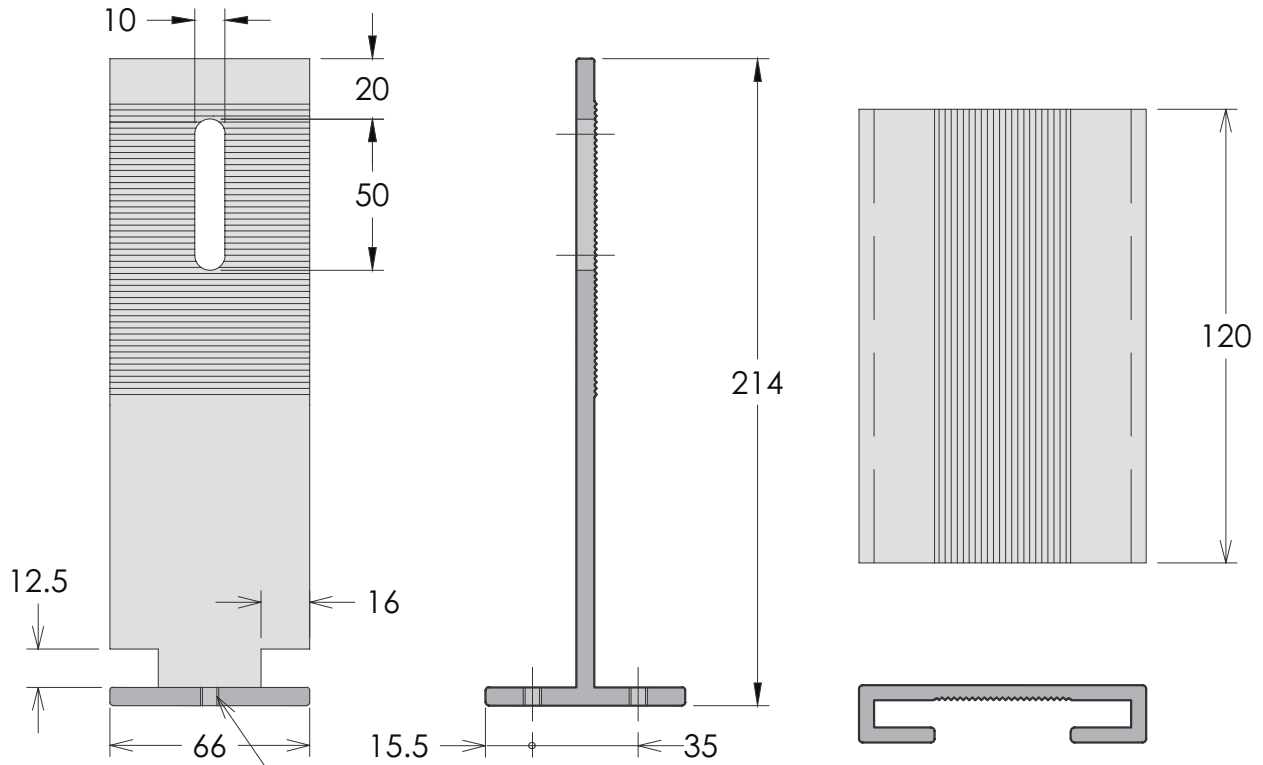

Rosca p/ parafuso M6

UN297

UN298

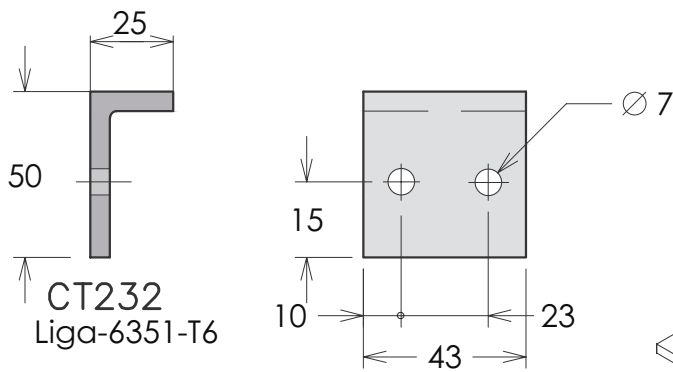

Componente fornecido sem parafusos

Duas peças p/ conjunto

Rosca p/ parafuso M6

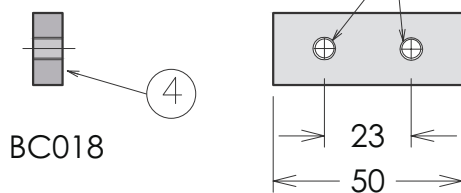

Duas peças p/ conjunto

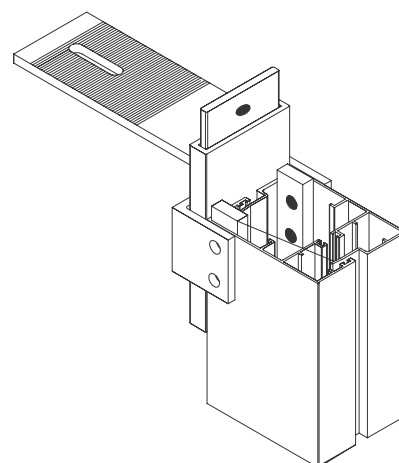

DETALHE DE USO

CANTONEIRA DE VEDAÇÃO - CT227 - Refilada

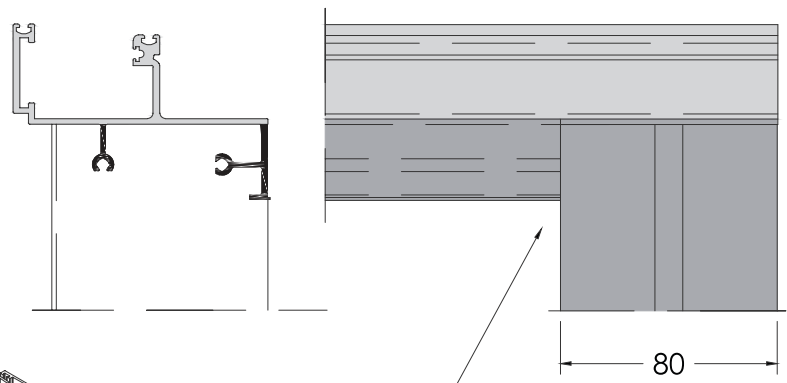
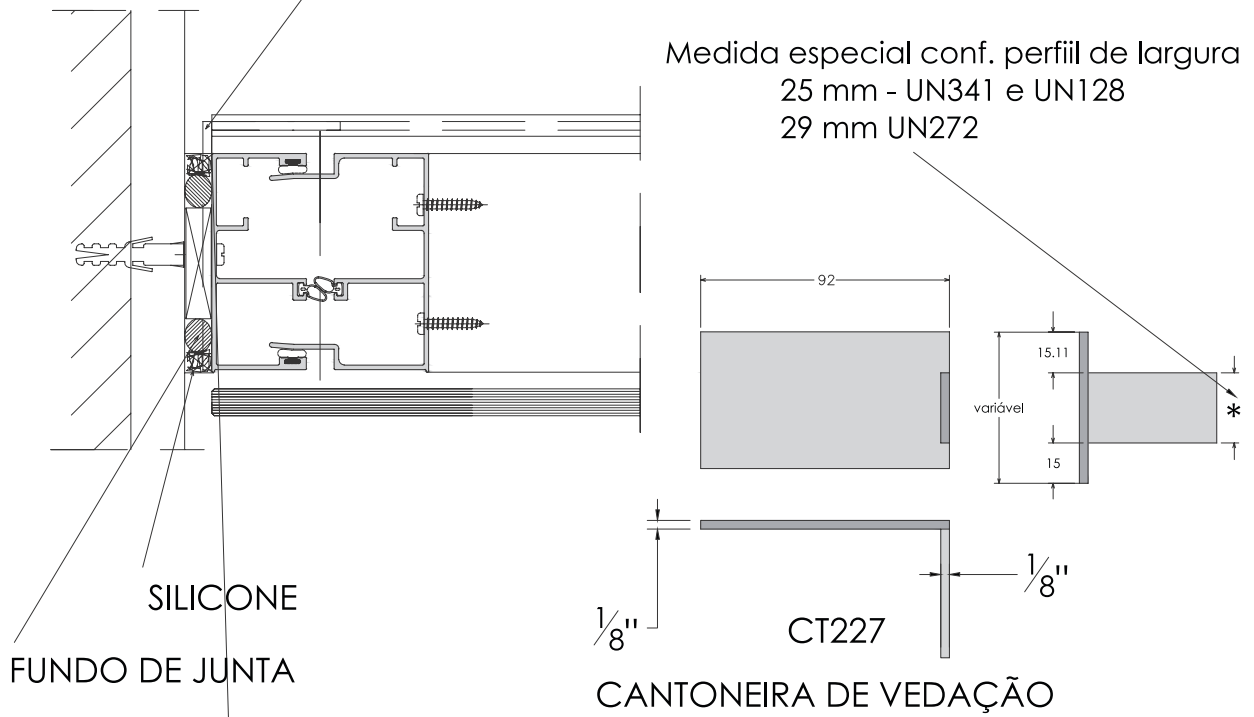

DETALHE DE USINAGEM

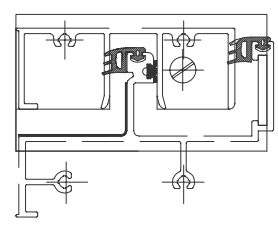
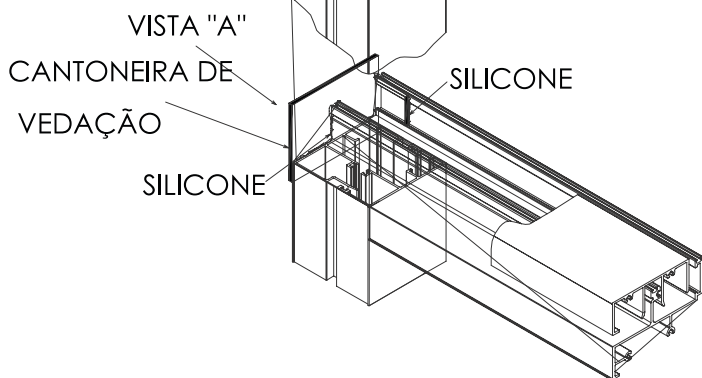

VISTA "A"

SUPOORTE

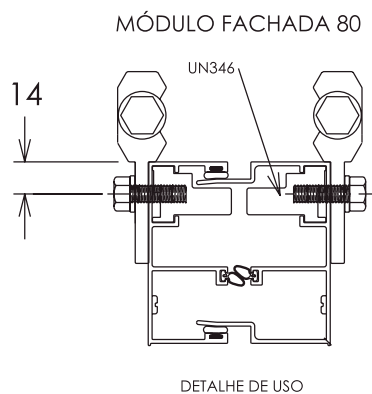
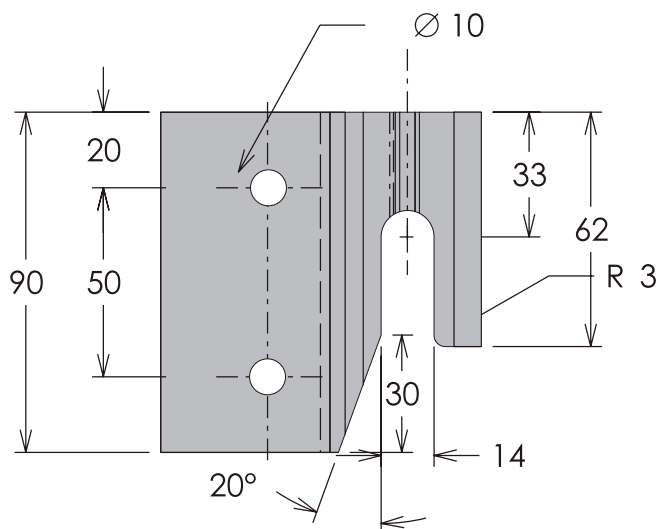

SUP720
UN099

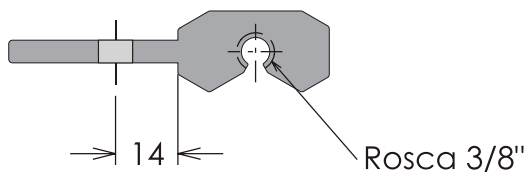

SUPOORTE

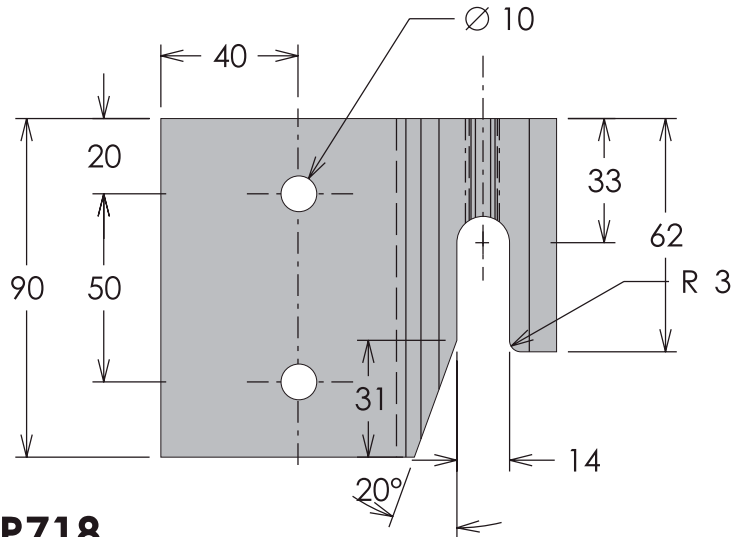

MÓDULO FACHADA 100

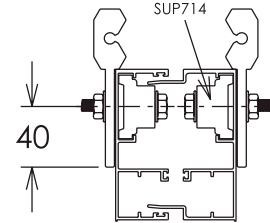

DETALHE DE USO

SUP718

UN105

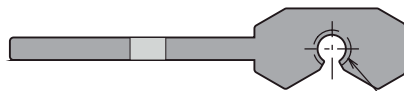

Rosca 3/8"

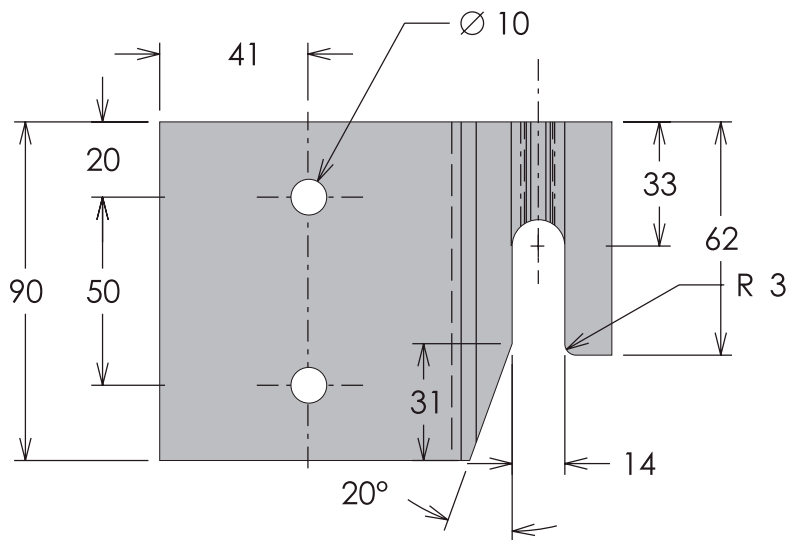

MÓDULO FACHADA 127

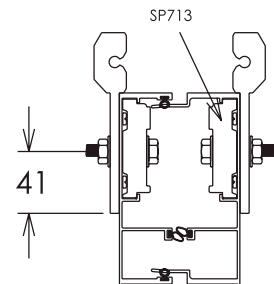

DETALHE DE USO

SUP719

UN208



Rosca 3/8"

SUPOORTE

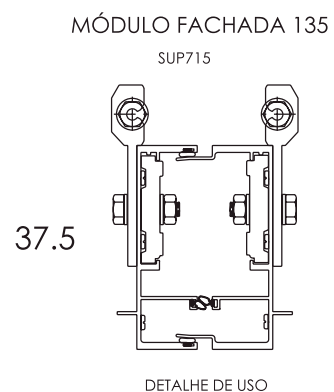
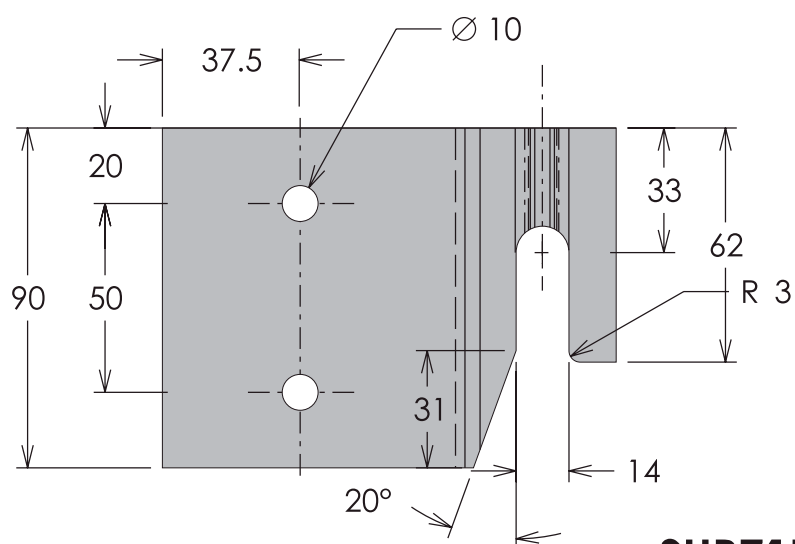

SUP717

UN208

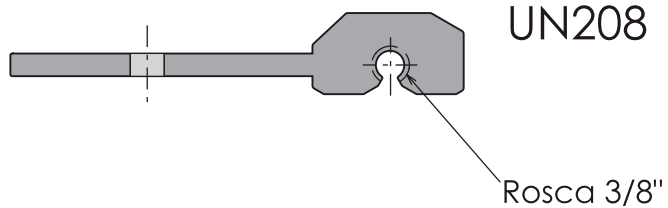

Tirante positivo - Coluna de canto 80

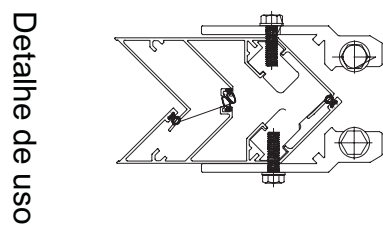
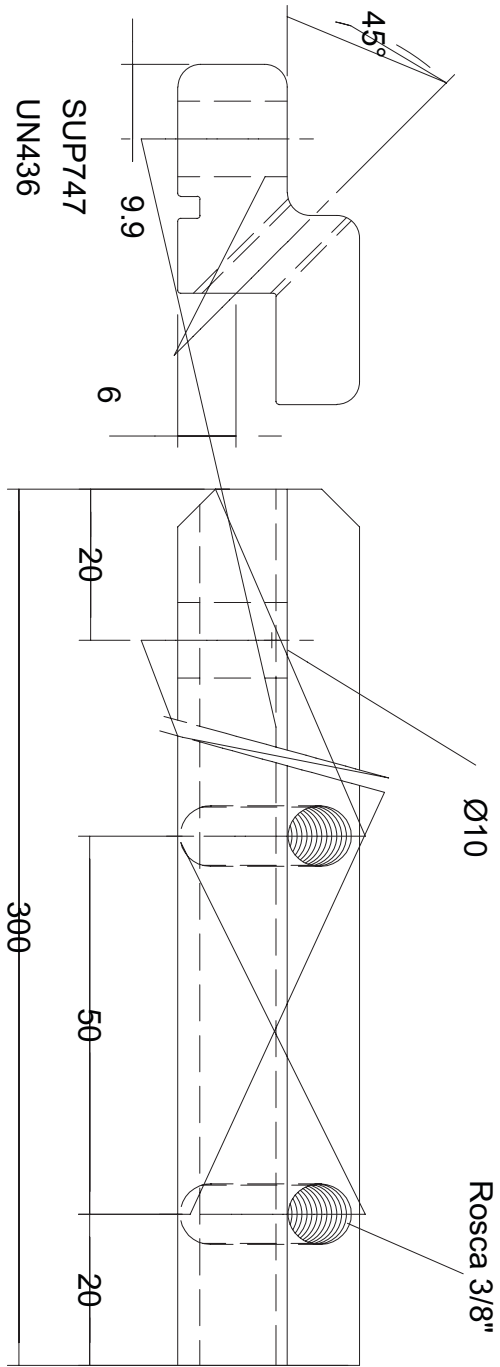

Detalhe de uso

Tirante negativo - Coluna de canto 80

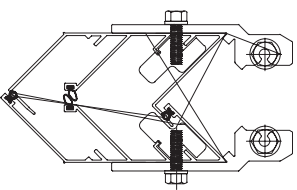
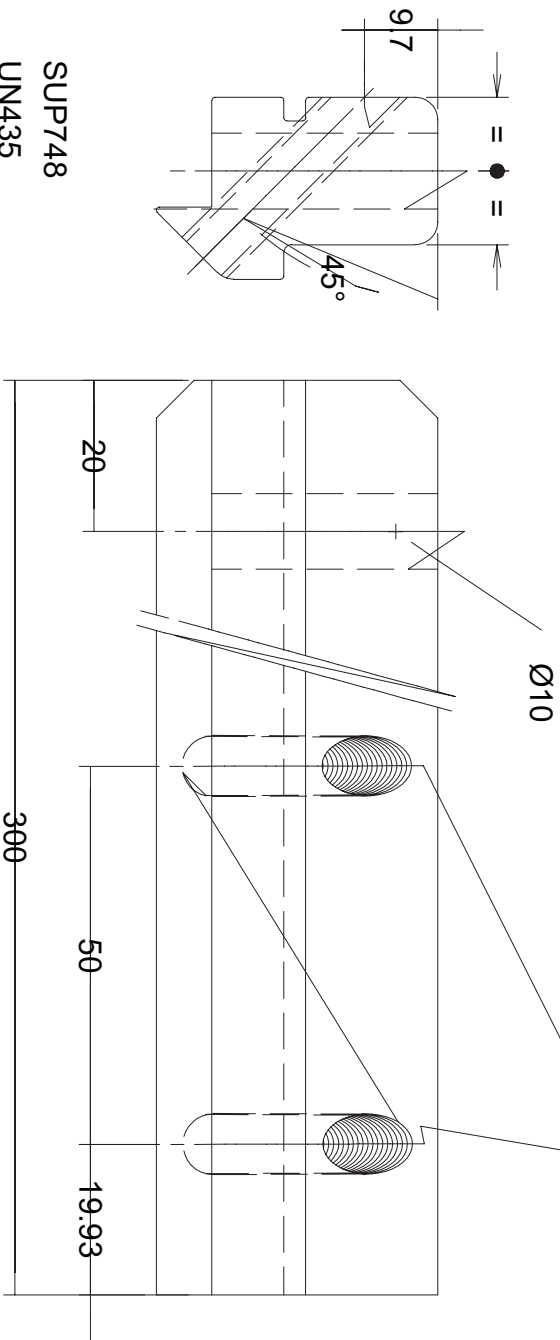

Detalhe de uso

Obs: O comprimento de 300 mm poderá ter variação conforme configuração da obra

Tirante negativo - Coluna de canto 100

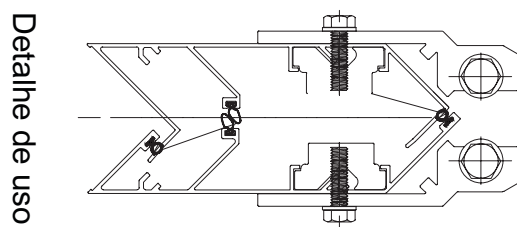
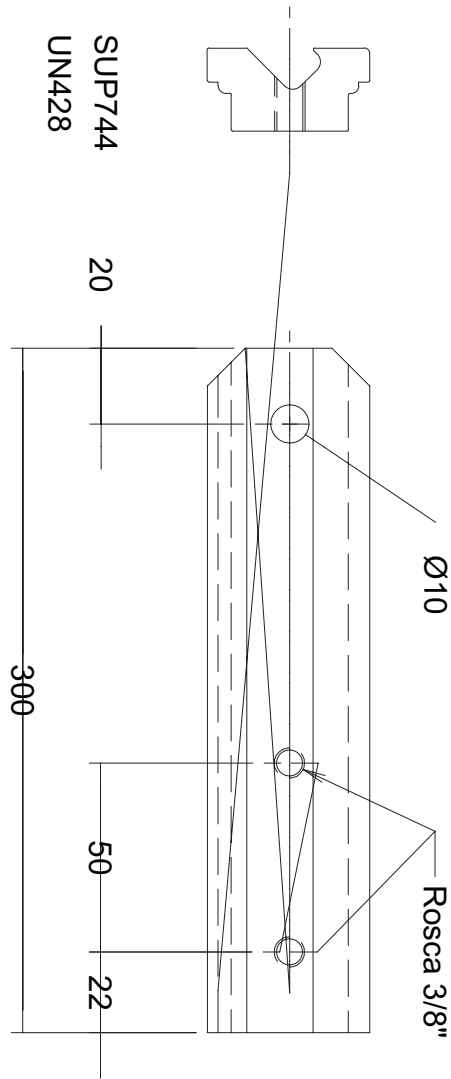

Detalhe de uso

Obs: O comprimento de 300 mm poderá ter variação conforme configuração da obra

Tirante positivo e negativo - Coluna de canto 127

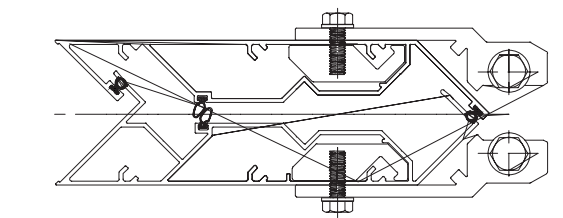
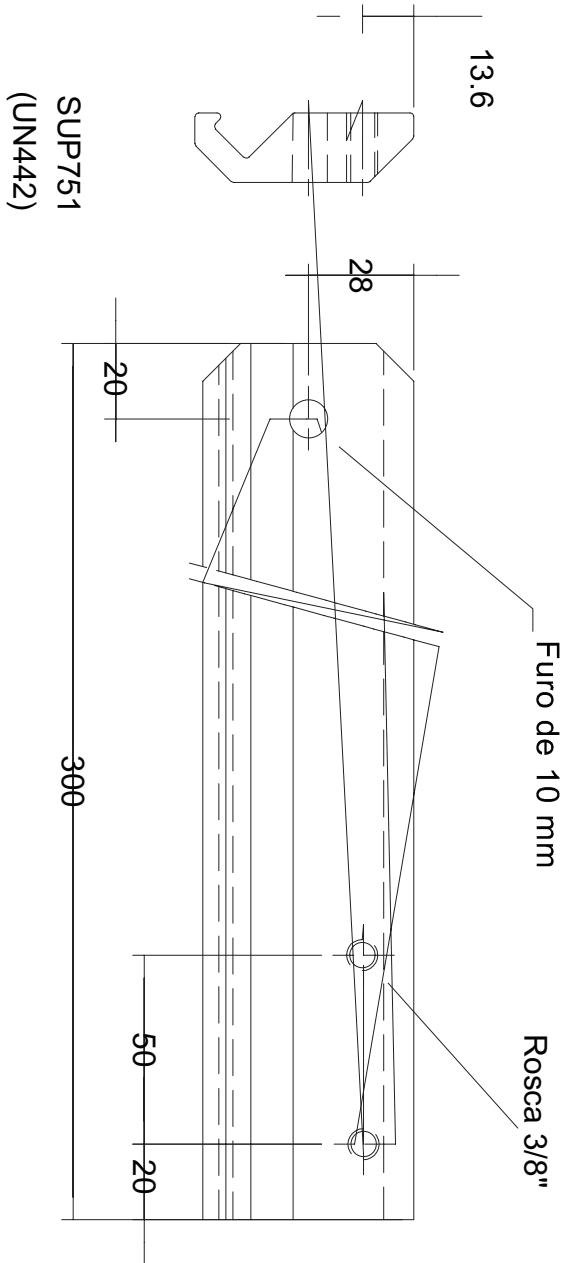

Canto negativo

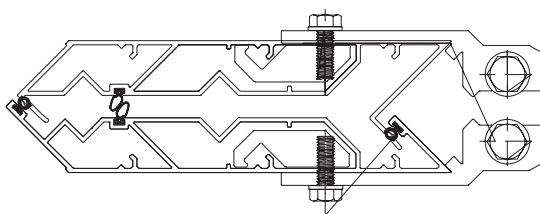

Canto positivo

Detalhe de uso

Obs: O comprimento de 300 mm poderá ter variação conforme configuração da obra

Tirantes

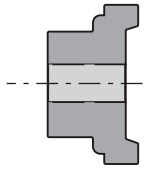

SUP714
UN268

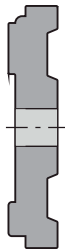
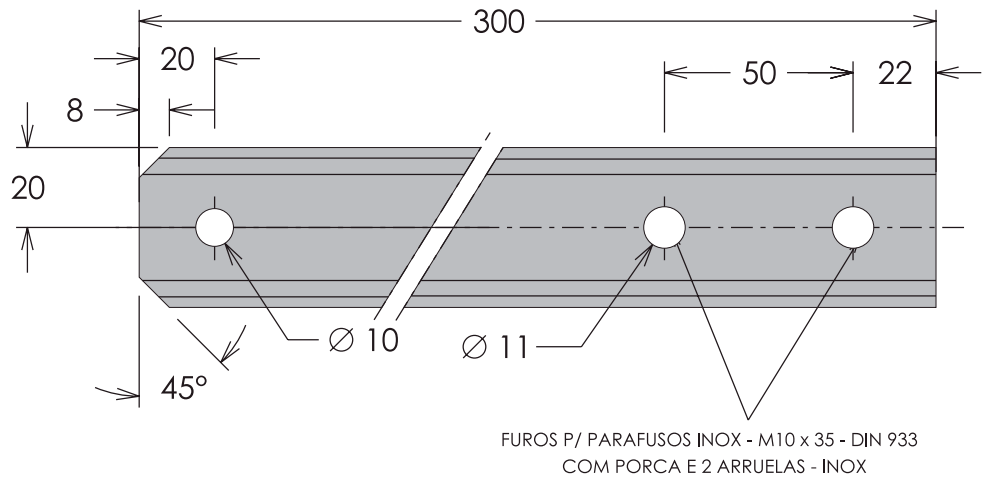

SUP715
UN215

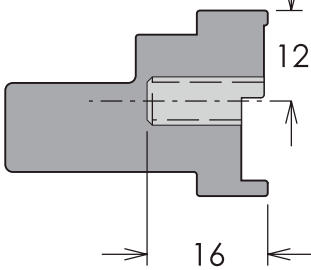
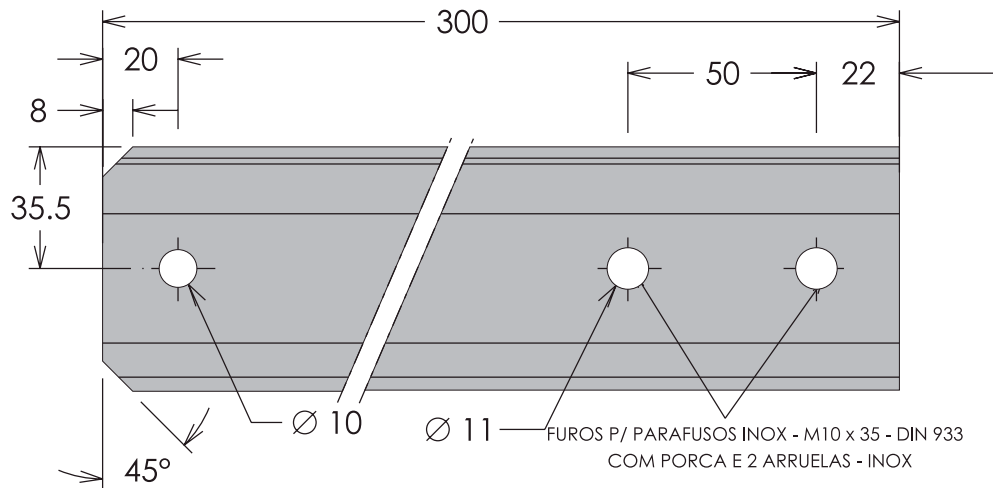

SUP721
UN346

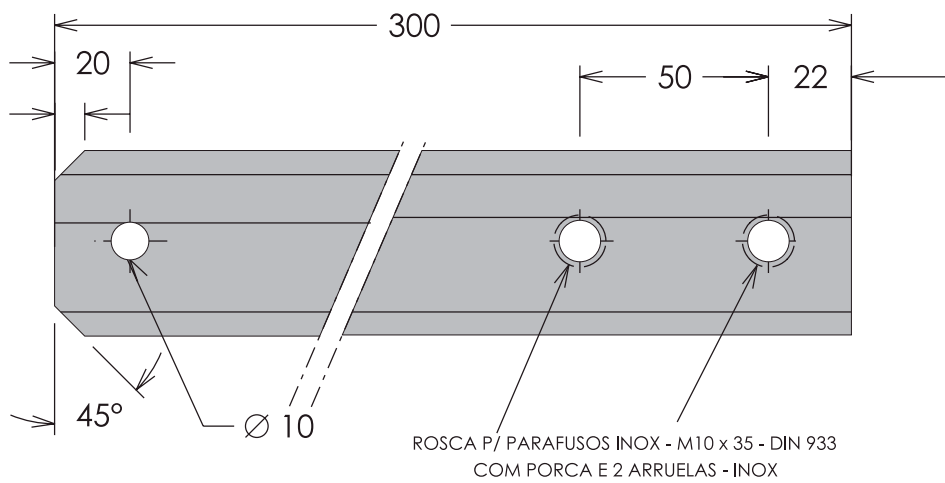

Obs: O comprimento de 300 mm poderá ter variação conforme configuração da obra

Tirantes

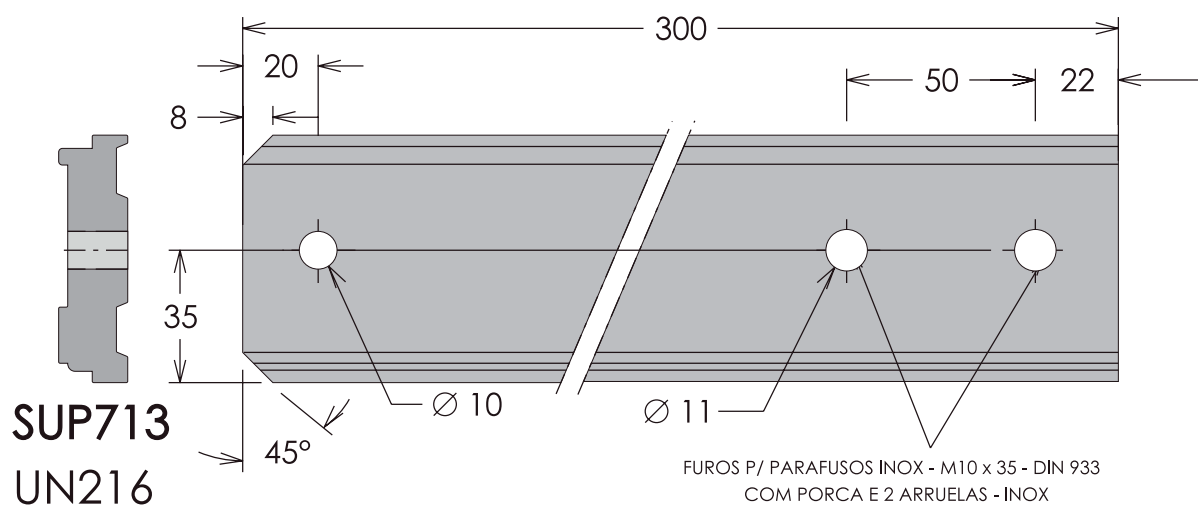

Obs: O comprimento de 300 mm poderá ter variação conforme configuração da obra

Tampa Módulo 60

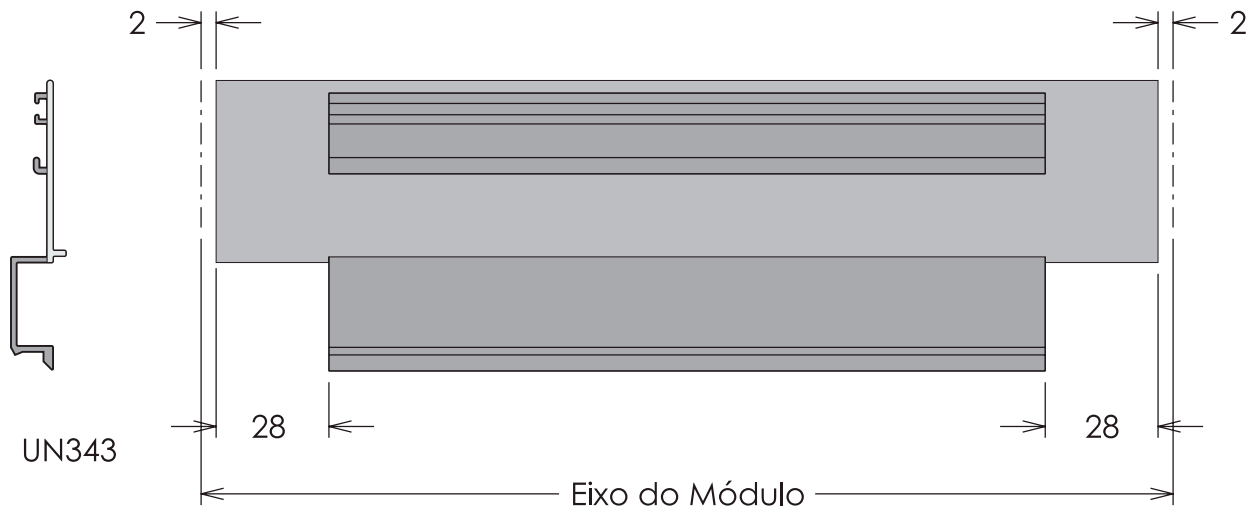

Tampa Módulo 80/25

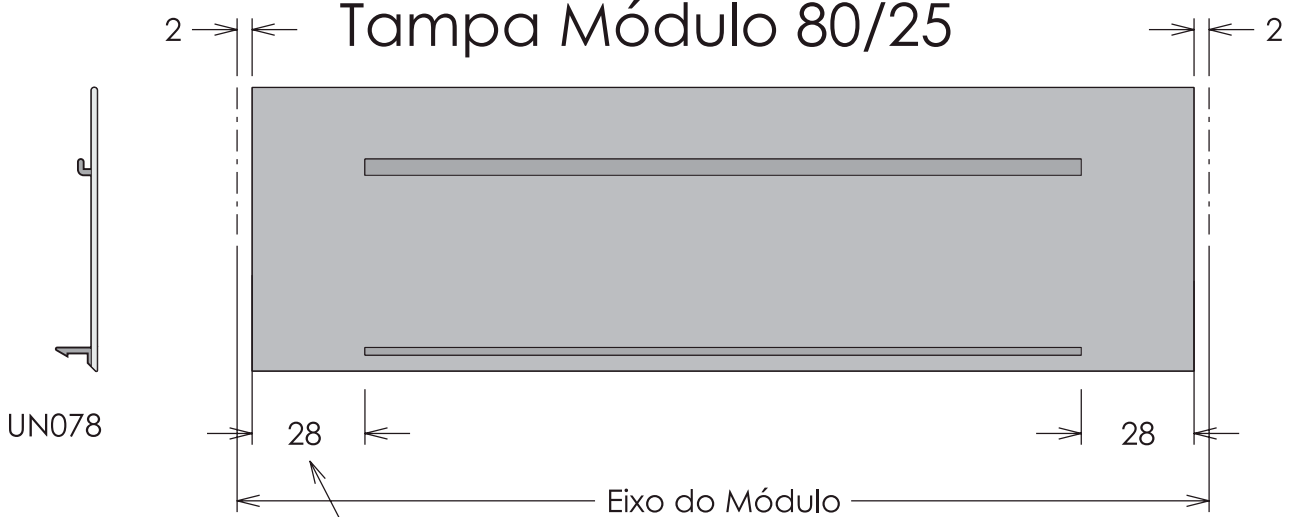

Usar Mesmas Usimagens p/ UN015/UN-27/UN032

Tampa Módulo 80/38

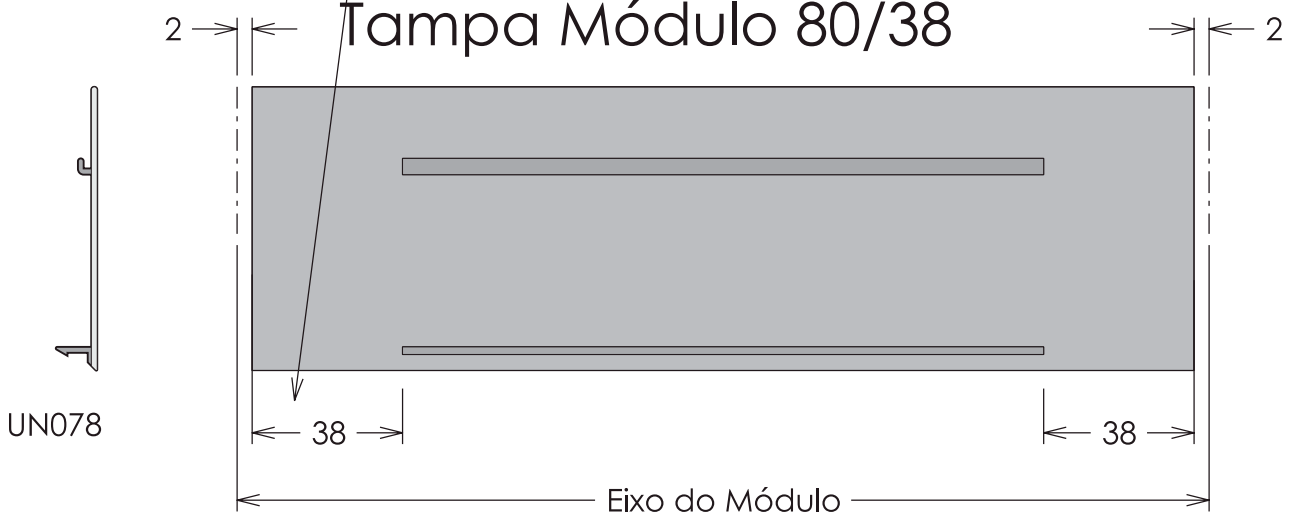

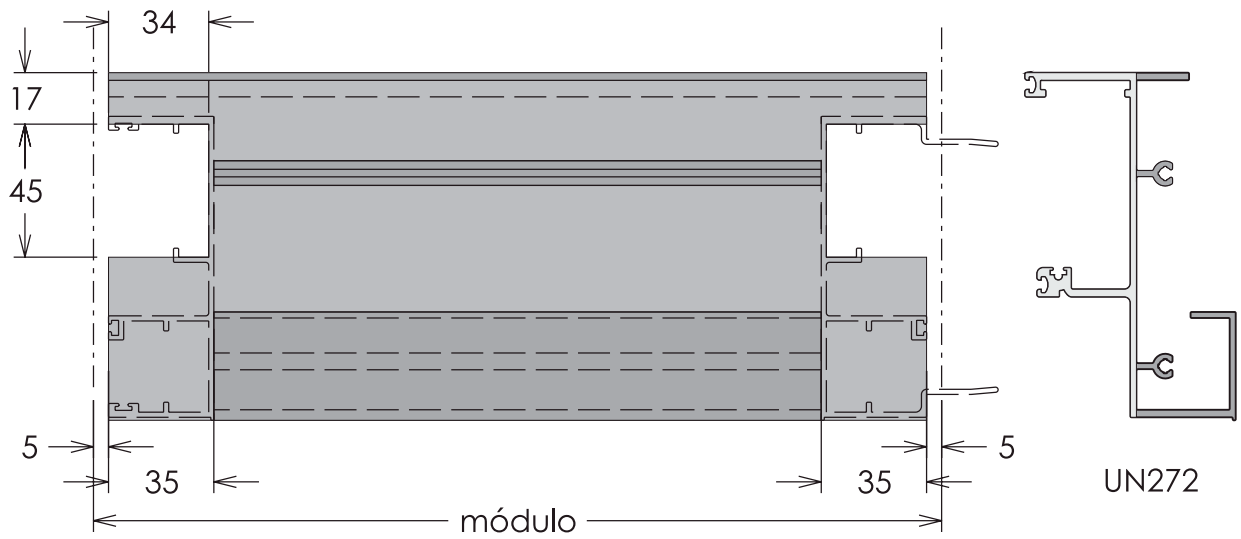
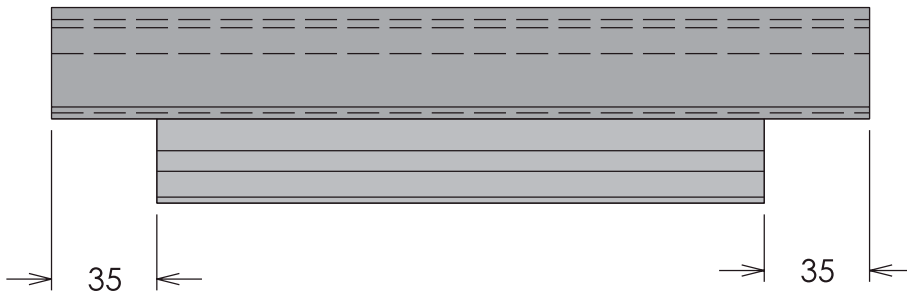
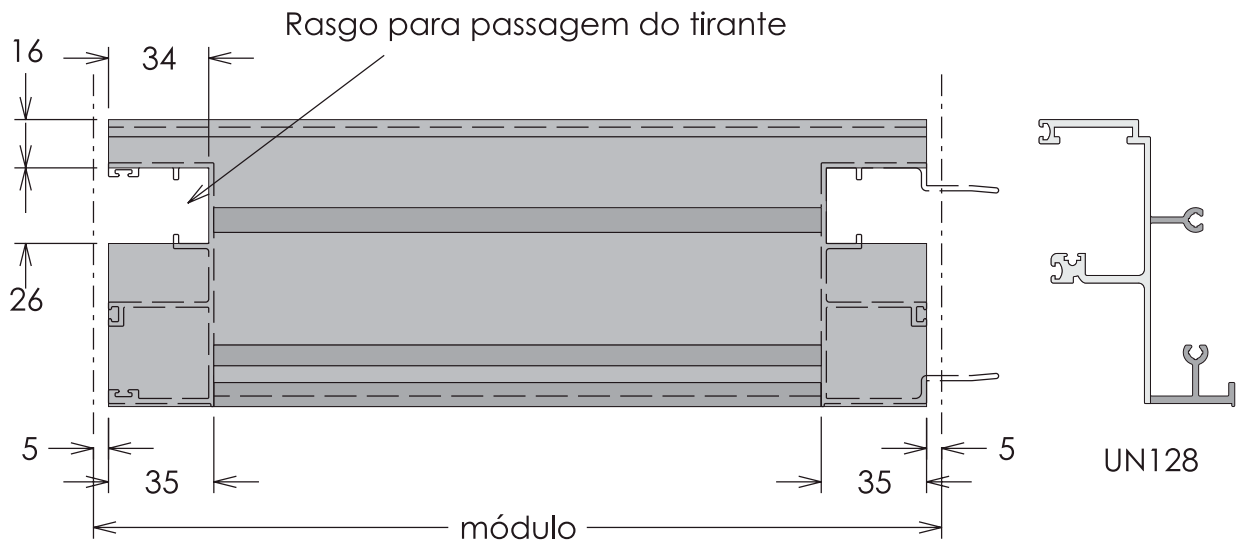

FAZER AMOSTRA PARA TESTE

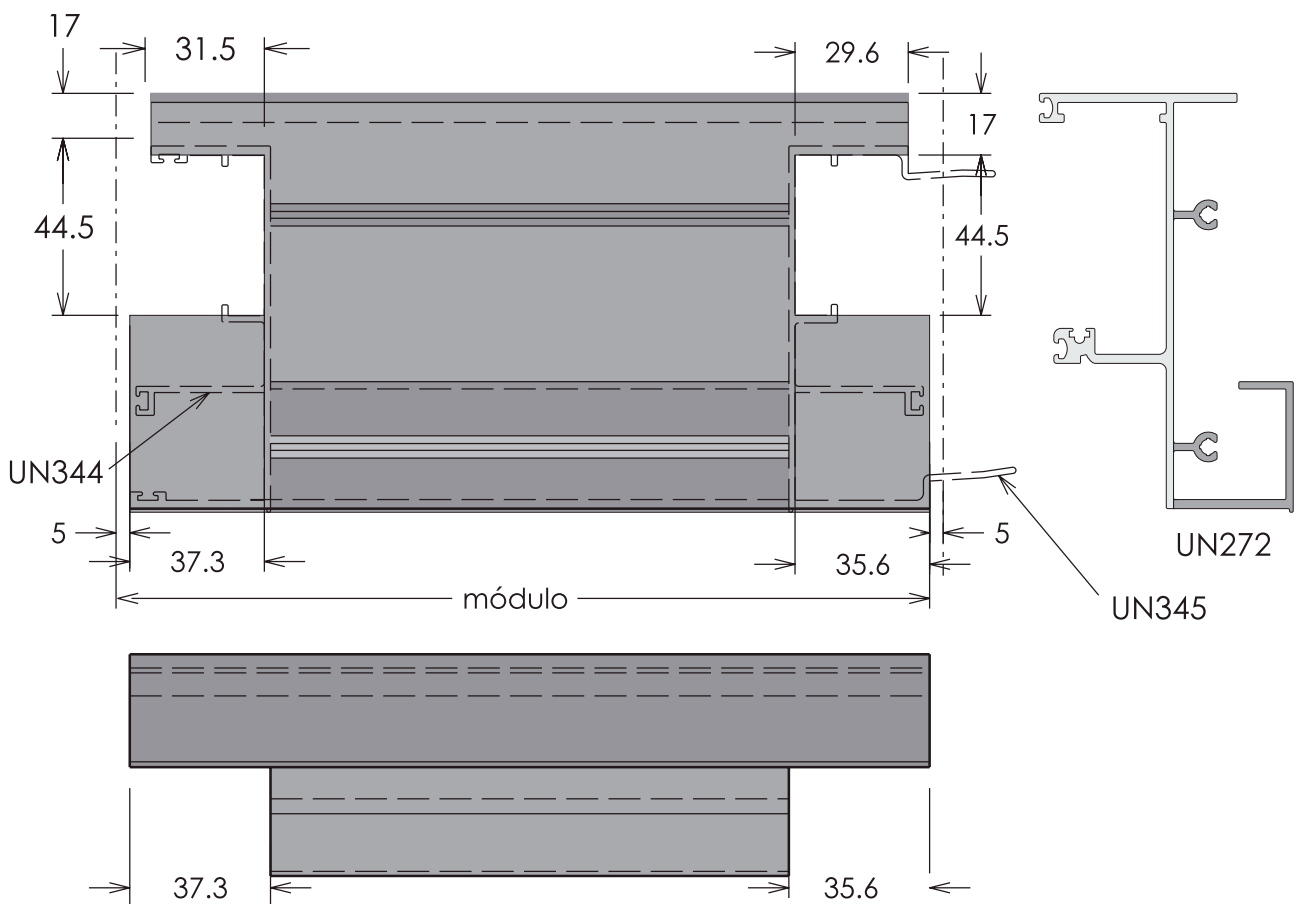
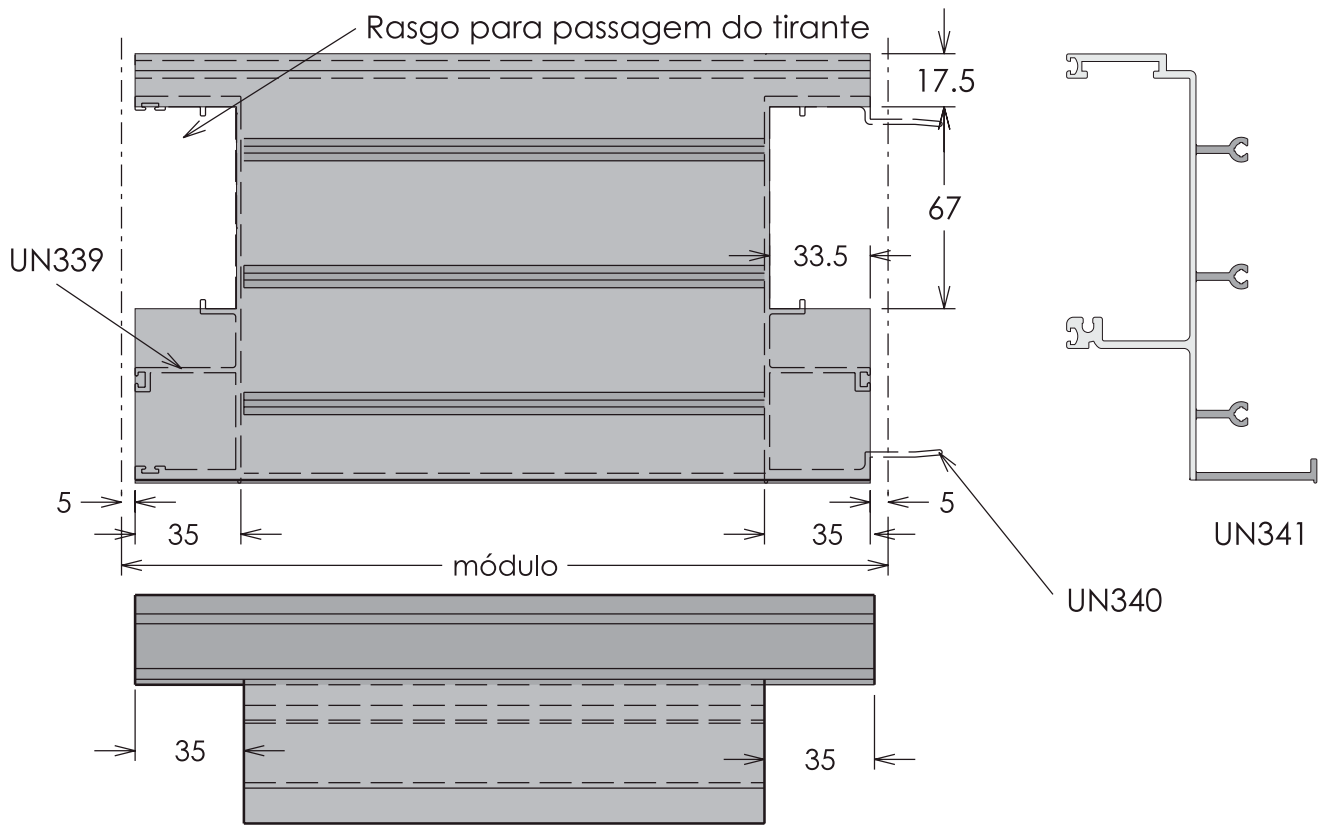

FAZER AMOSTRA PARA TESTE

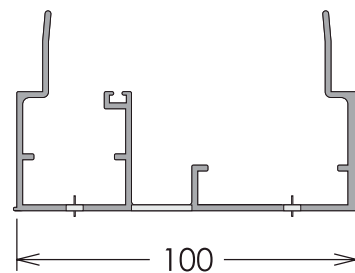
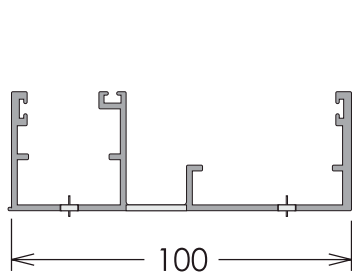
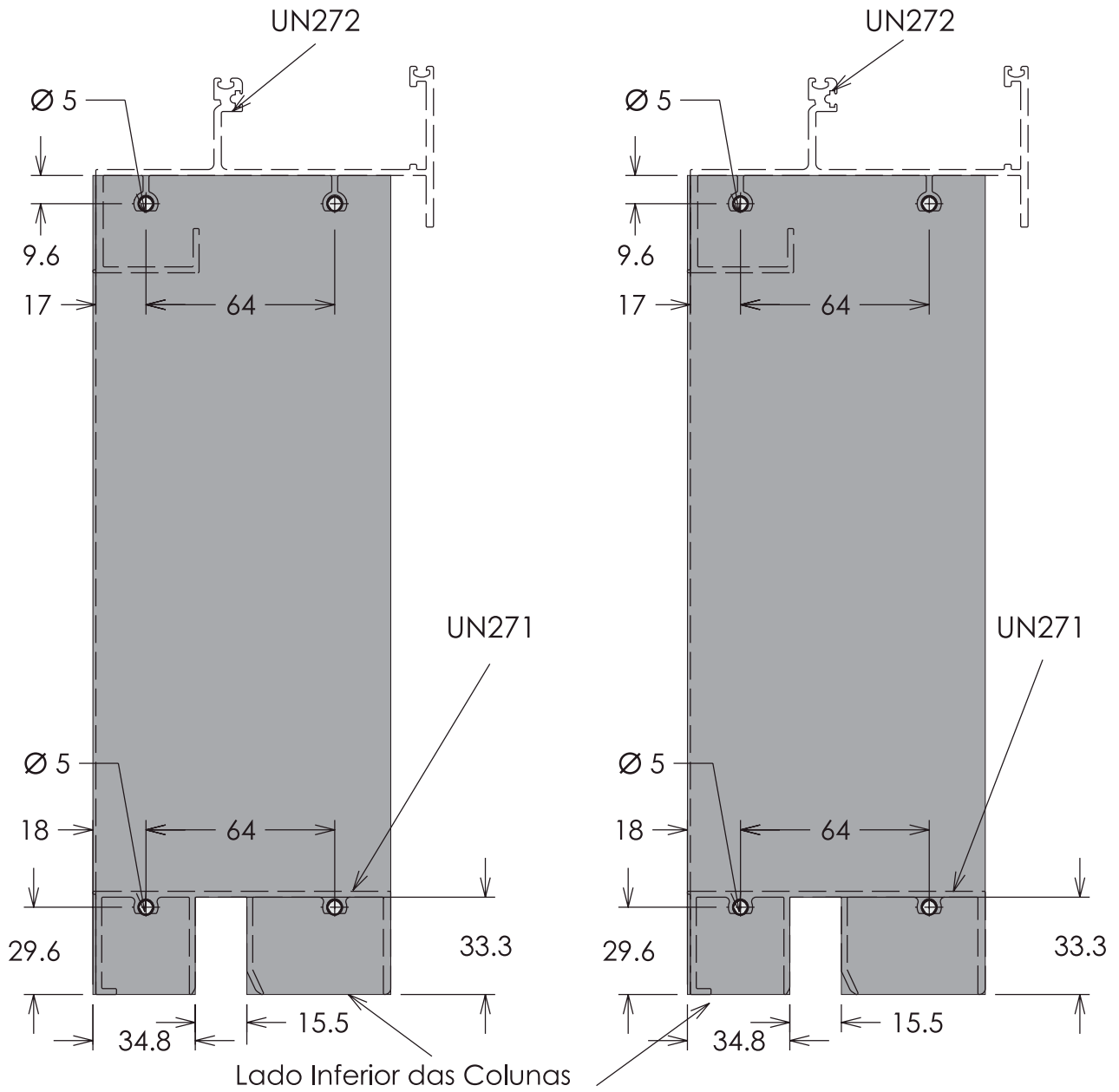

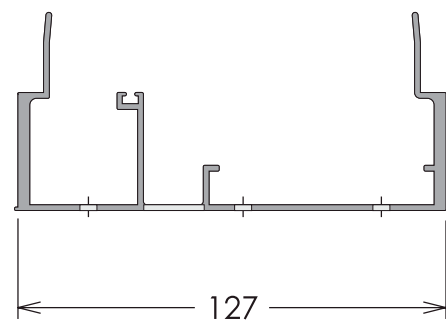
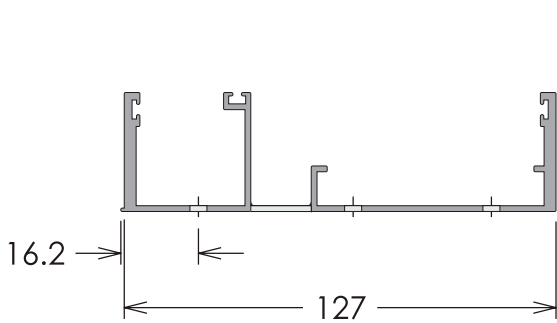
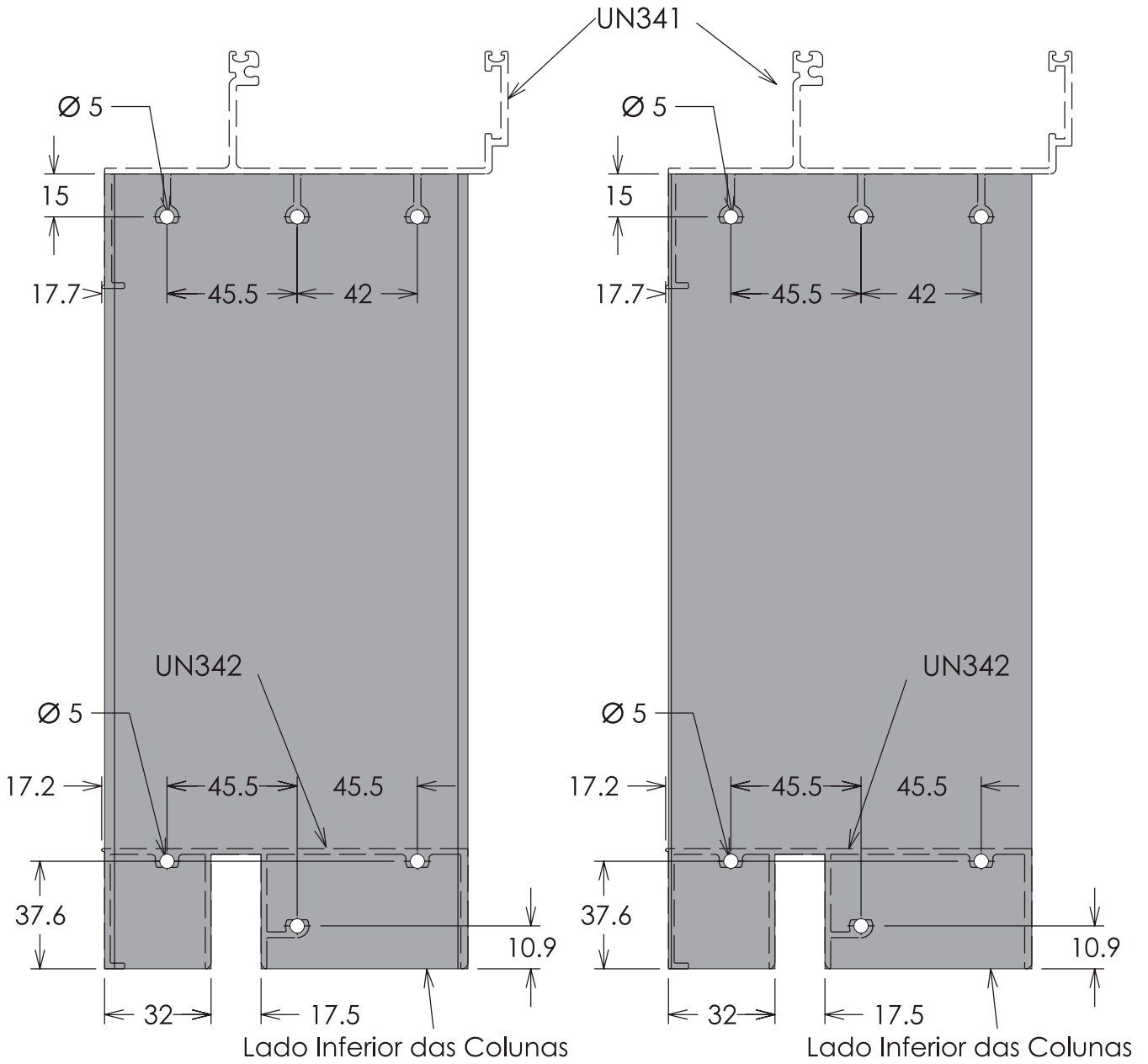

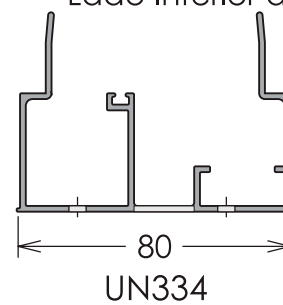
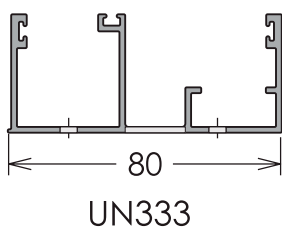
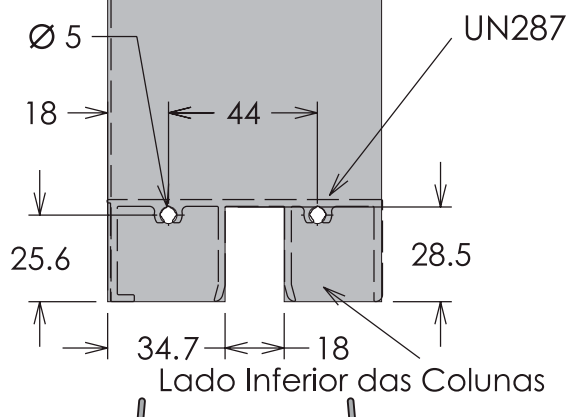
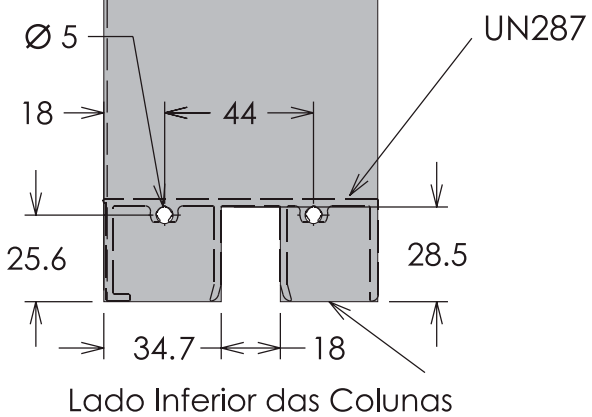
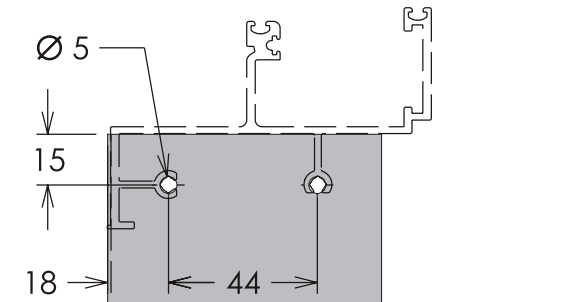
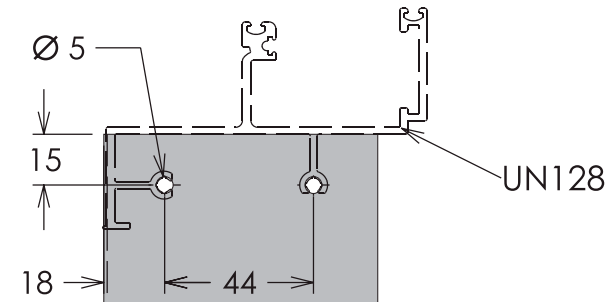
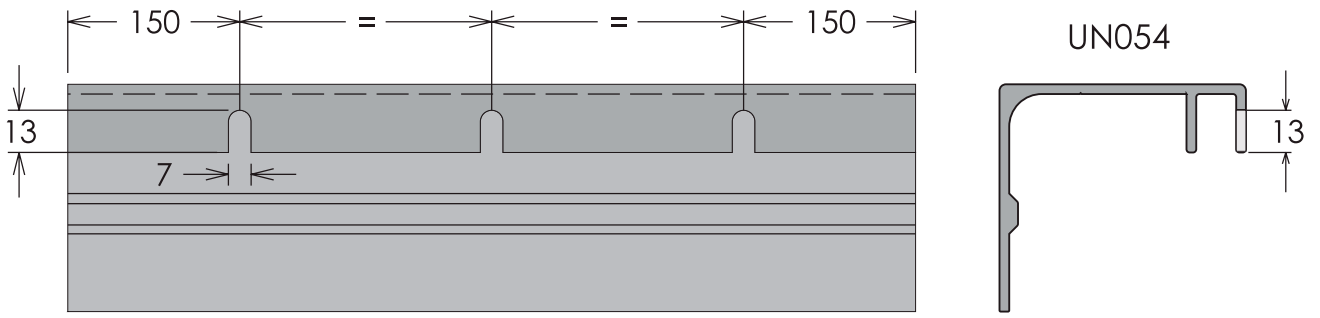

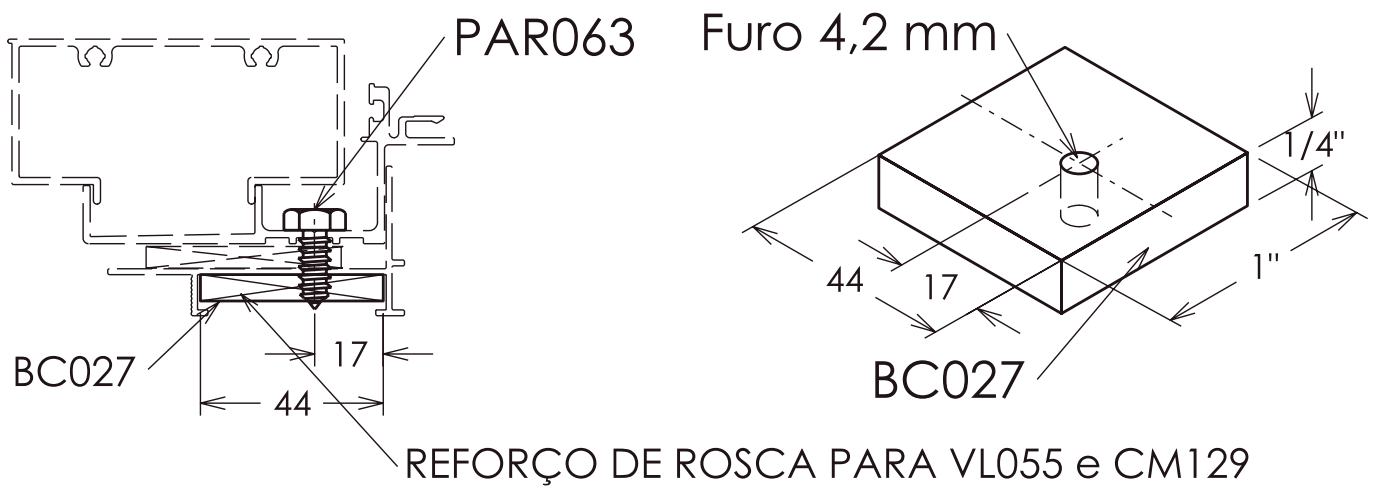
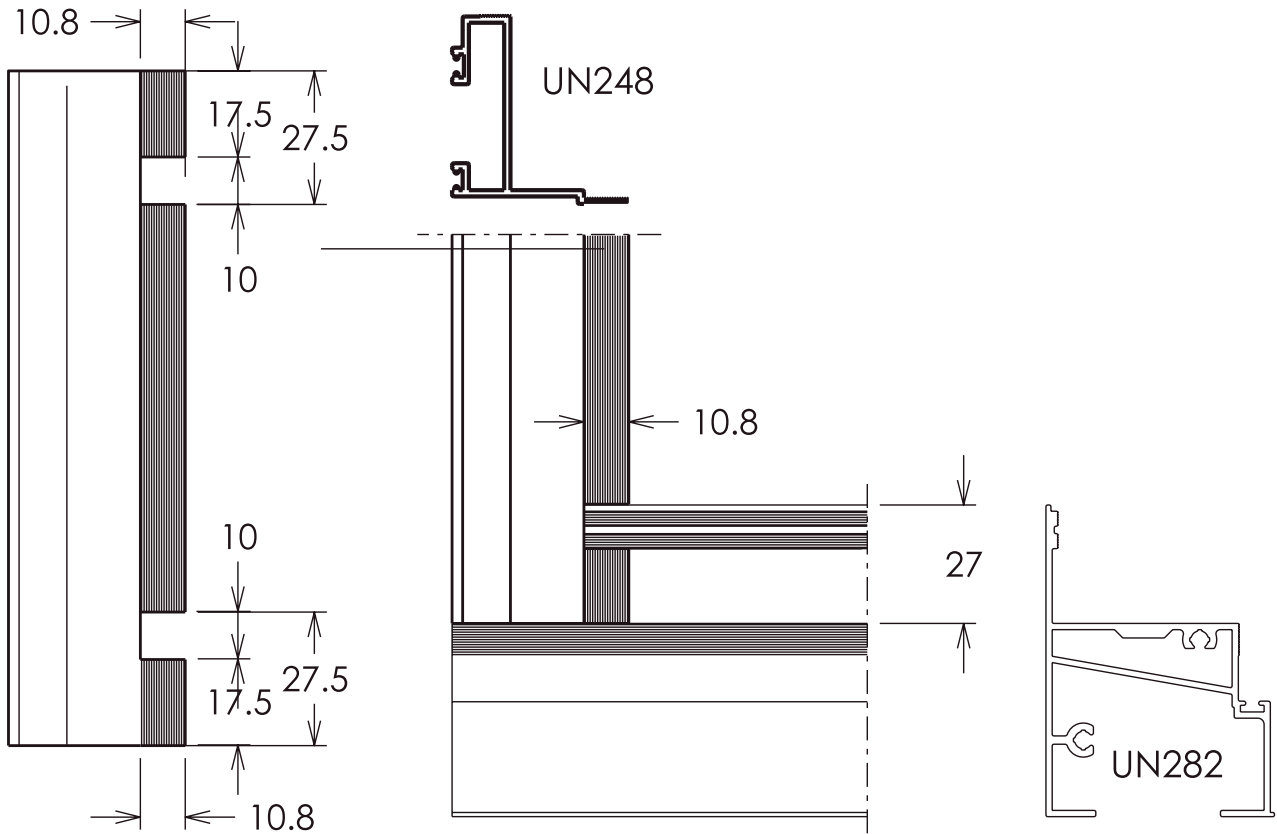

Usinagem para colocação do NYL490

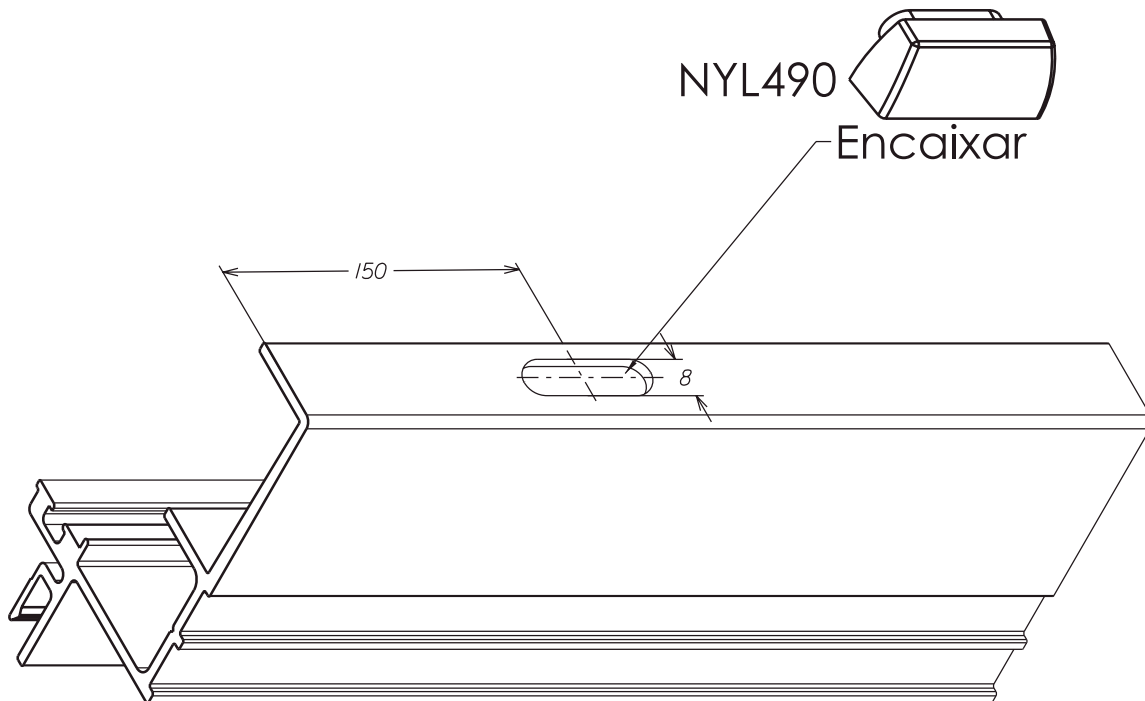

Usinagem para colocação do CT005

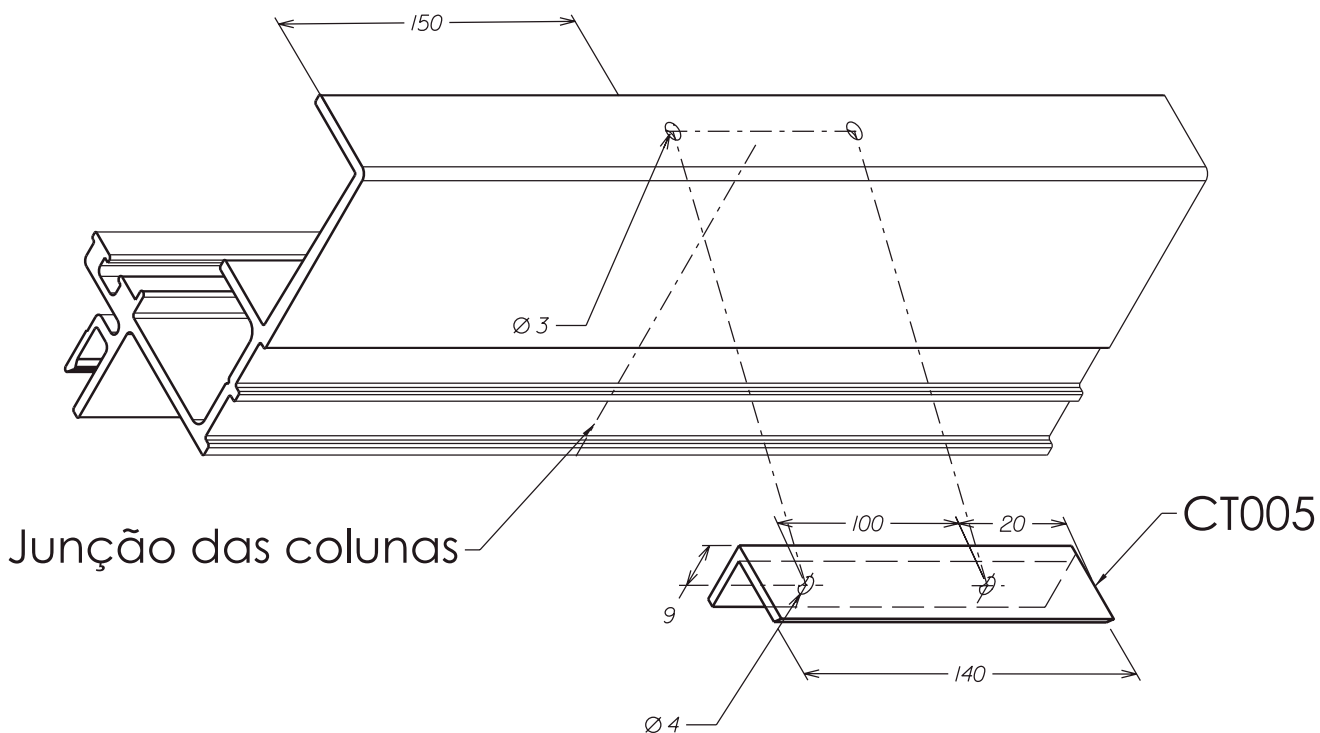

Módulo 60-25

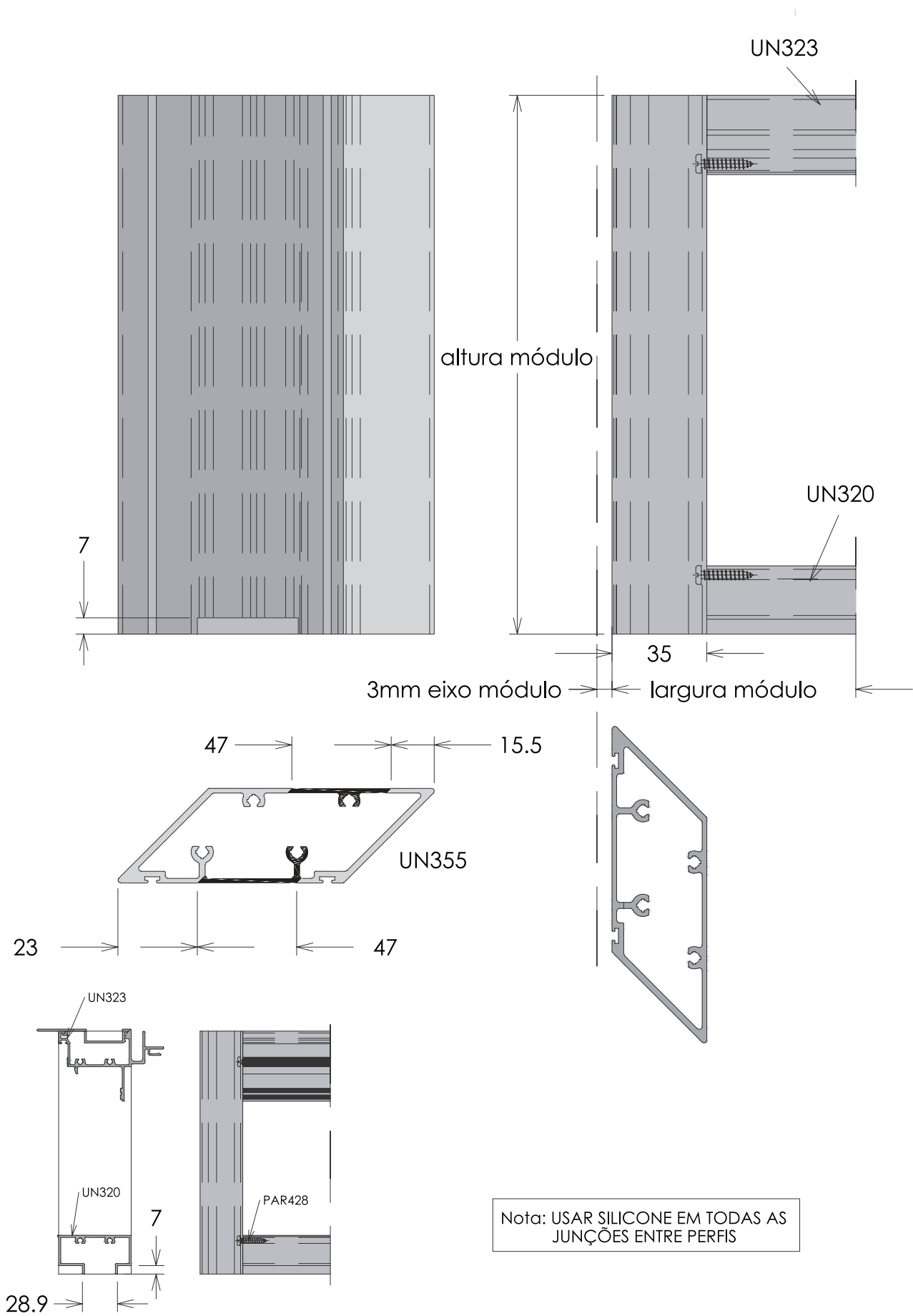

Módulo 60-25

CANTO NEGATIVO

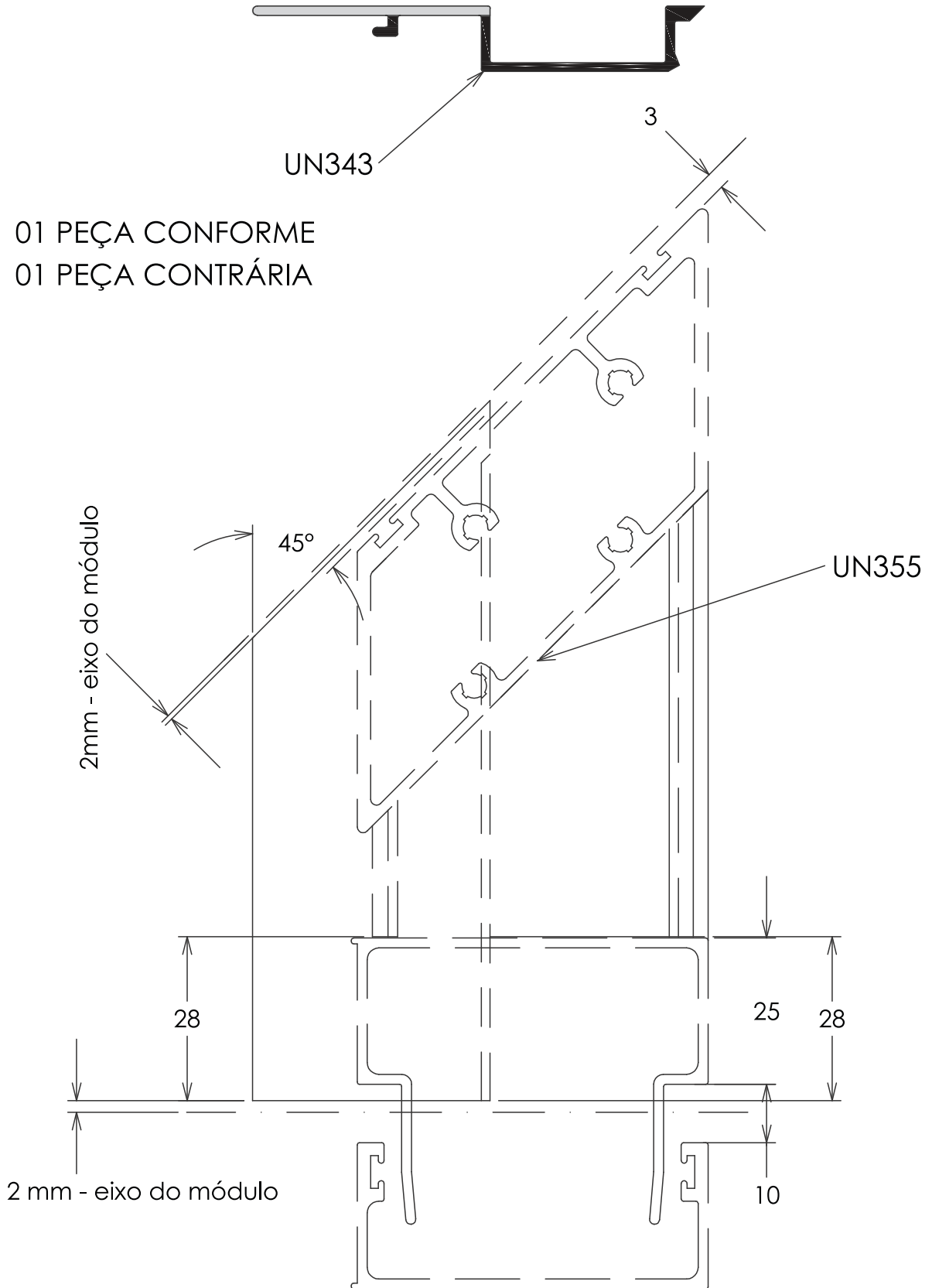

Módulo 60-25

CANTO POSITIVO

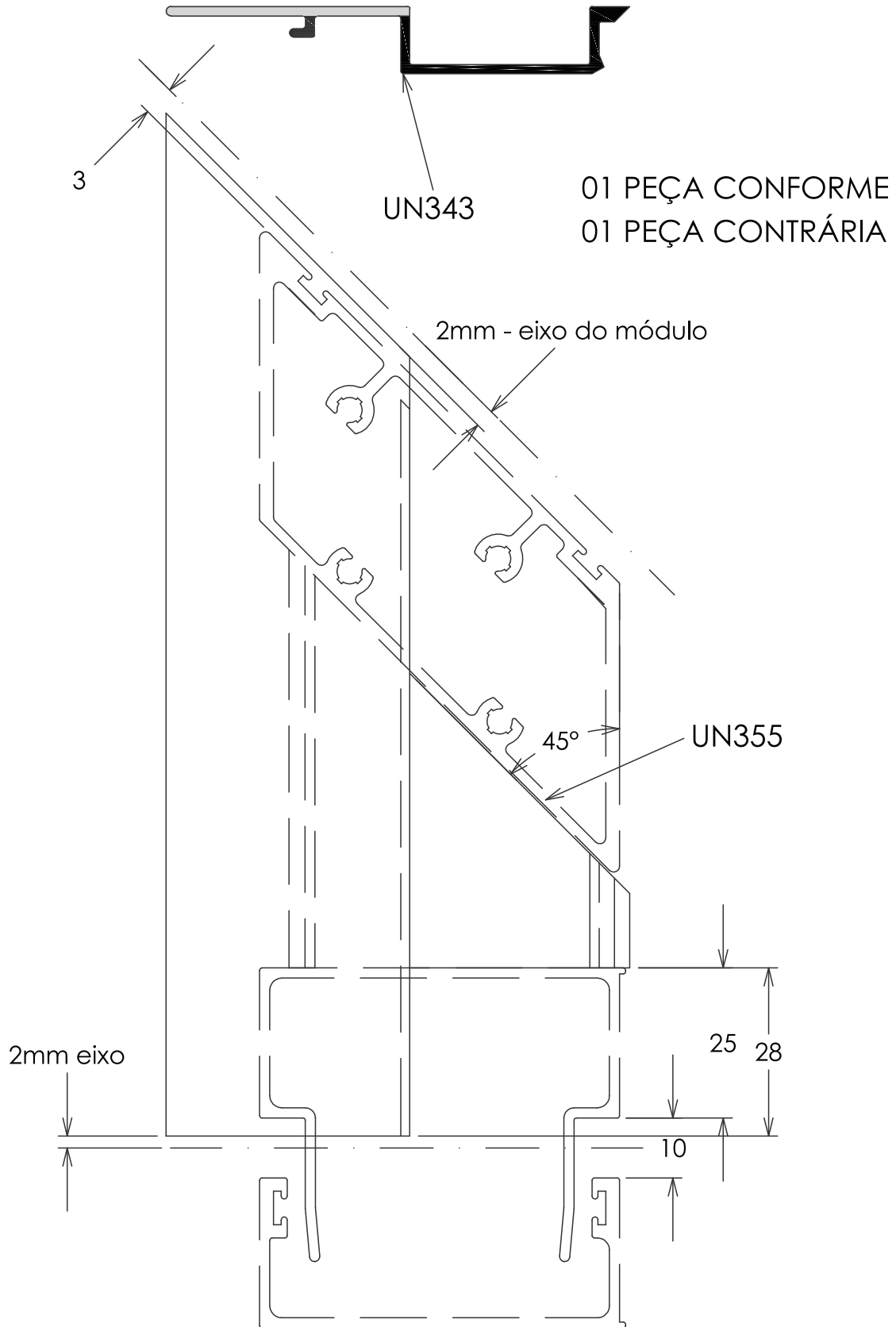

Módulo 60-25

CANTO POSITIVO

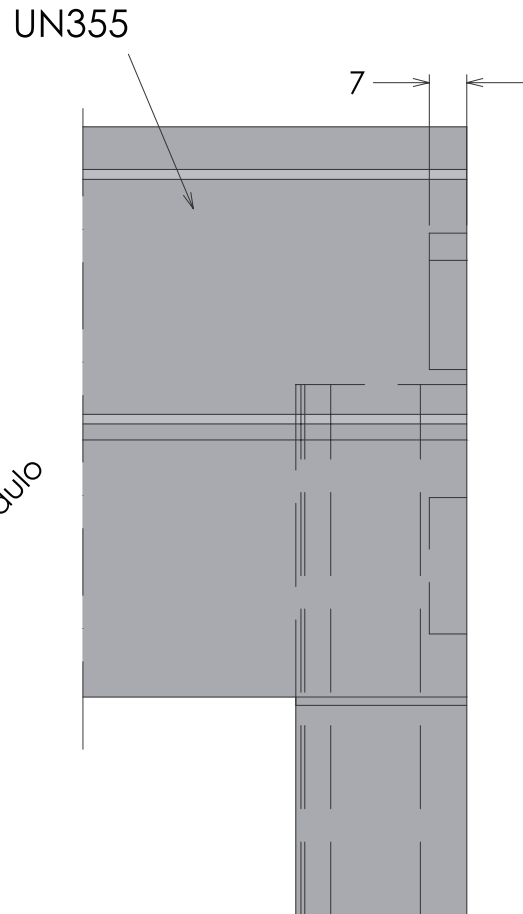
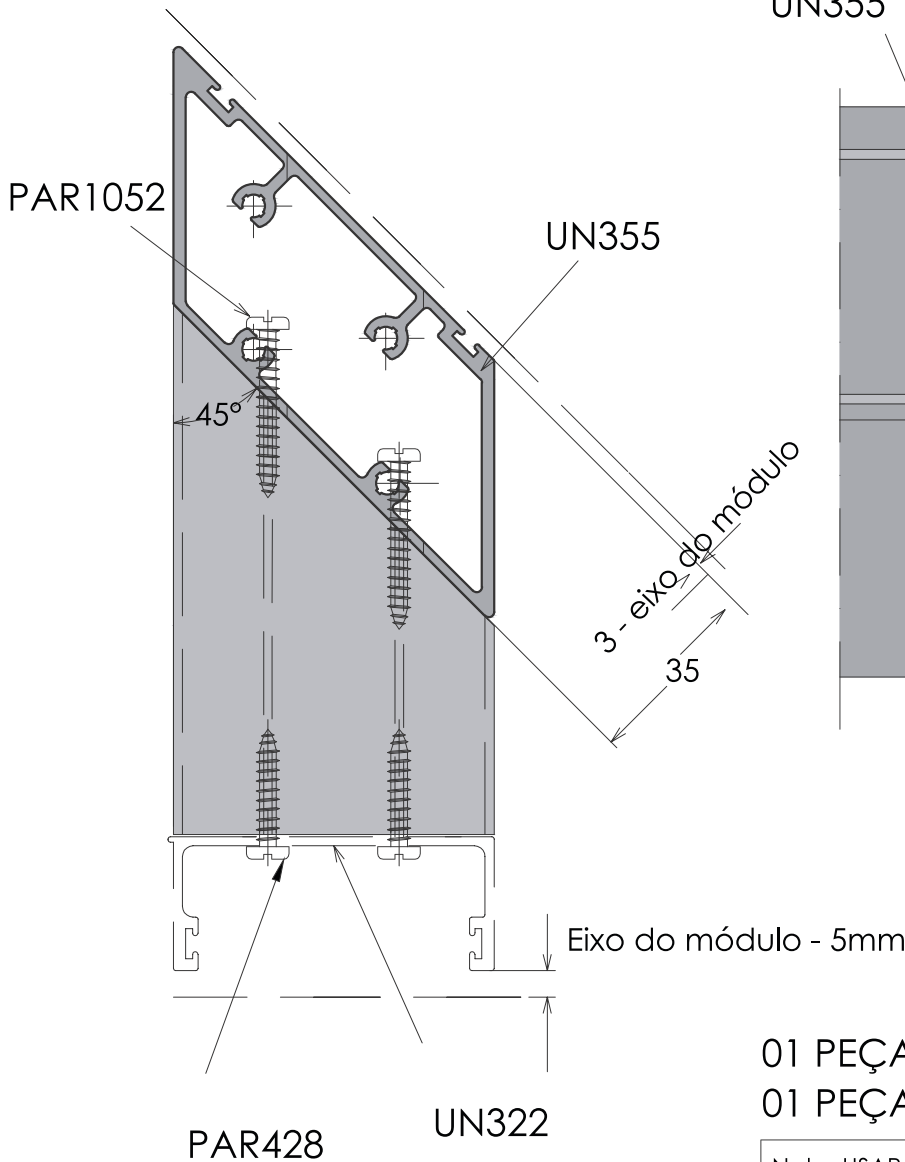
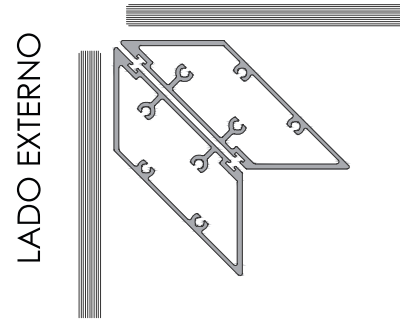
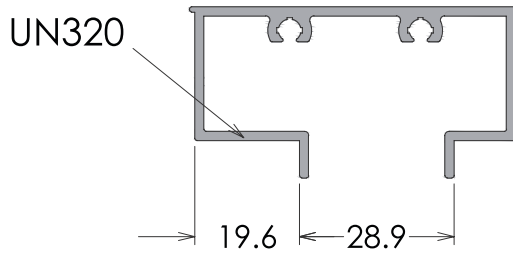

01 PEÇA CONFORME
01 PEÇA CONTRÁRIA

Nota: USAR SILICONE EM TODAS AS
JUNÇÕES ENTRE PERFIS

Módulo 60-25

CANTO POSITIVO

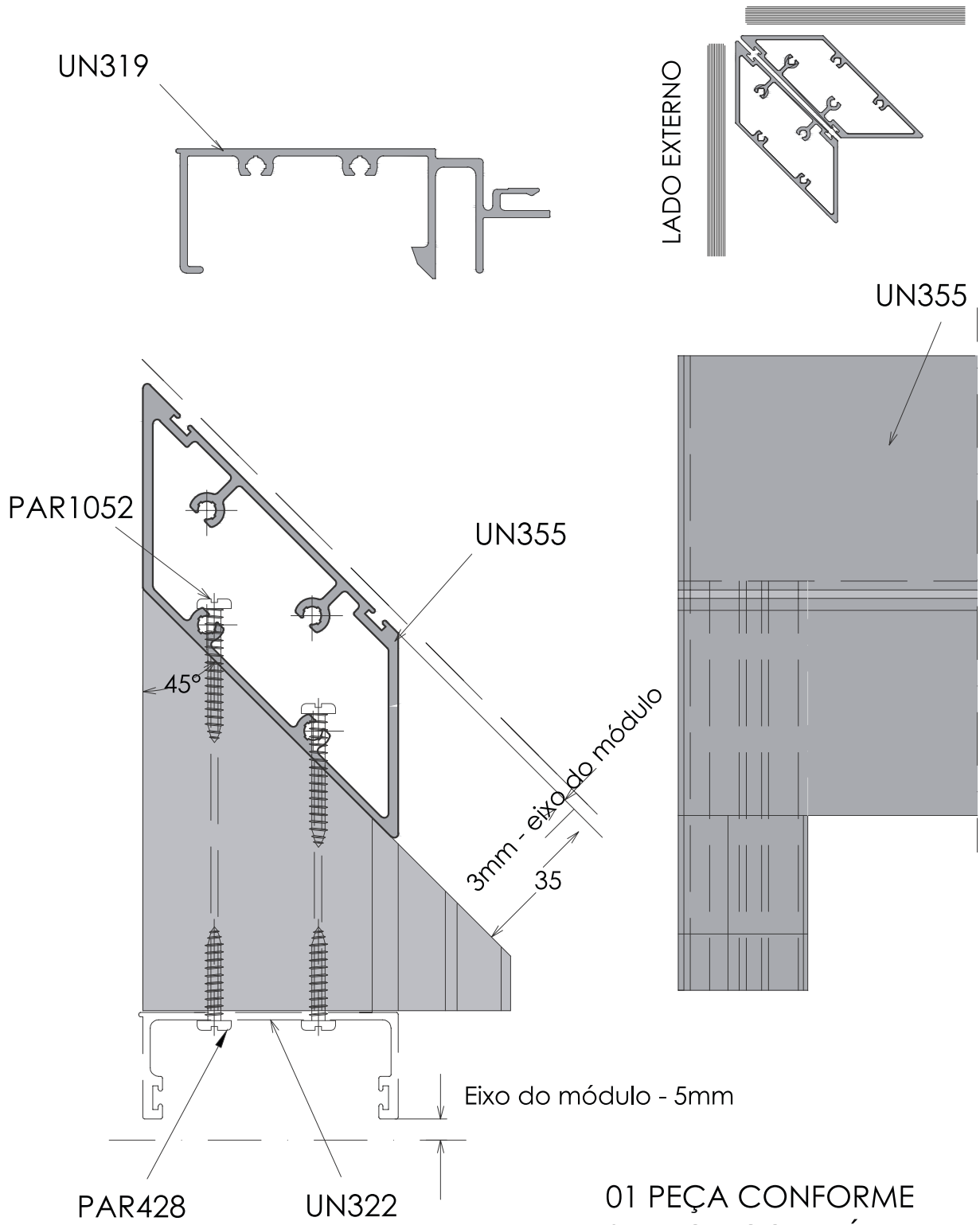

Nota: USAR SILICONE EM TODAS AS JUNÇÕES ENTRE PERFIS

Módulo 60-25

CANTO NEGATIVO

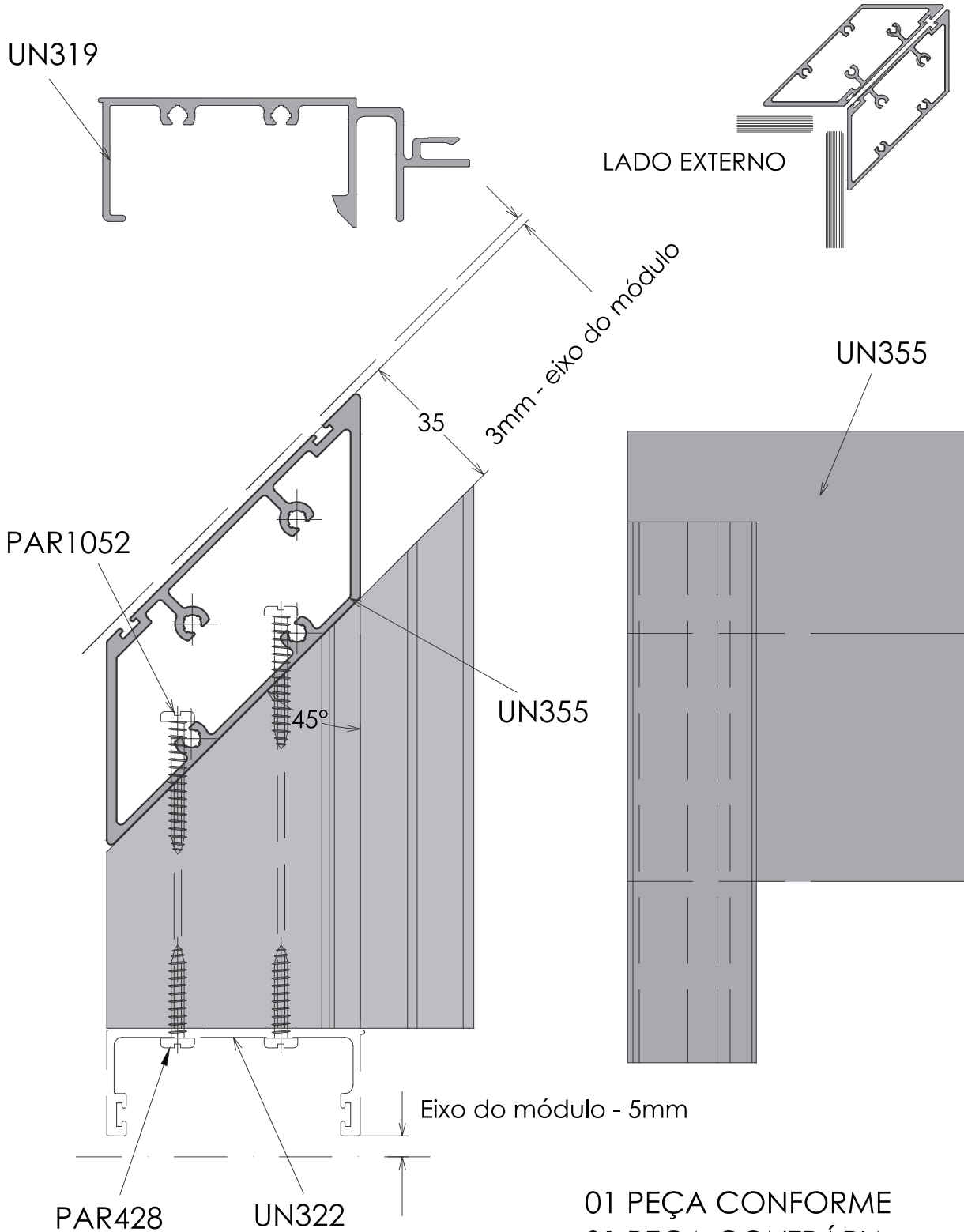

- 01 PEÇA CONFORME
- 01 PEÇA CONTRÁRIA

Nota: USAR SILICONE EM TODAS AS JUNÇÕES ENTRE PERFIS

Módulo 60-25

CANTO NEGATIVO

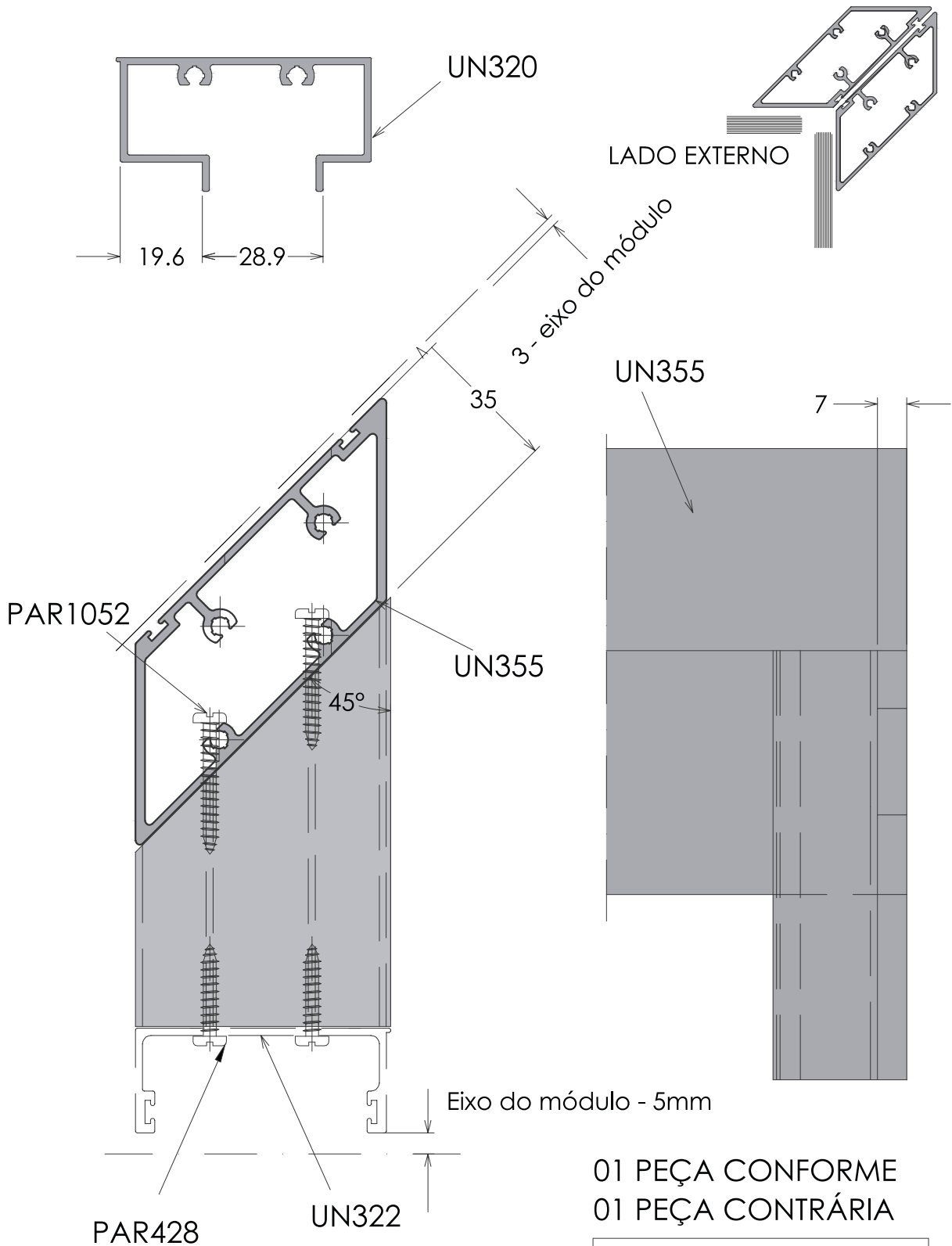

Nota: USAR SILICONE EM TODAS AS JUNÇÕES ENTRE PERFIS

Módulo 80-25

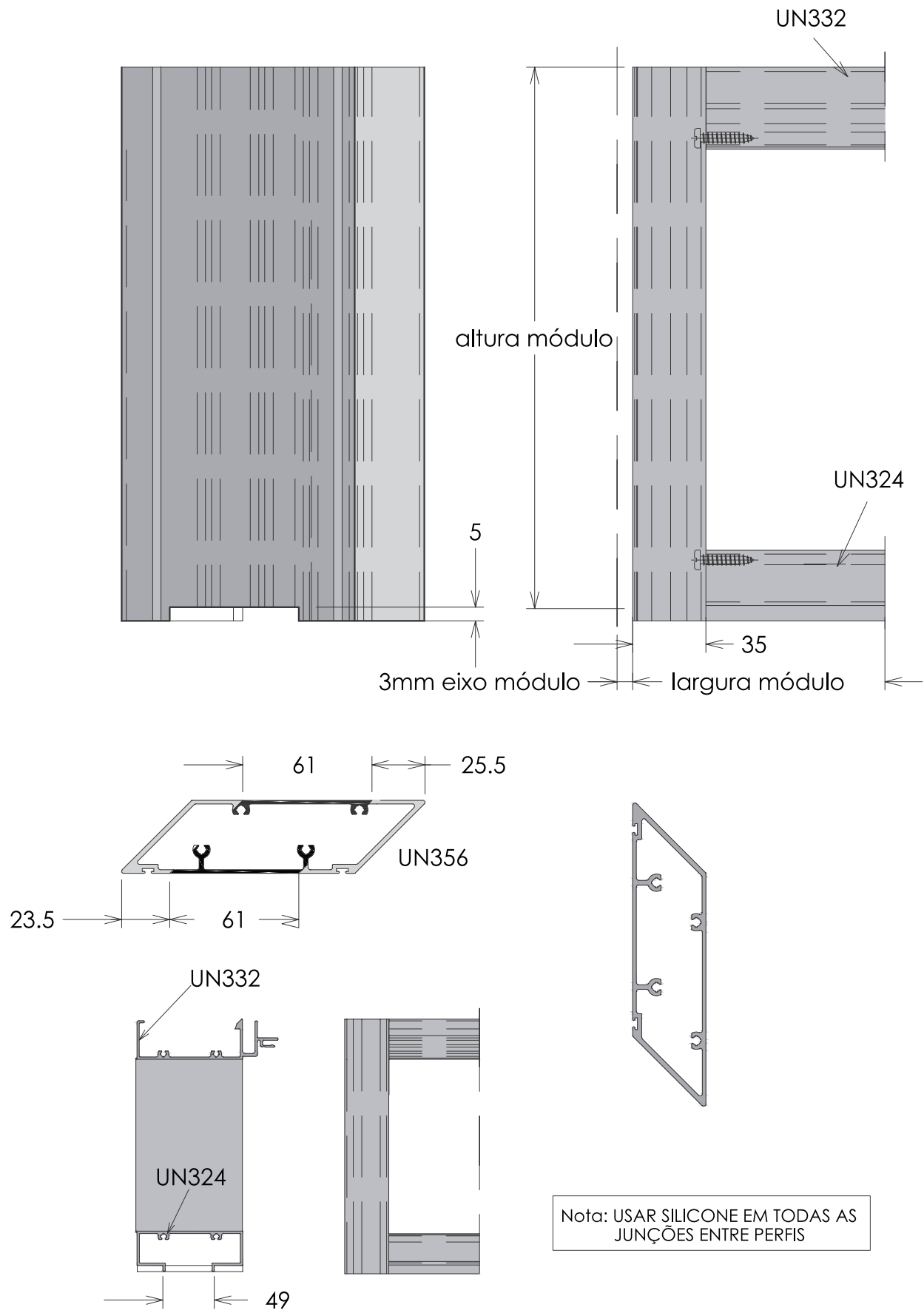

Módulo 80-25

CANTO NEGATIVO

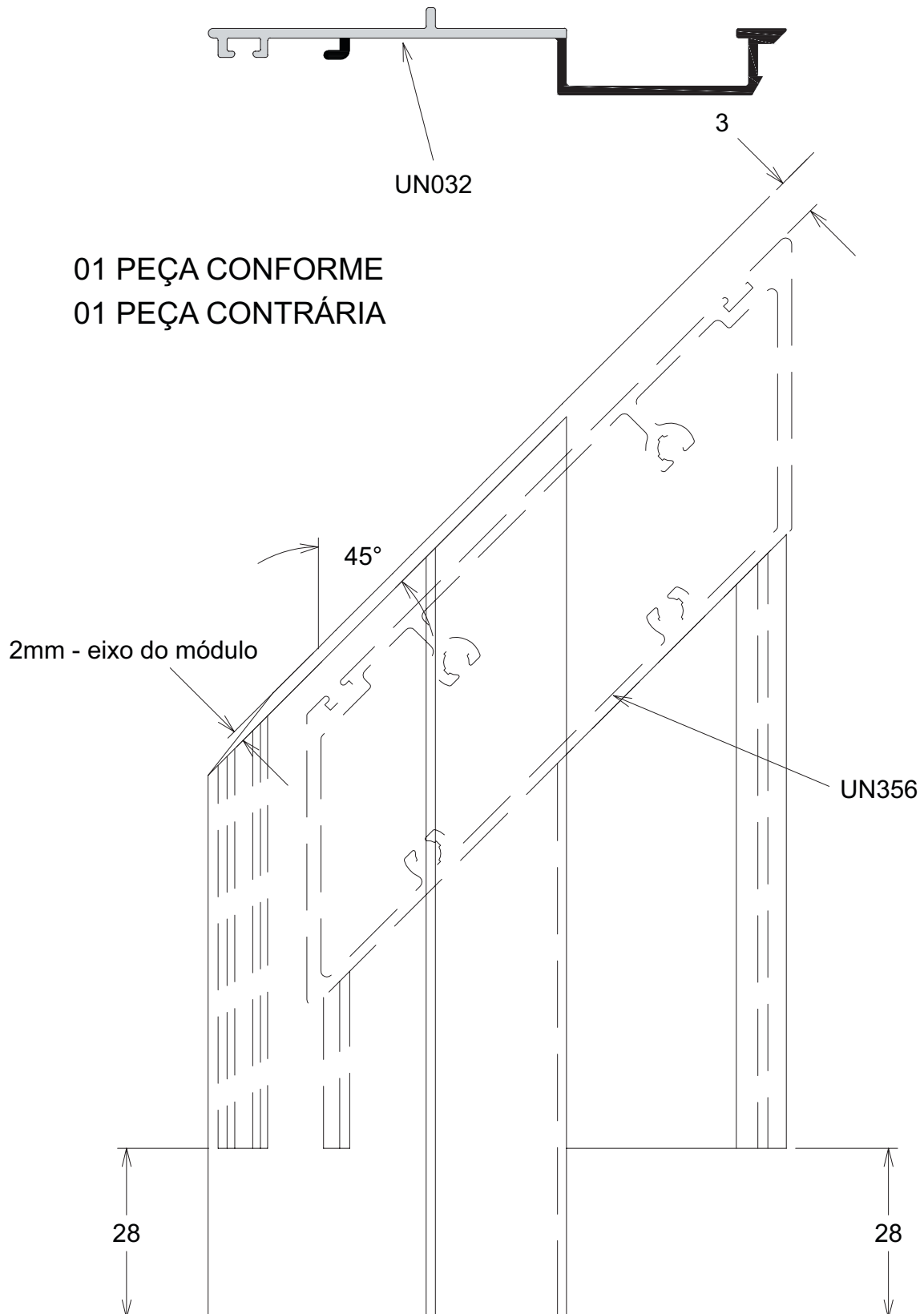

Módulo 80-25

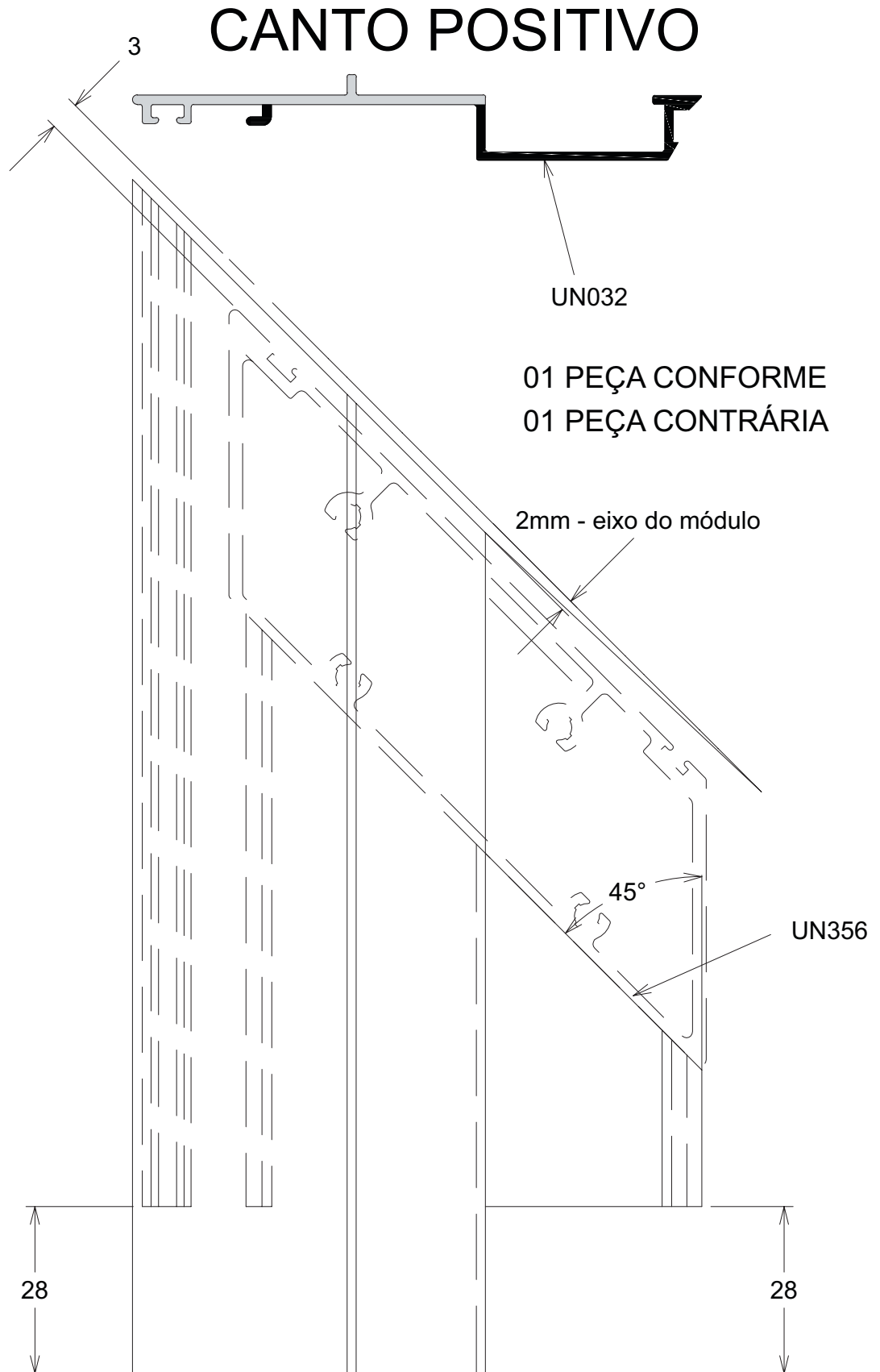

Módulo 80-25

CANTO NEGATIVO

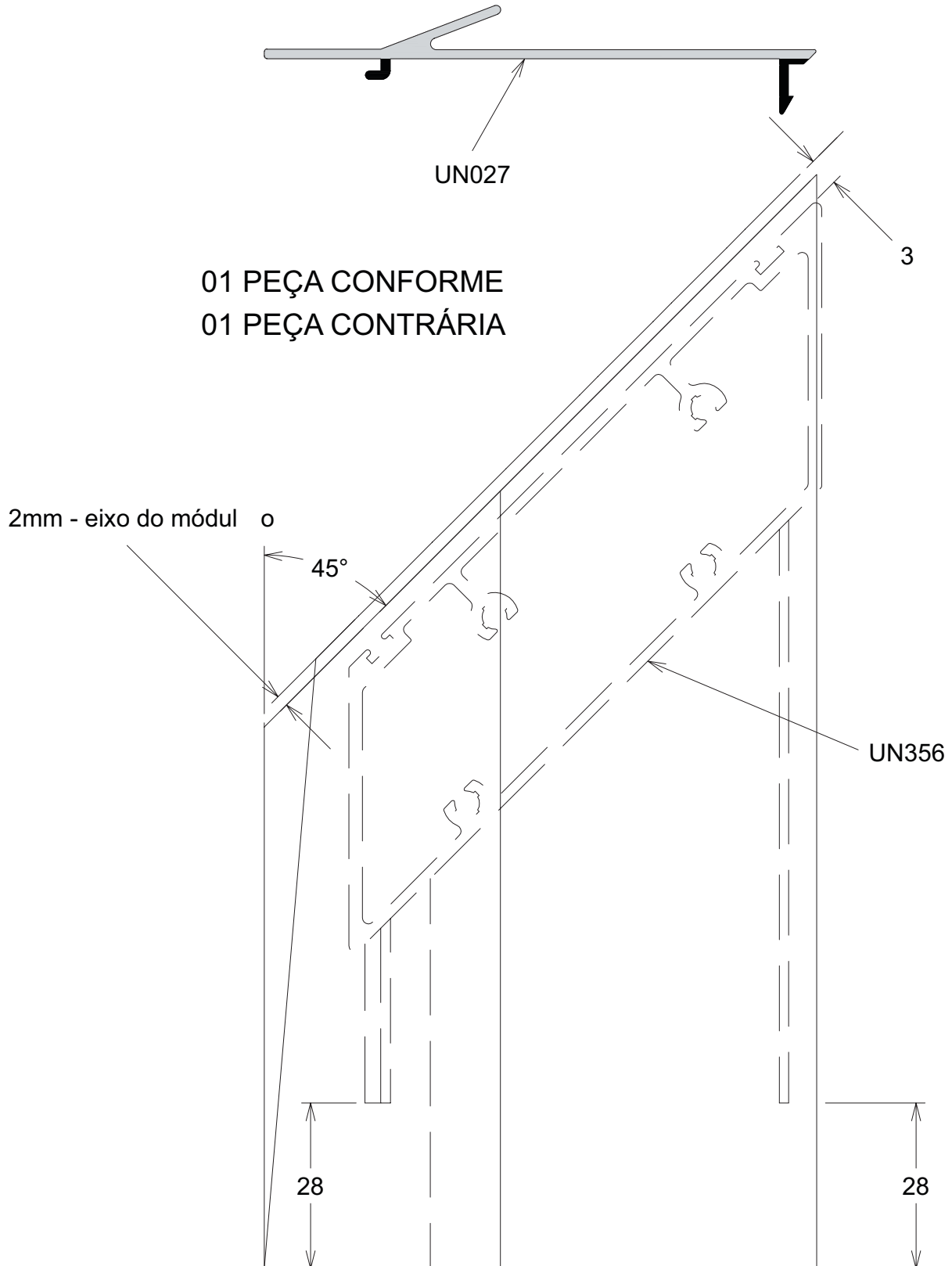

Módulo 80-25

CANTO POSITIVO

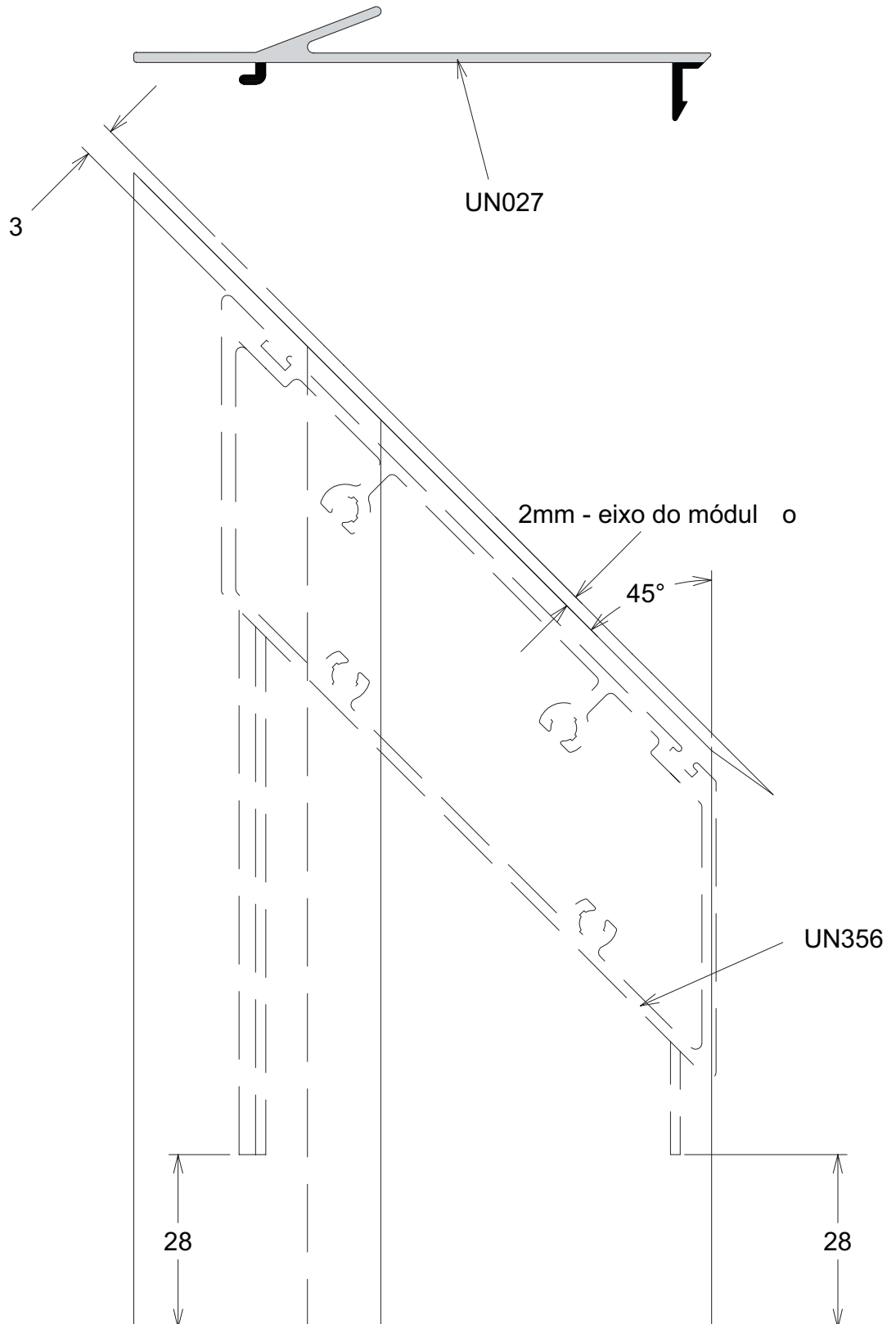

Módulo 80-25

CANTO POSITIVO

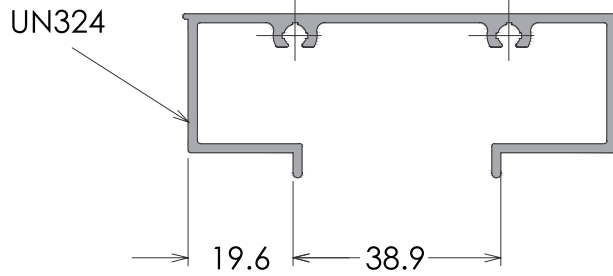

LADO EXTERNO

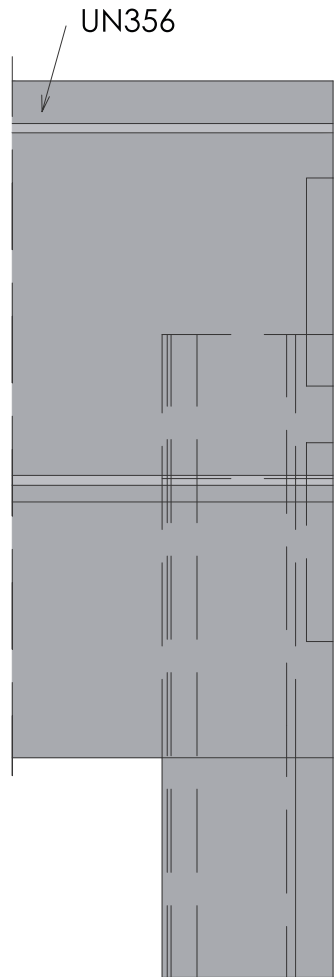
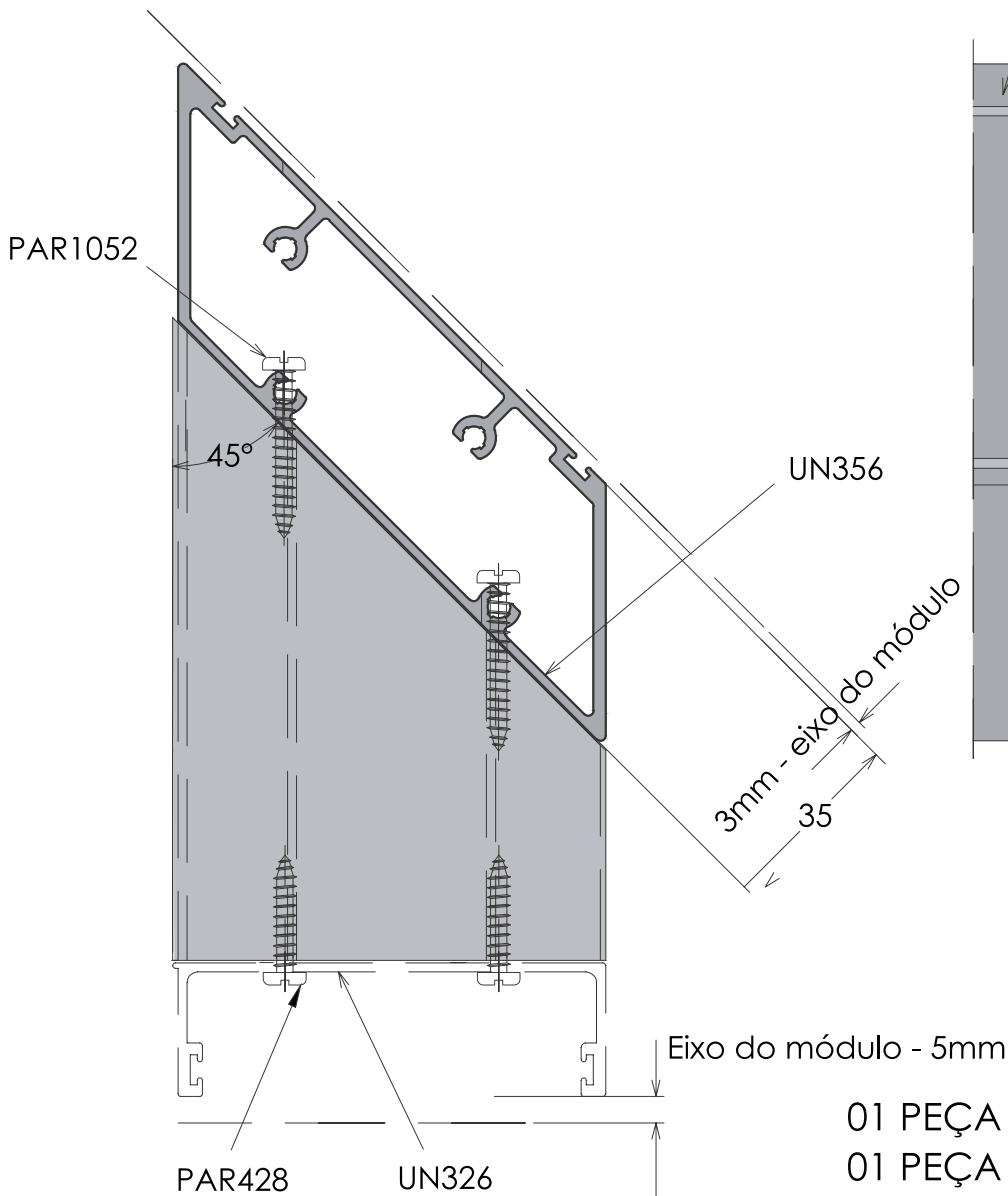
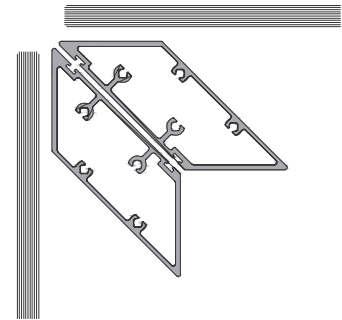

01 PEÇA CONFORME
01 PEÇA CONTRÁRIA

Nota: USAR SILICONE EM TODAS AS JUNÇÕES ENTRE PERFIS

Módulo 80-25

CANTO NEGATIVO

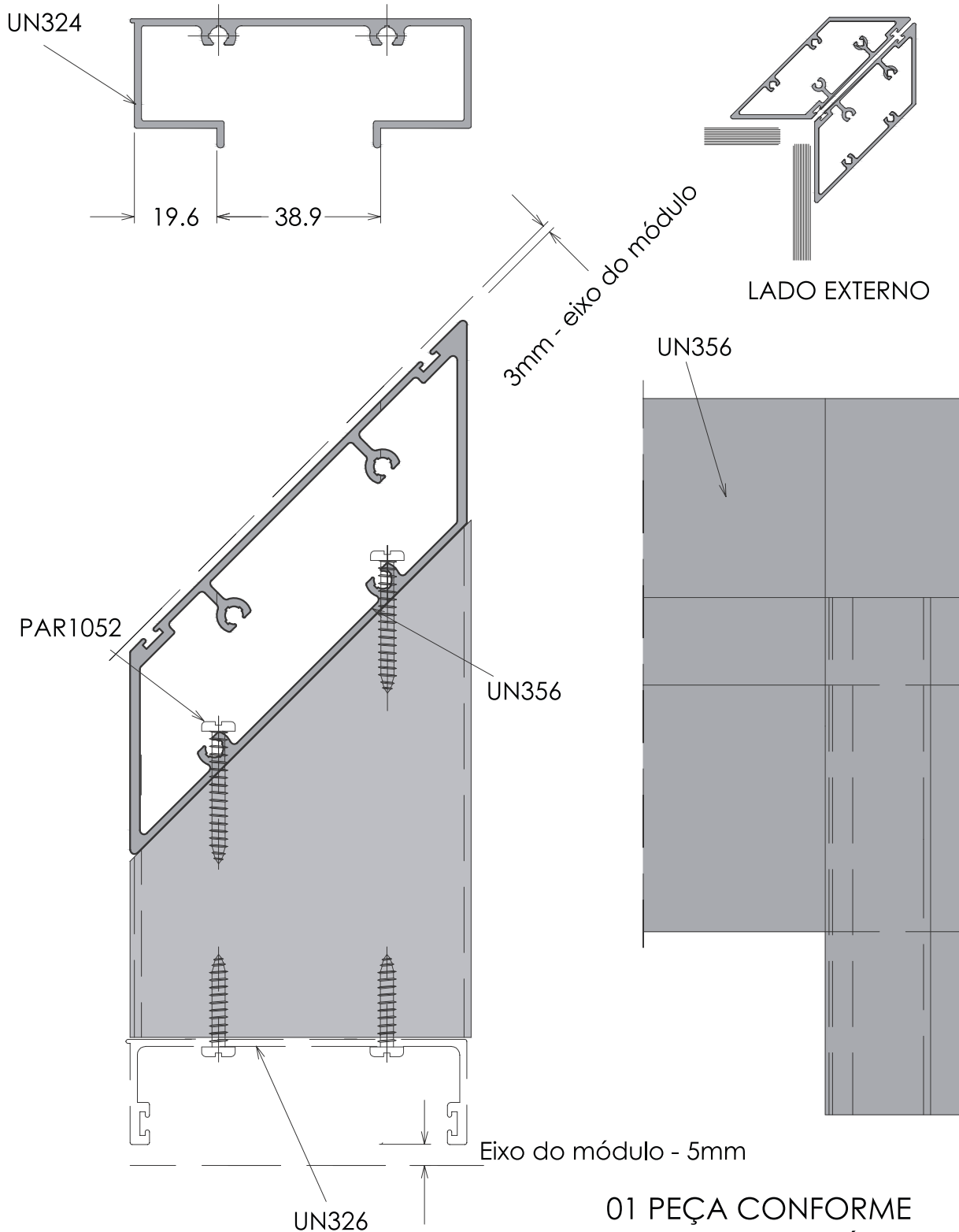

01 PEÇA CONFORME
01 PEÇA CONTRÁRIA

Nota: USAR SILICONE EM TODAS AS
JUNÇÕES ENTRE PERFIS

Módulo 80-25

CANTO POSITIVO

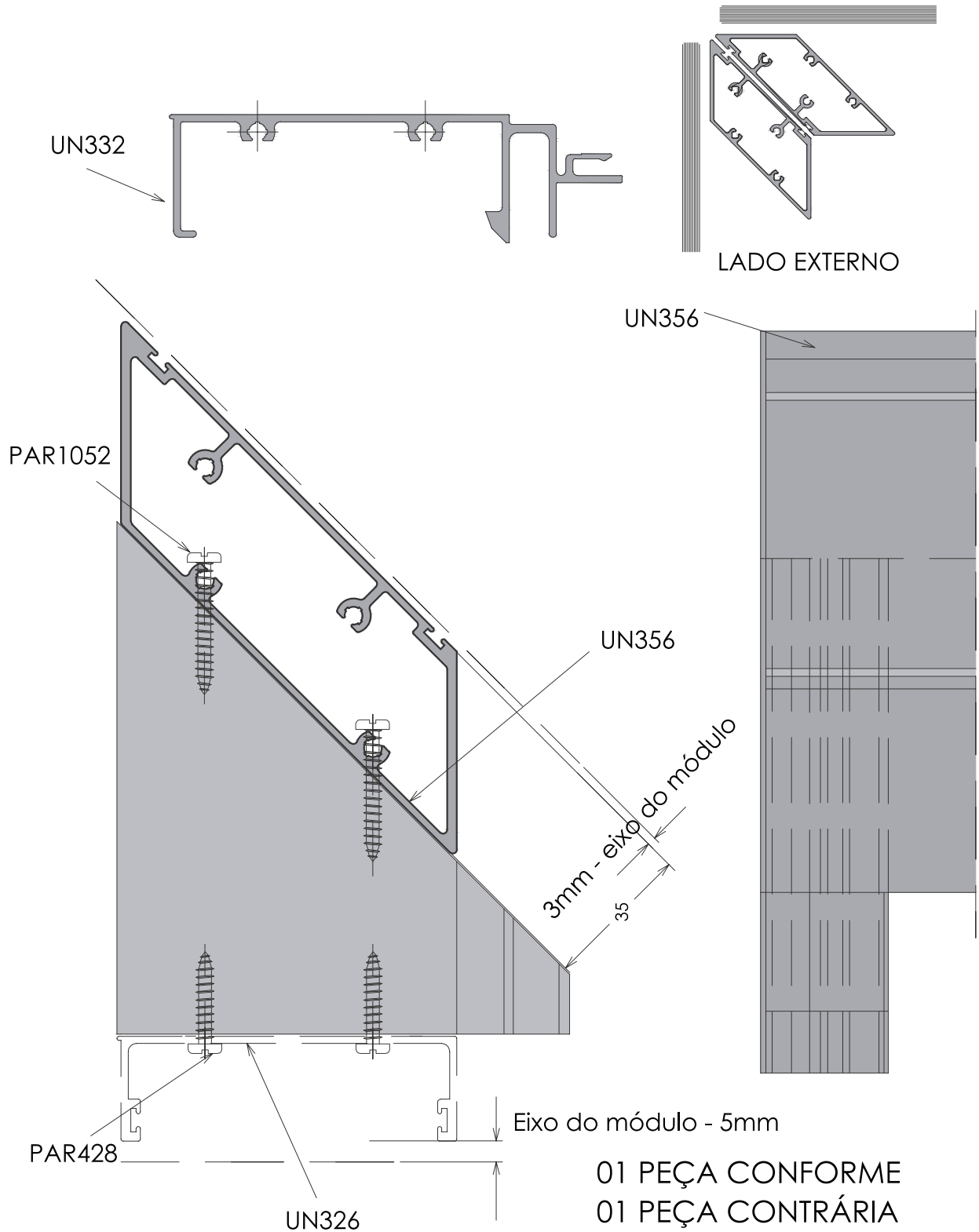

- 01 PEÇA CONFORME
- 01 PEÇA CONTRÁRIA

Nota: USAR SILICONE EM TODAS AS JUNÇÕES ENTRE PERFIS

Módulo 80-25

CANTO NEGATIVO

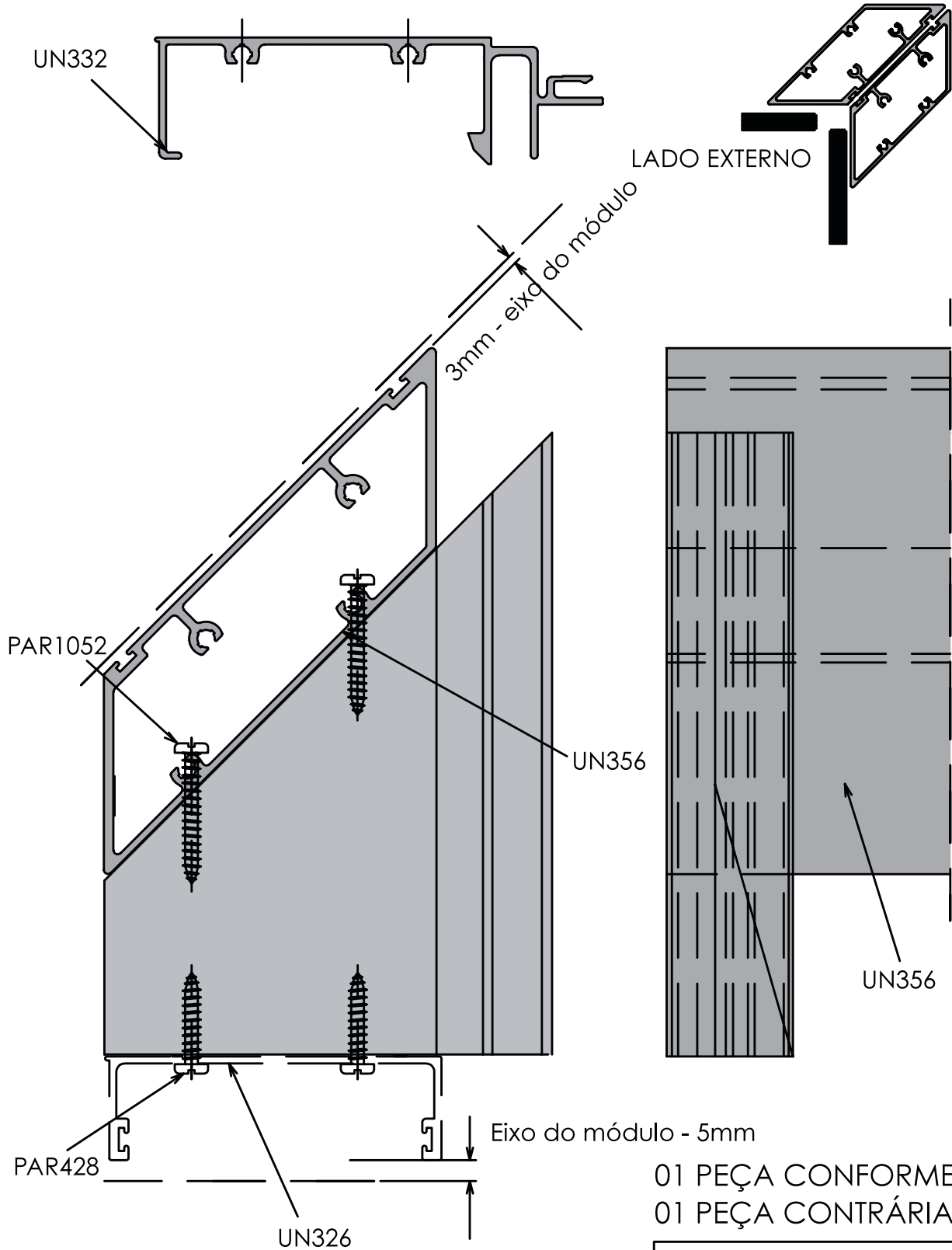

Nota: USAR SILICONE EM TODAS AS JUNÇÕES ENTRE PERFIS

Módulo 80-35 Rebaixo

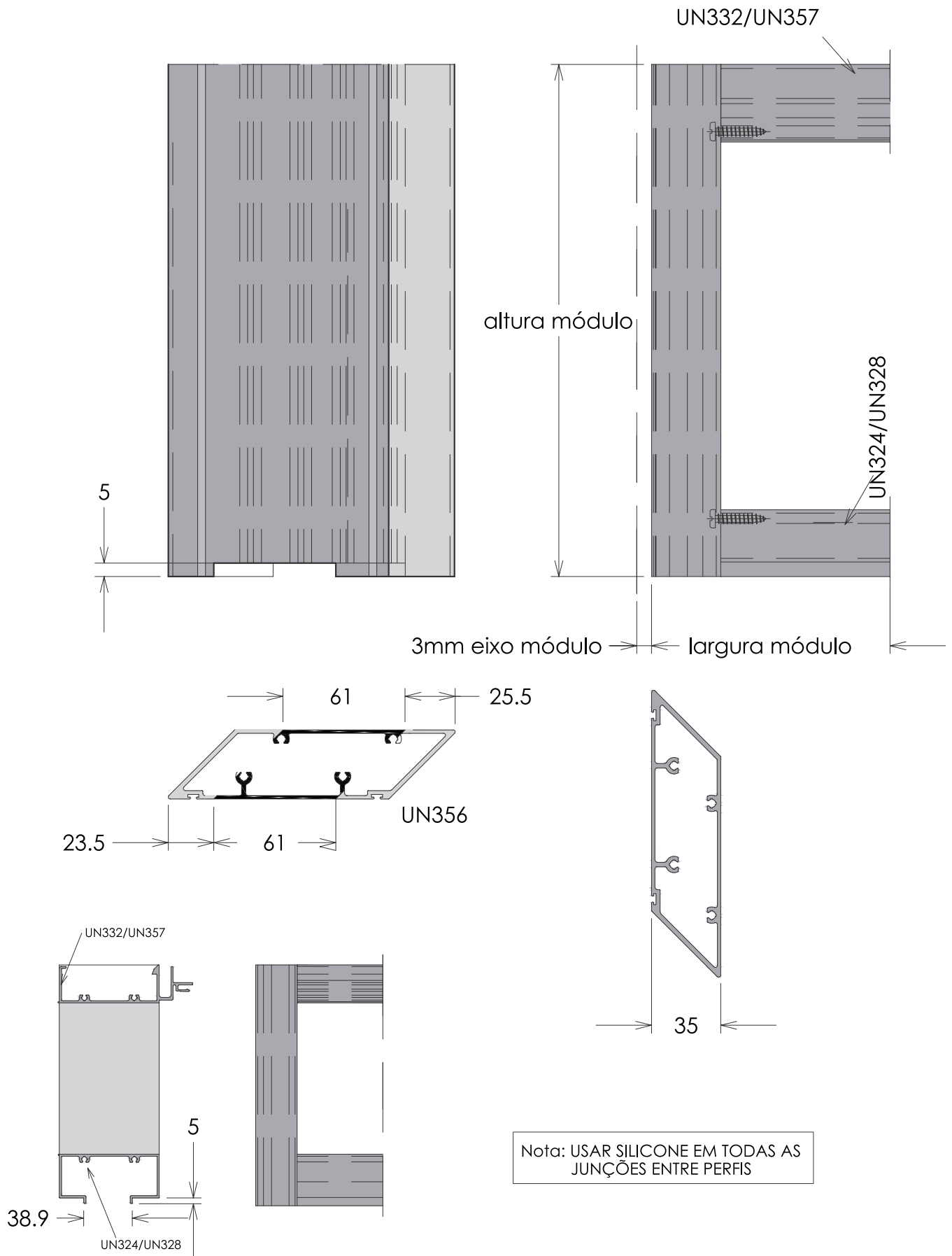

Nota: USAR SILICONE EM TODAS AS JUNÇÕES ENTRE PERFIS

Módulo 80-35 Rebaixo

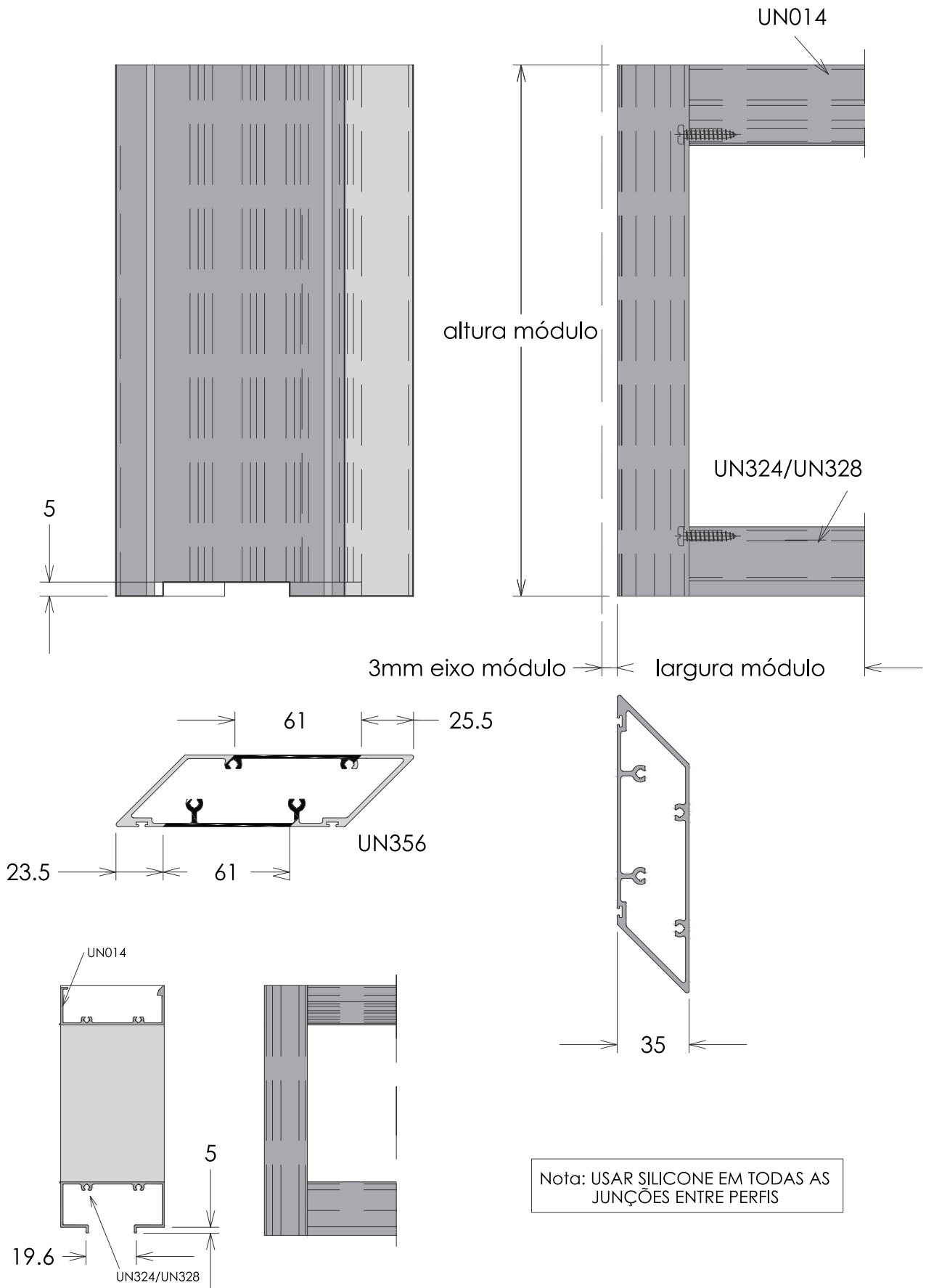

Módulo 80-35 Rebaixo

CANTO POSITIVO

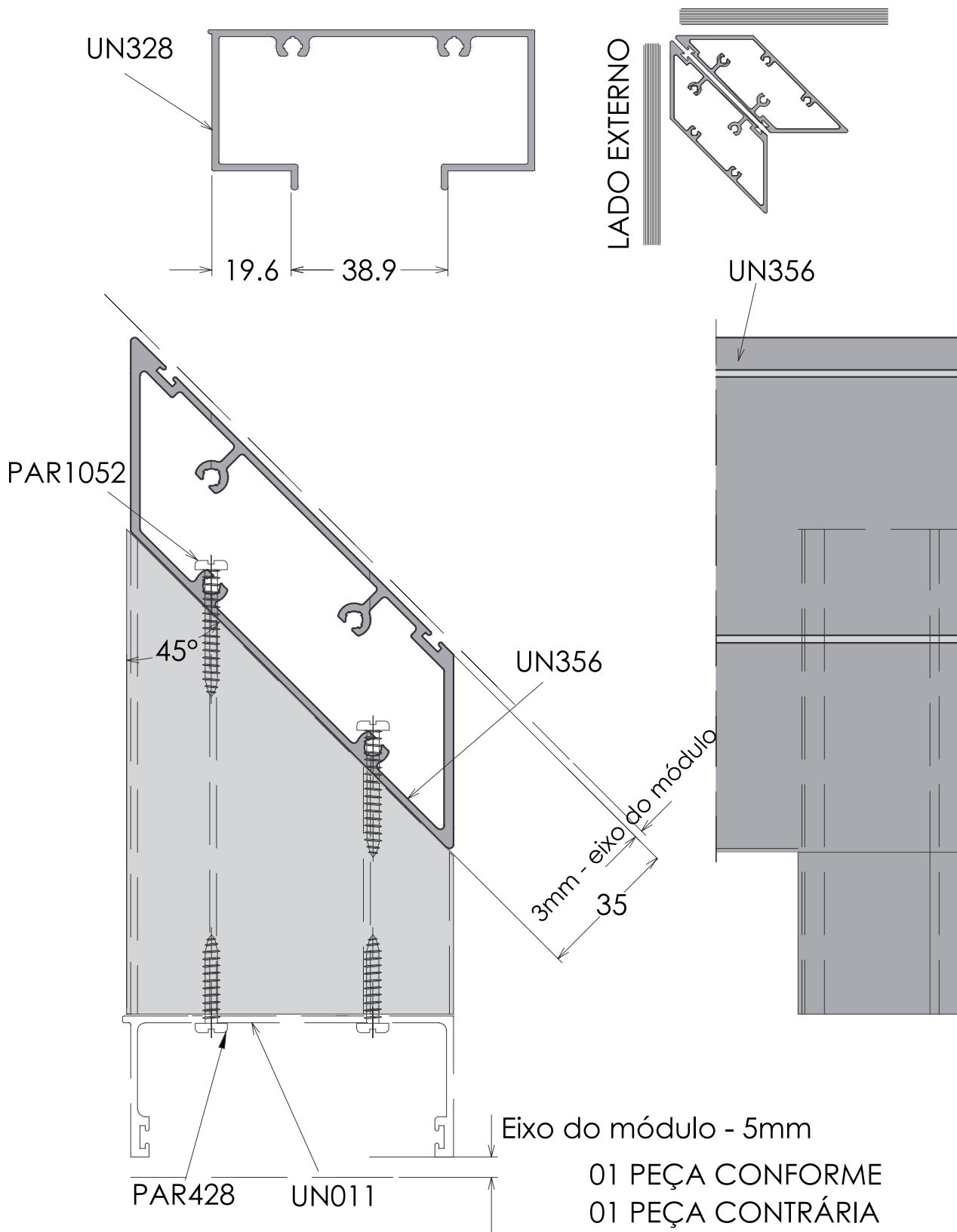

Módulo 80-35 Rebaixo

CANTO NEGATIVO

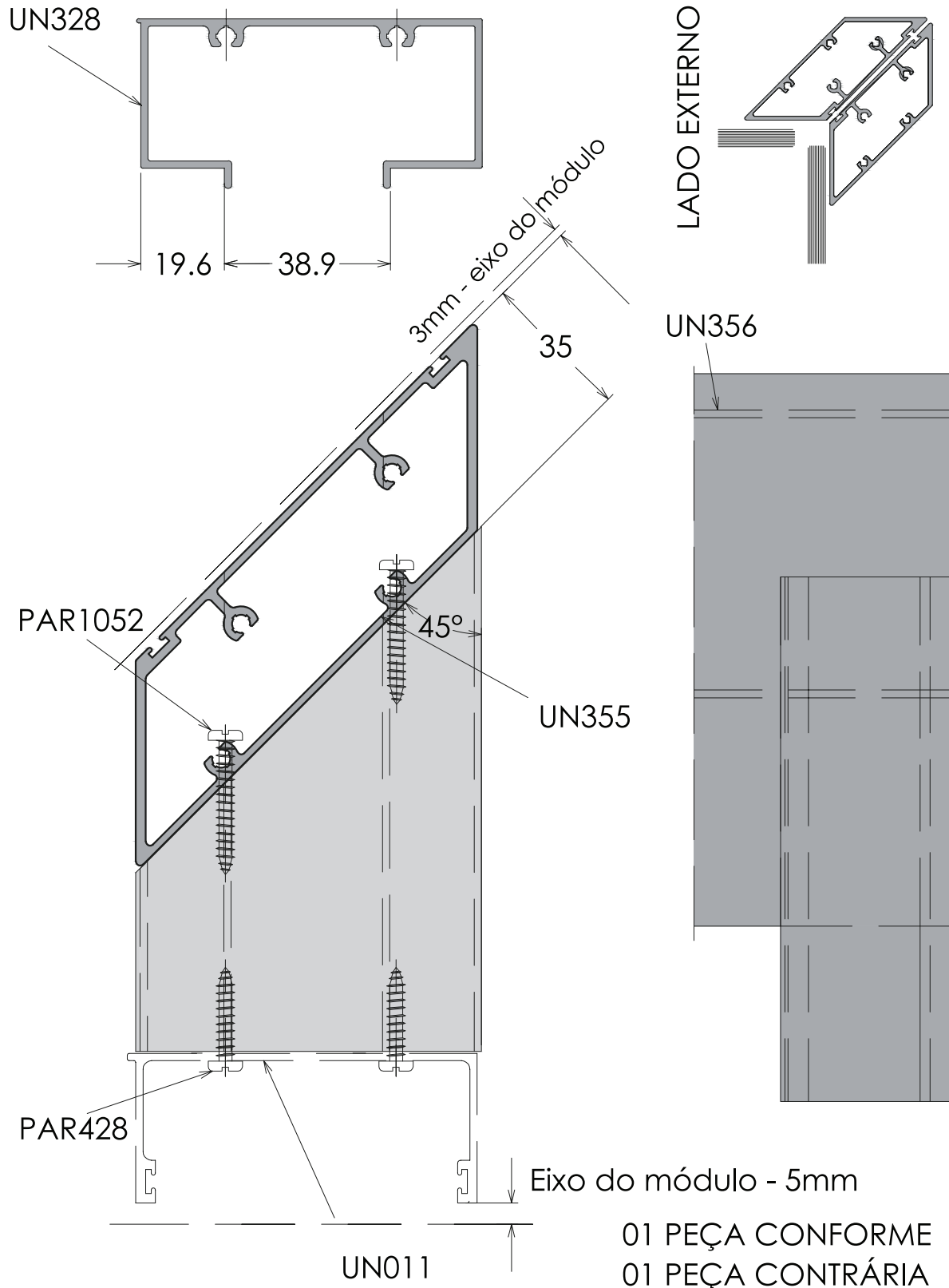

Nota: USAR SILICONE EM TODAS AS JUNÇÕES ENTRE PERFIS

Módulo 80-35 Rebaixo

CANTO POSITIVO

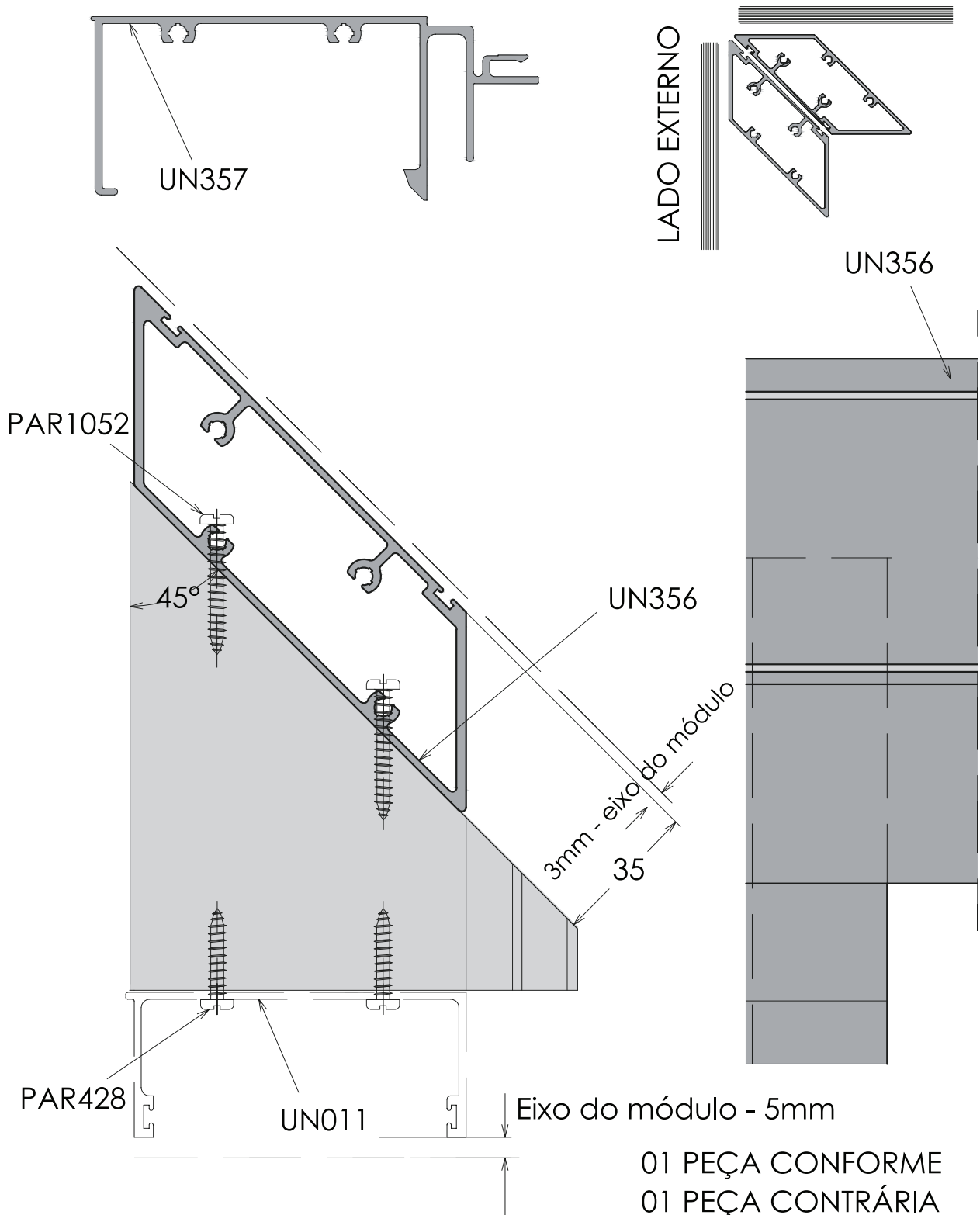

Nota: USAR SILICONE EM TODAS AS JUNÇÕES ENTRE PERFIS

Módulo 80-35 Rebaixo

CANTO NEGATIVO

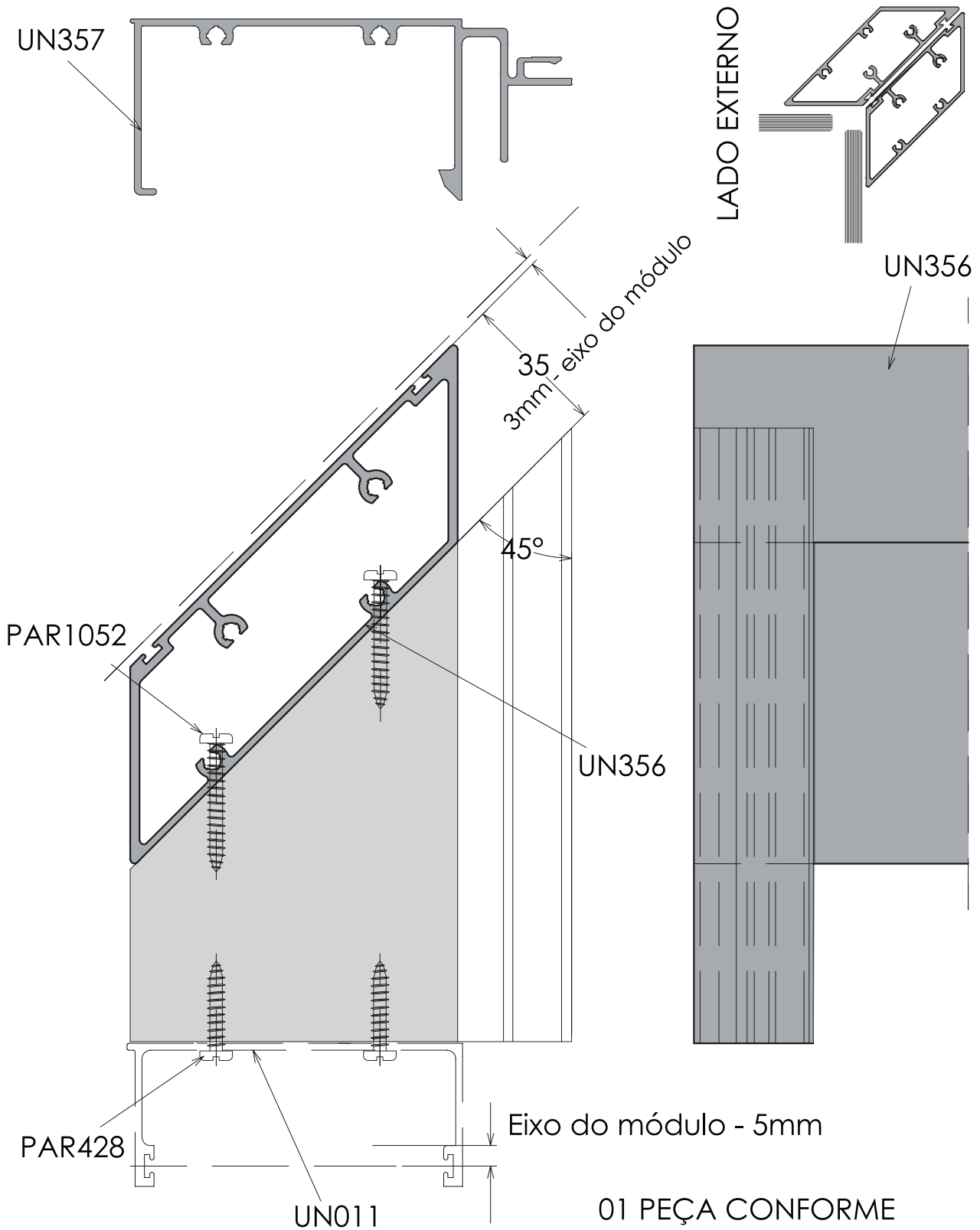

01 PEÇA CONFORME
01 PEÇA CONTRÁRIA

Nota: USAR SILICONE EM TODAS AS
JUNÇÕES ENTRE PERFIS

Módulo 80-35R

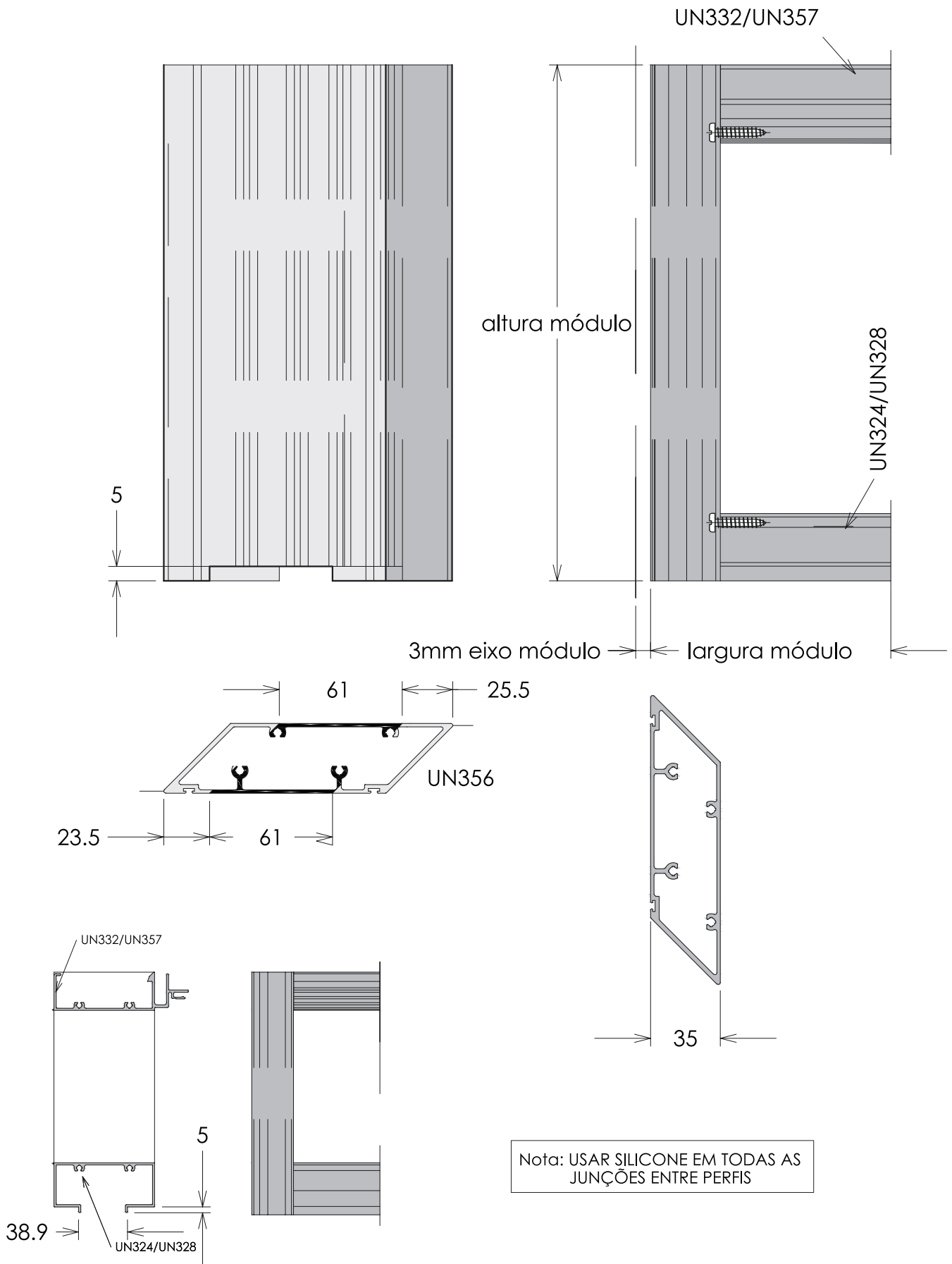

Módulo 80-35R

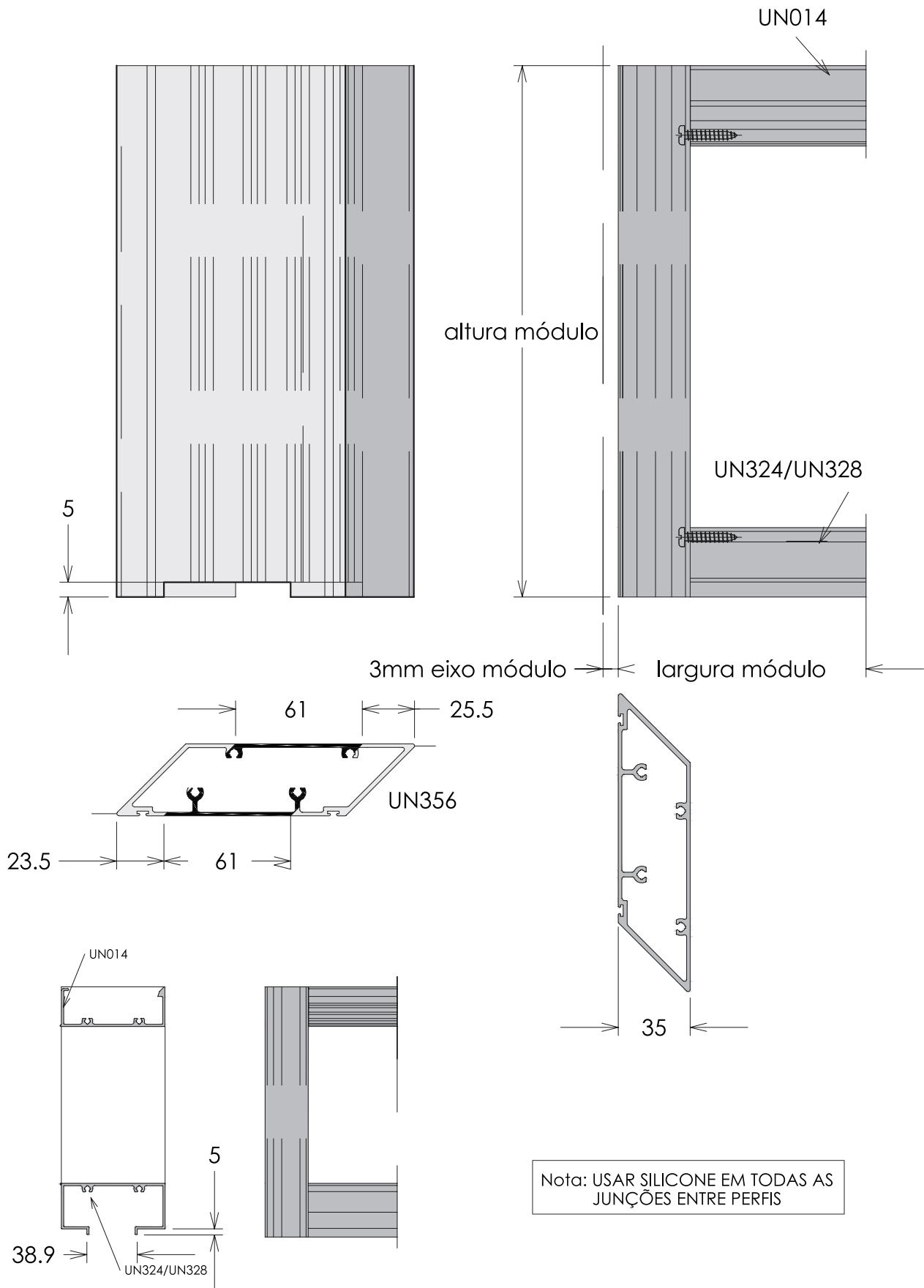

Módulo 80-35R

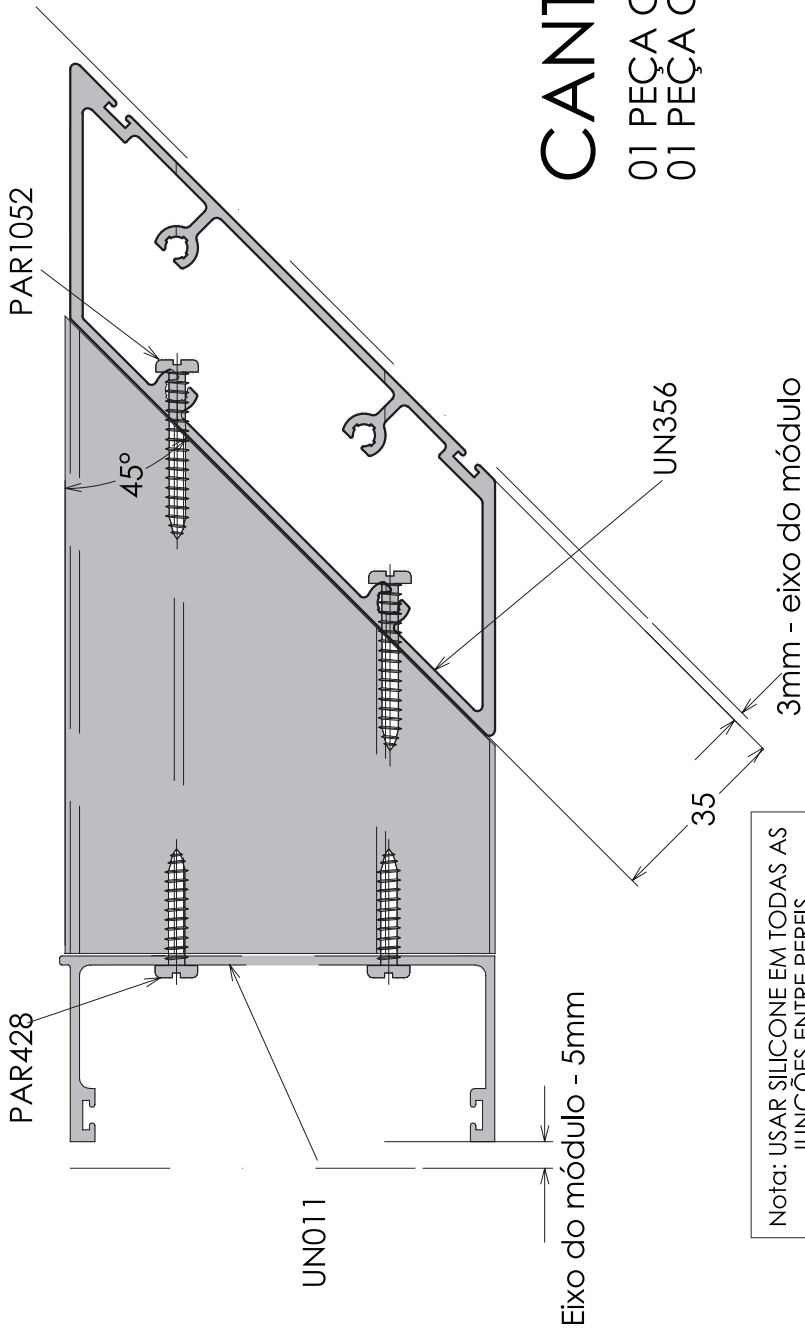
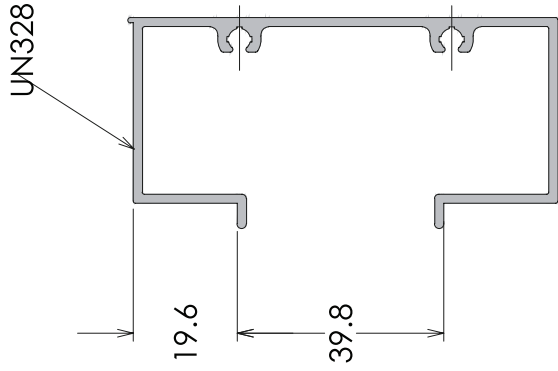

CANTO POSITIVO

01 PEÇA CONFORME
01 PEÇA CONTRÁRIA

LADO EXTERNO

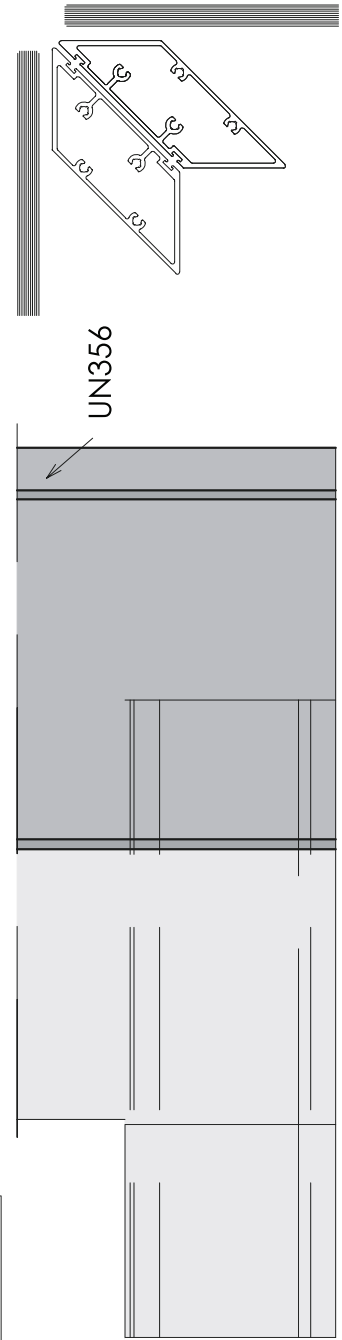

Nota: USAR SILICONE EM TODAS AS JUNÇÕES ENTRE PERFIS

Módulo 80-35R

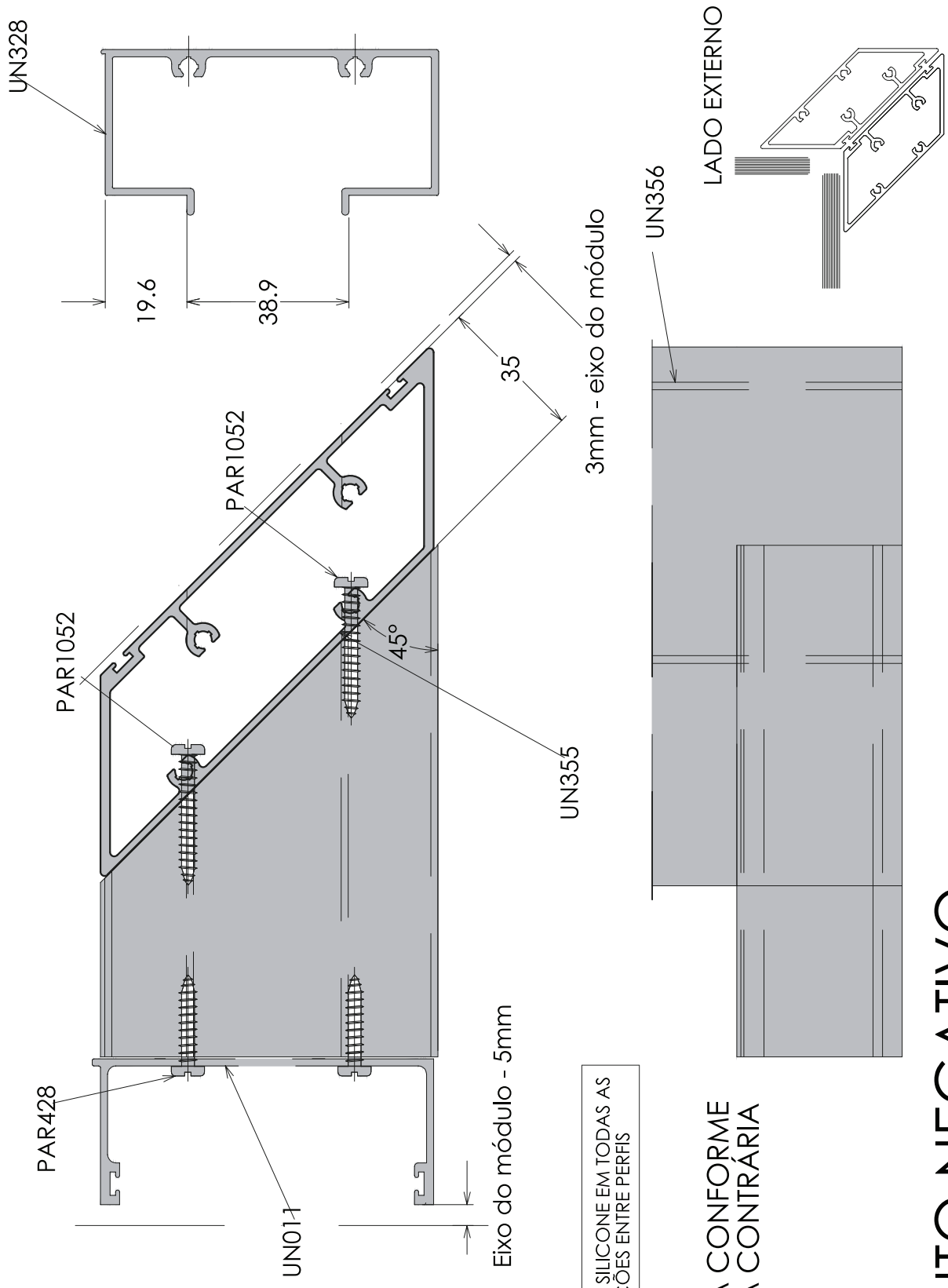

Nota: USAR SILICONE EM TODAS AS JUNÇÕES ENTRE PERFIS

- 01 PEÇA CONFORME
- 01 PEÇA CONTRÁRIA

CANTO NEGATIVO

Módulo 80-35R

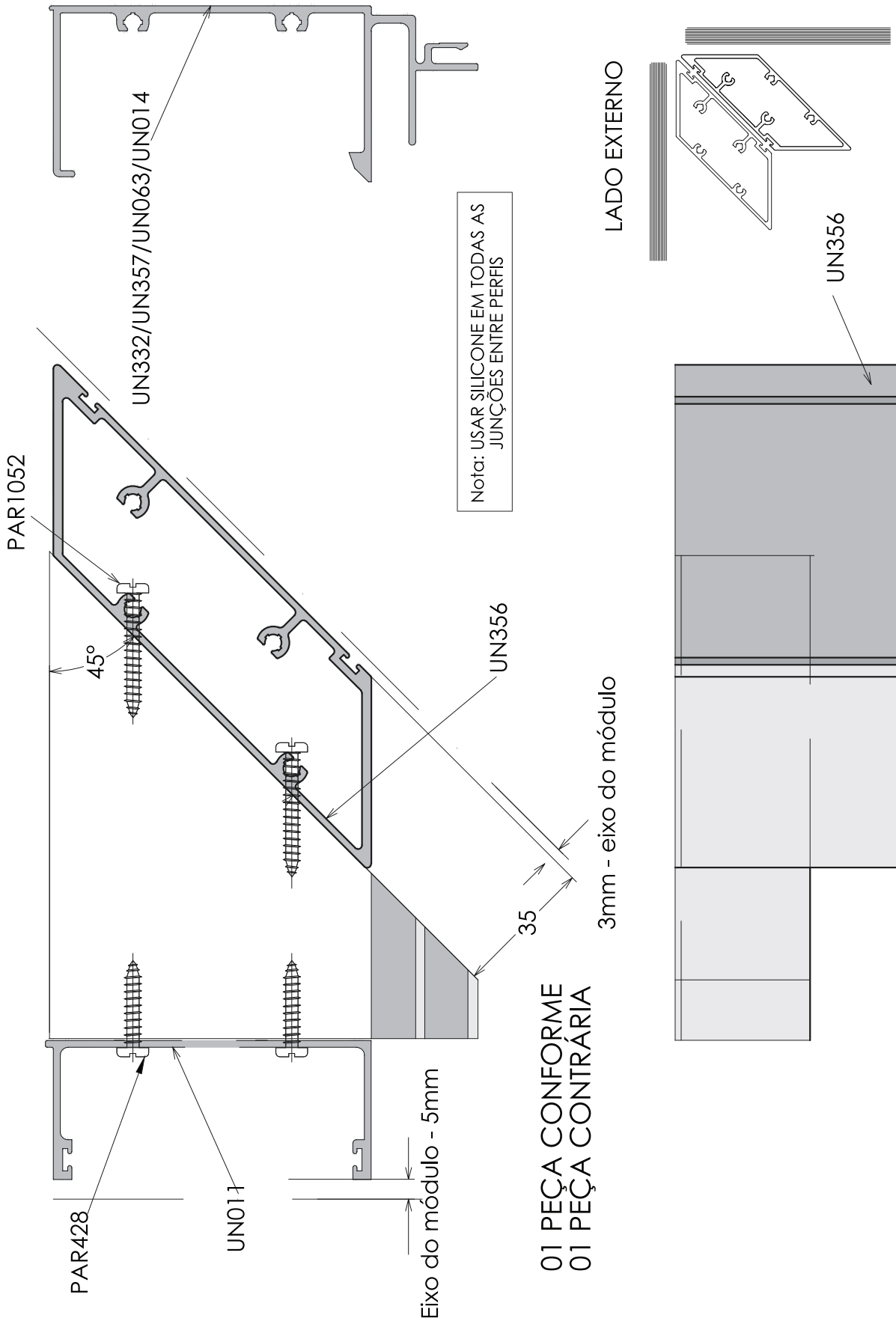

Módulo 80-35R

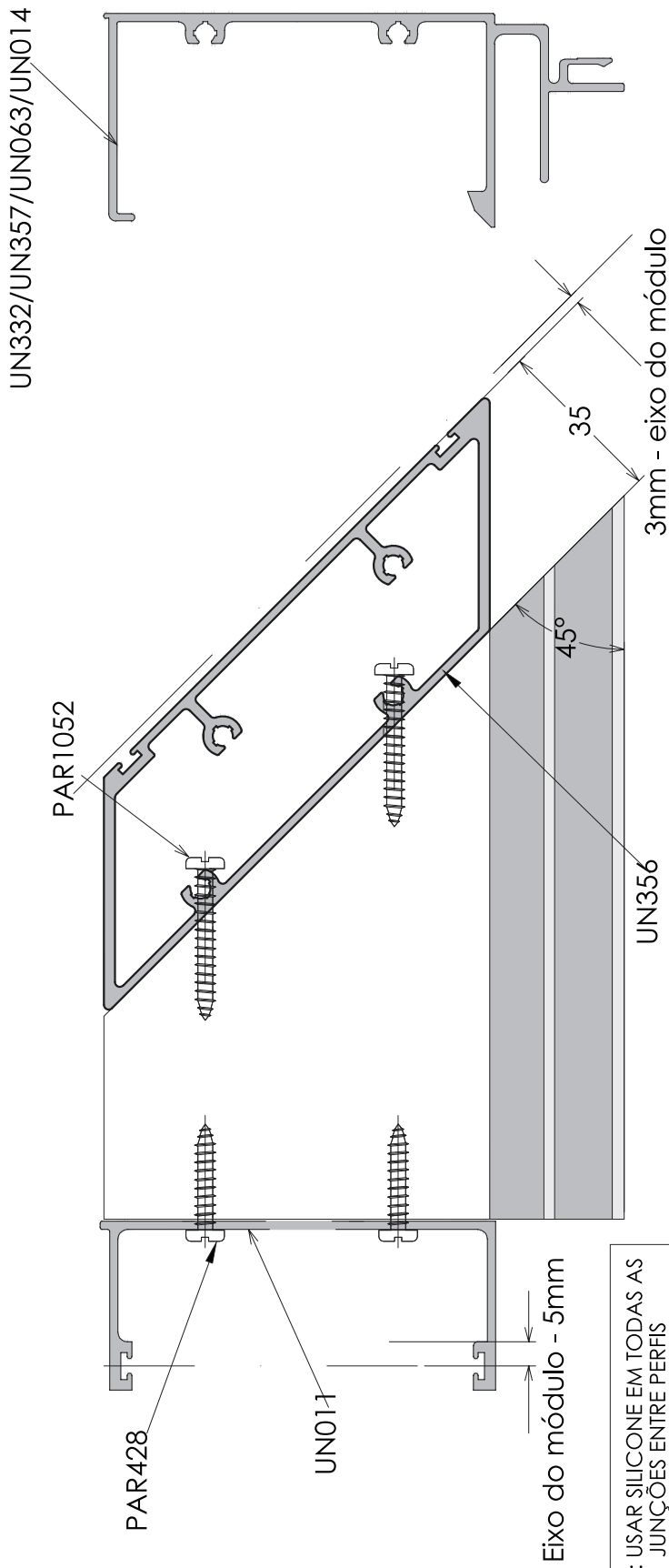

01 PEÇA CONFORME
01 PEÇA CONTRÁRIA

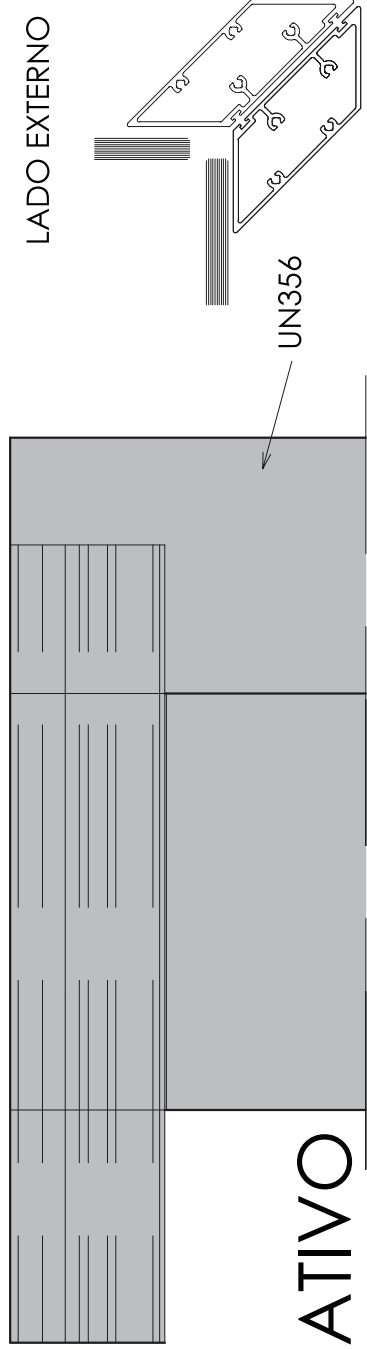

CANTO NEGATIVO

Módulo 100 Encaixilhado

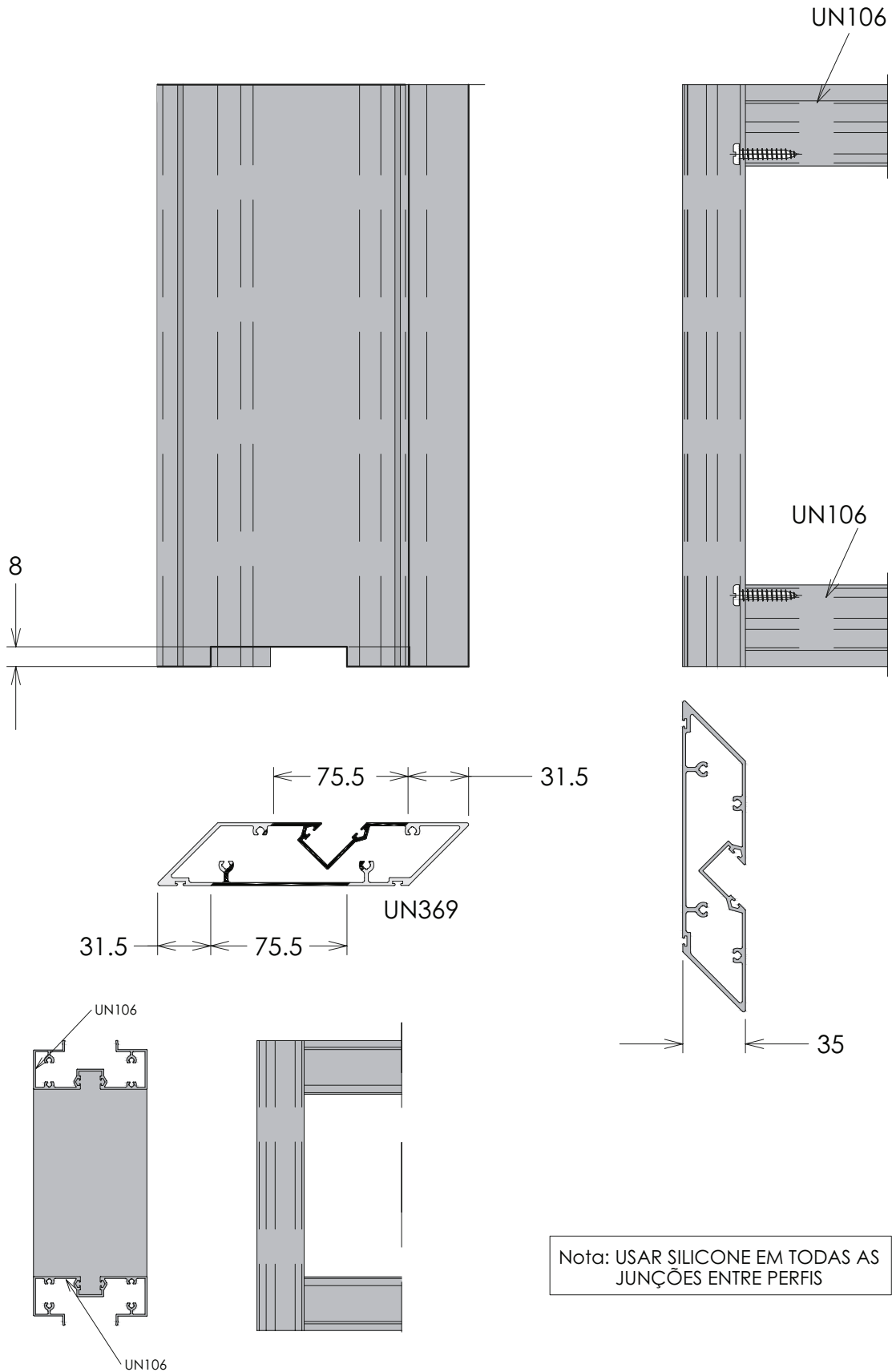

Nota: USAR SILICONE EM TODAS AS JUNÇÕES ENTRE PERFIS

Módulo 100 Encaixilhado

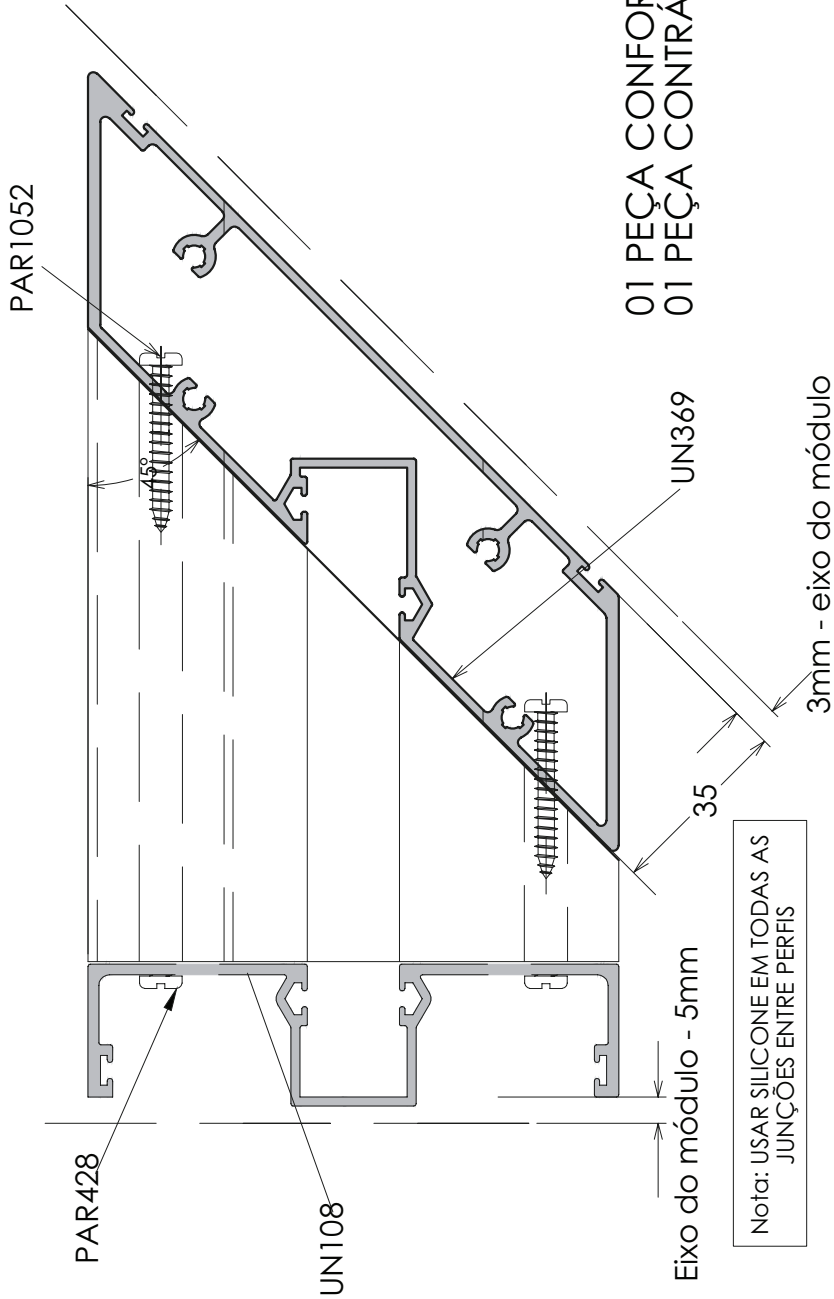
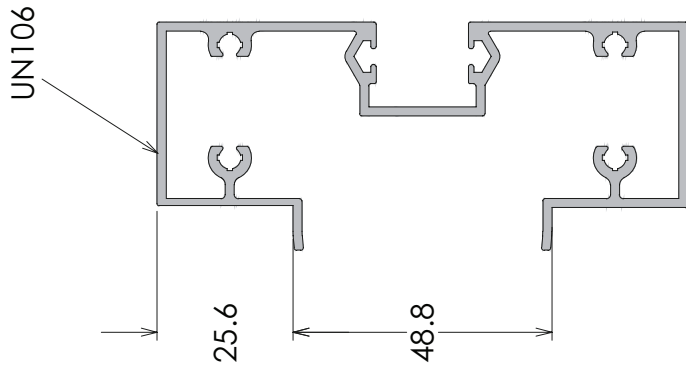

LADO EXTERNO

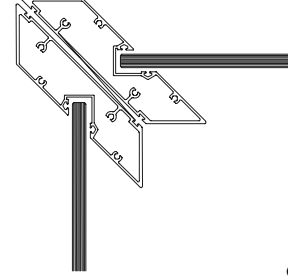

UN369

CANTO POSITIVO



Módulo 120-35

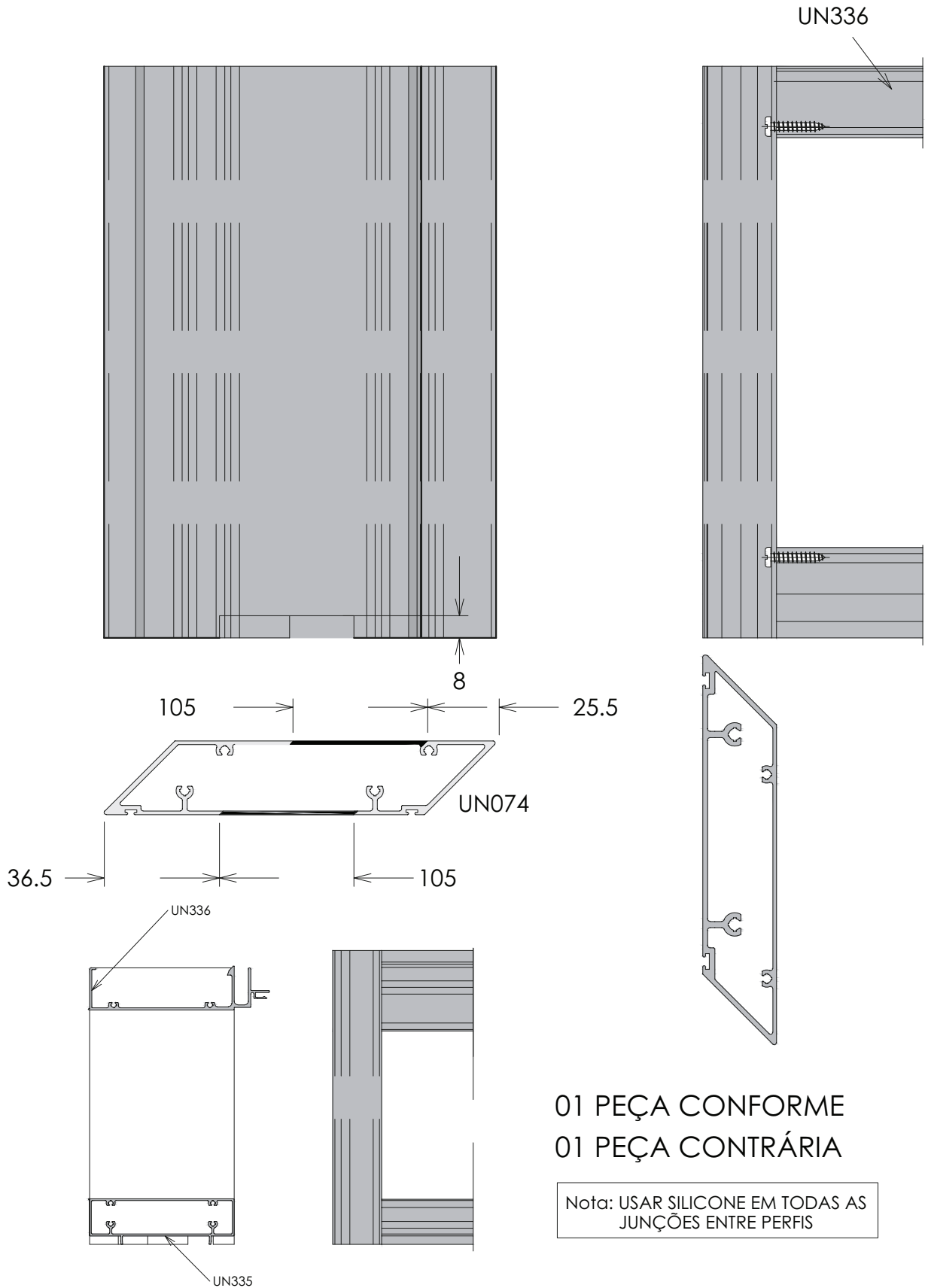

01 PEÇA CONFORME
01 PEÇA CONTRÁRIA

Nota: USAR SILICONE EM TODAS AS
JUNÇÕES ENTRE PERFIS

Módulo 120-35

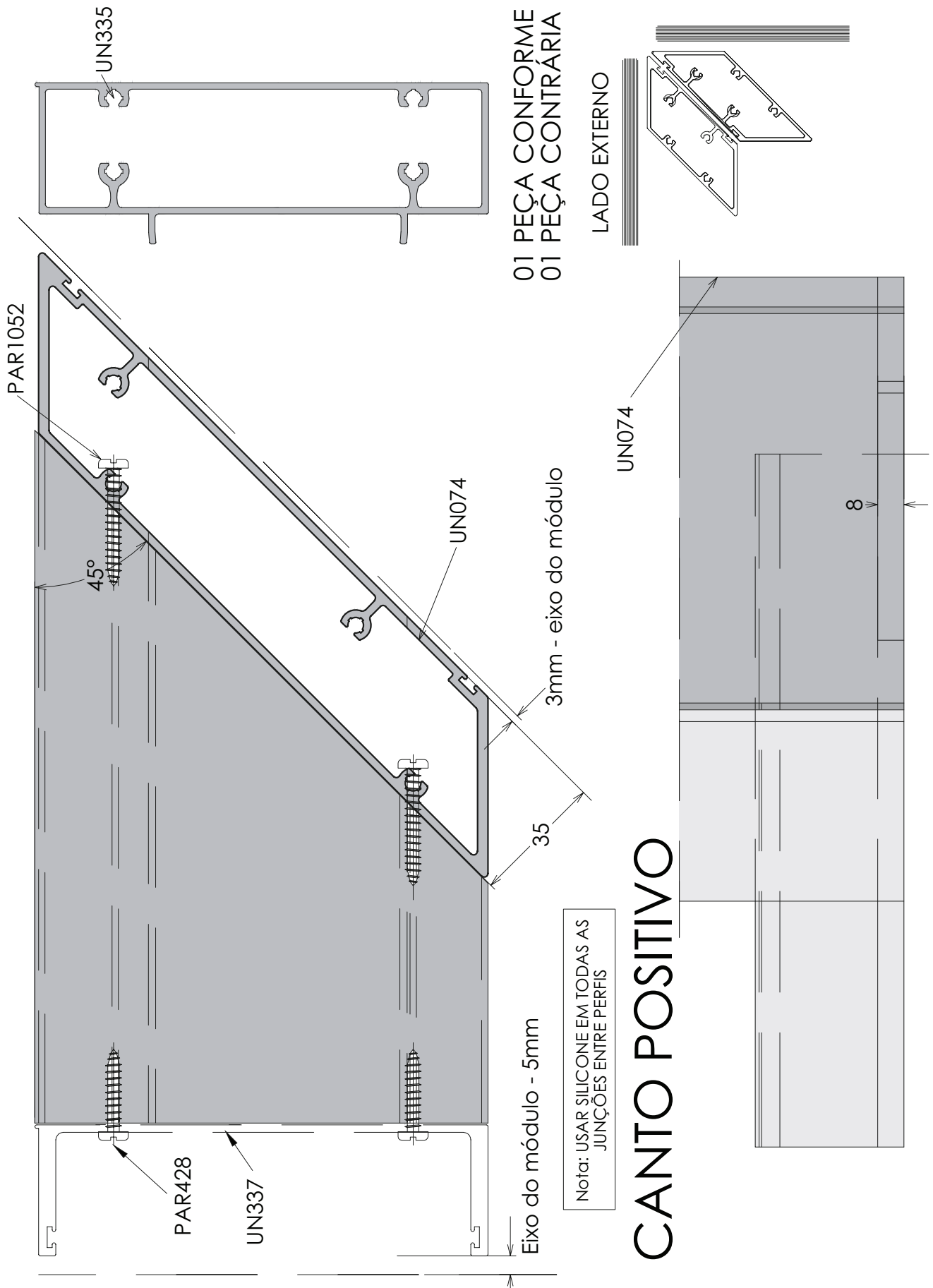

01 PEÇA CONFORME
01 PEÇA CONTRÁRIA

LADO EXTERNO

CANTO POSITIVO

Nota: USAR SILICONE EM TODAS AS JUNÇÕES ENTRE PERFIS

Módulo 120-35

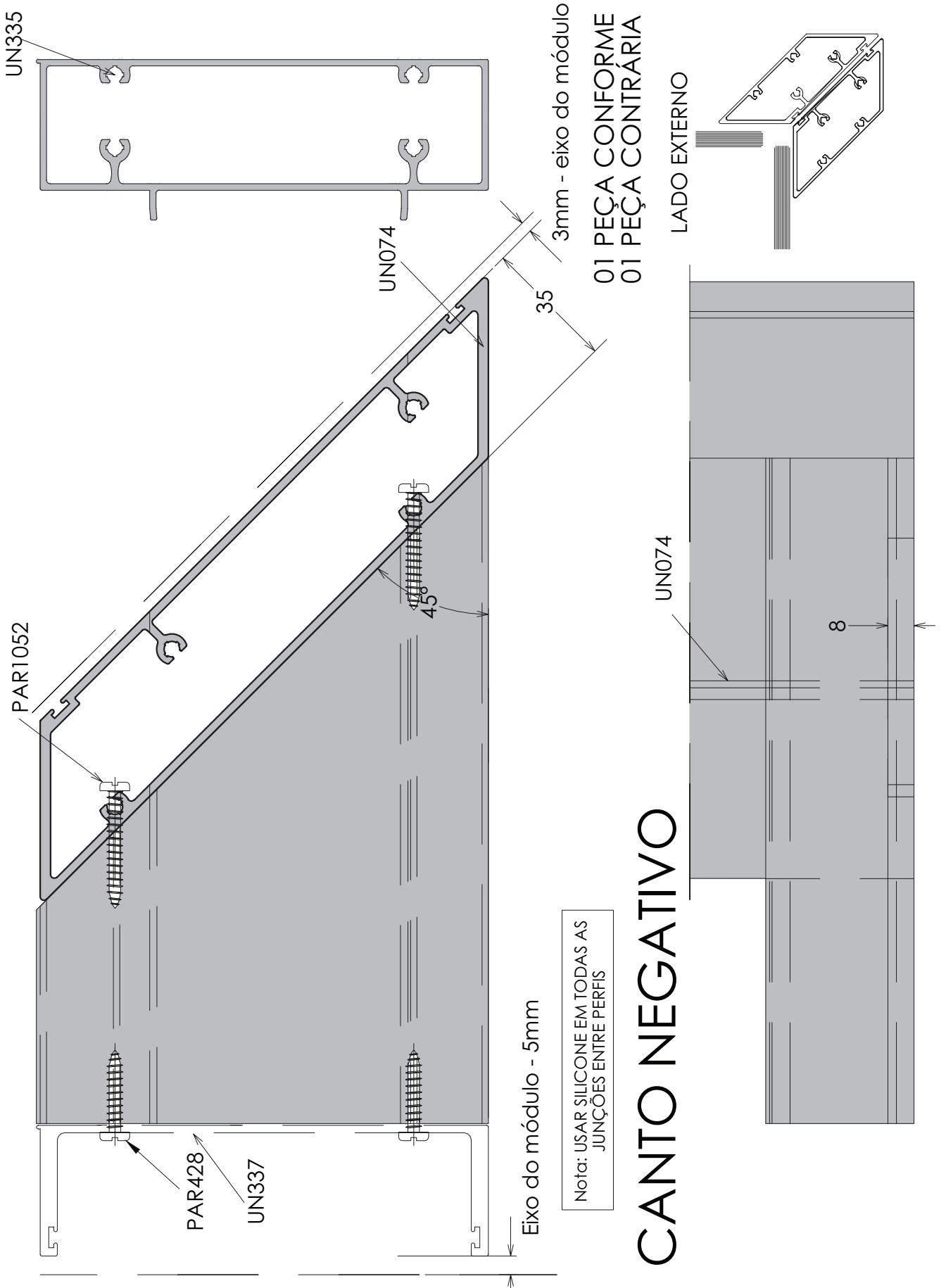

Módulo 120-35

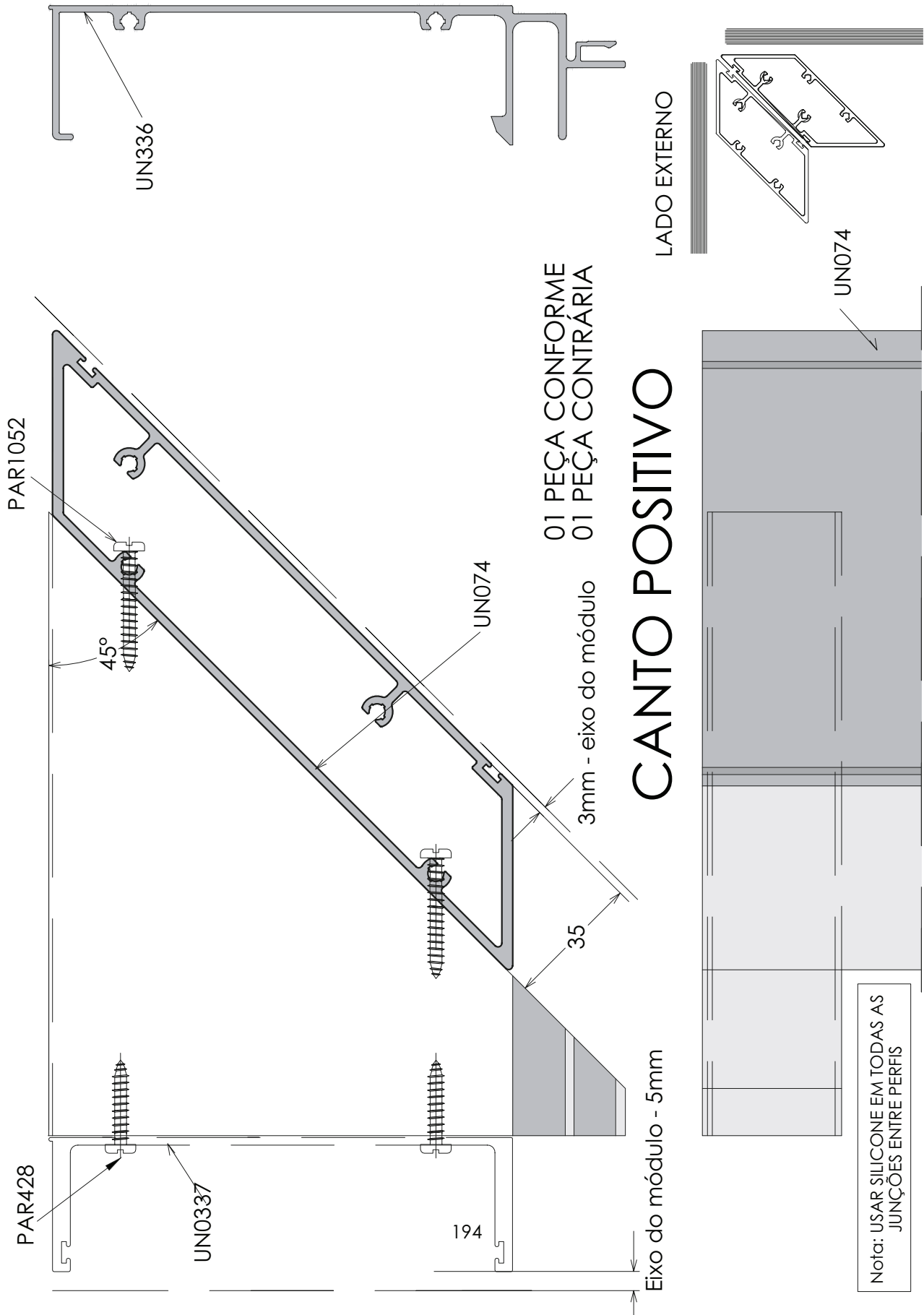

Módulo 120-35

CANTO NEGATIVO

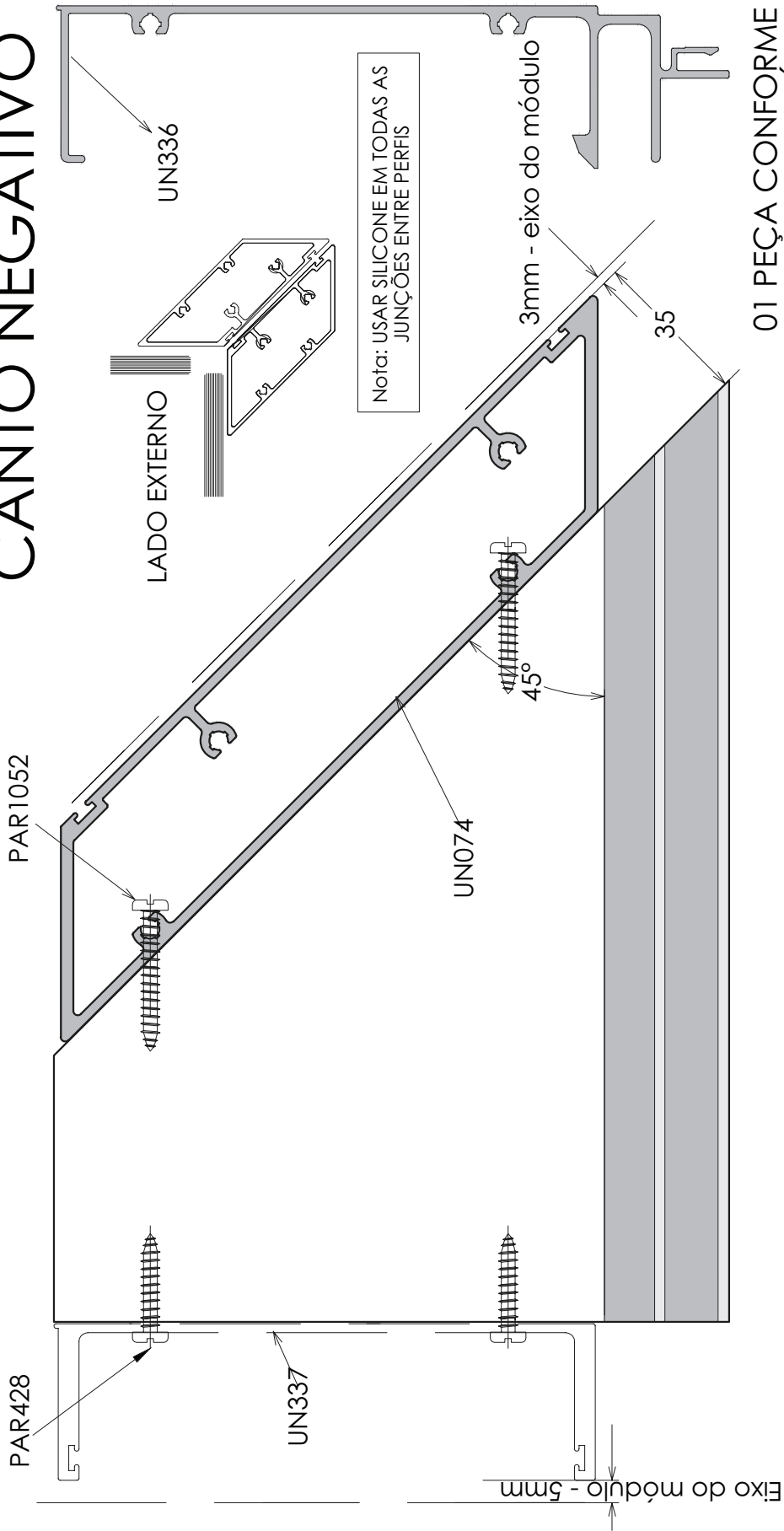

01 PEÇA CONFORME
01 PEÇA CONTRÁRIA

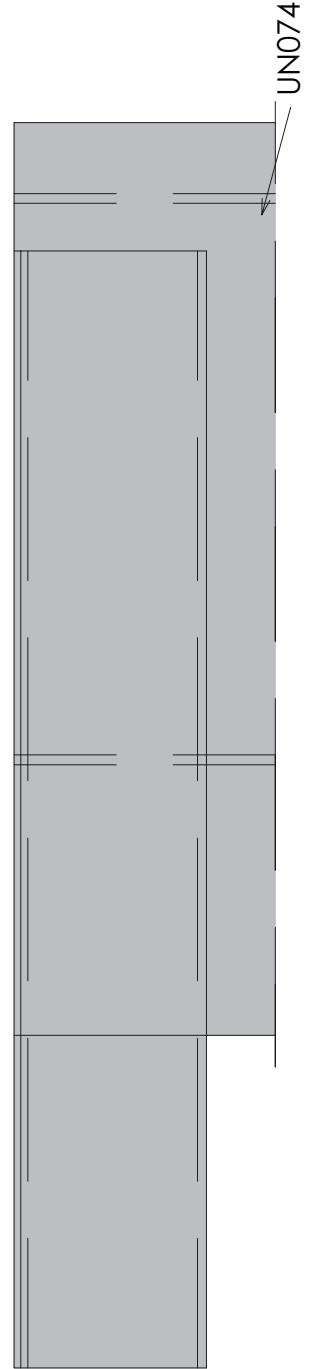

Módulo 120 Fix. Contínua

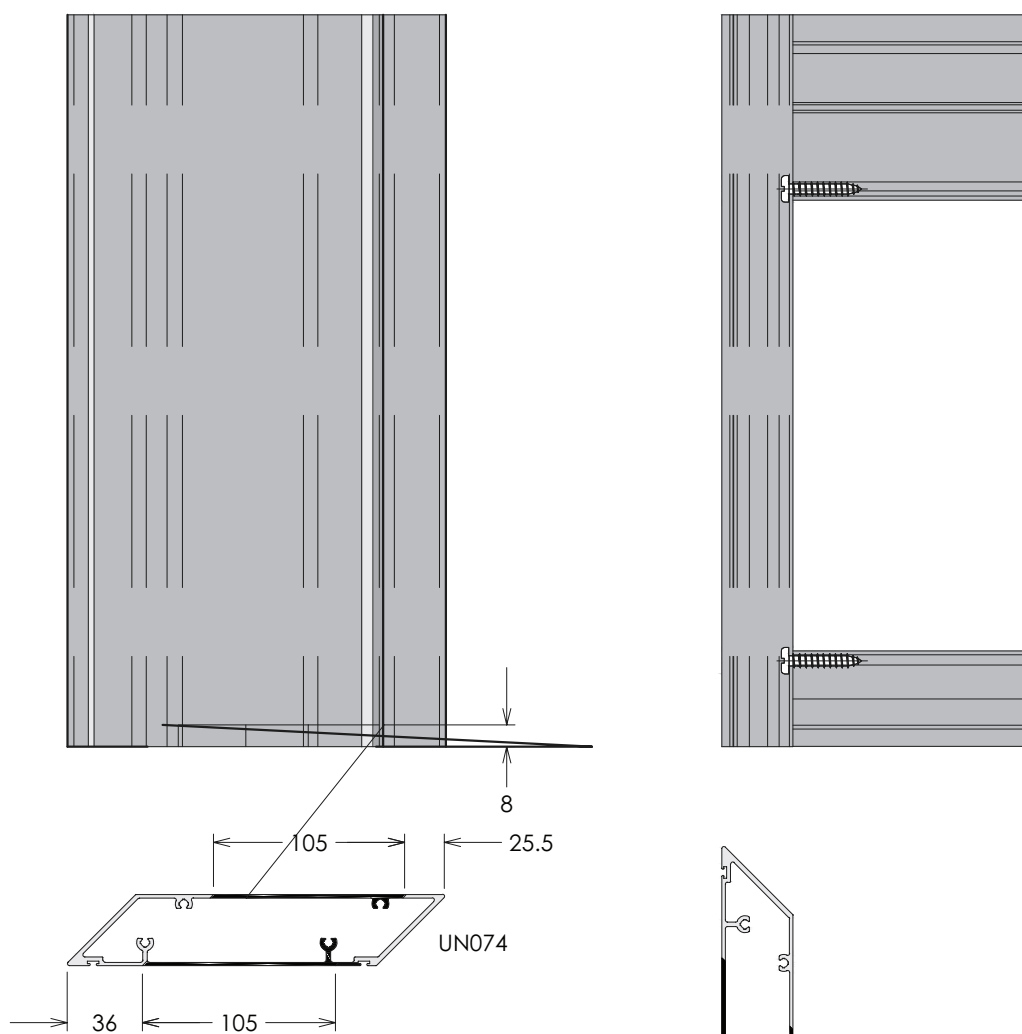

01 PEÇA CONFORME
01 PEÇA CONTRÁRIA

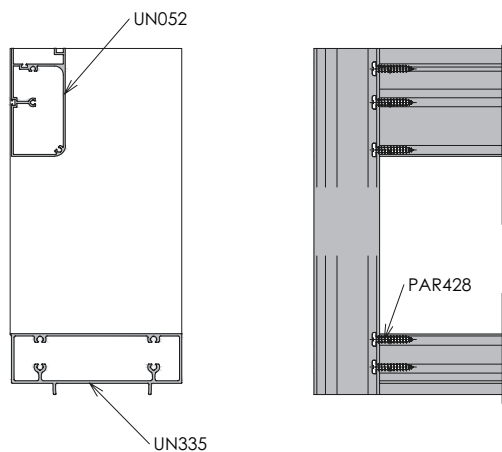

Nota: USAR SILICONE EM TODAS AS
JUNÇÕES ENTRE PERFIS

Módulo 120 Fix. Contínua

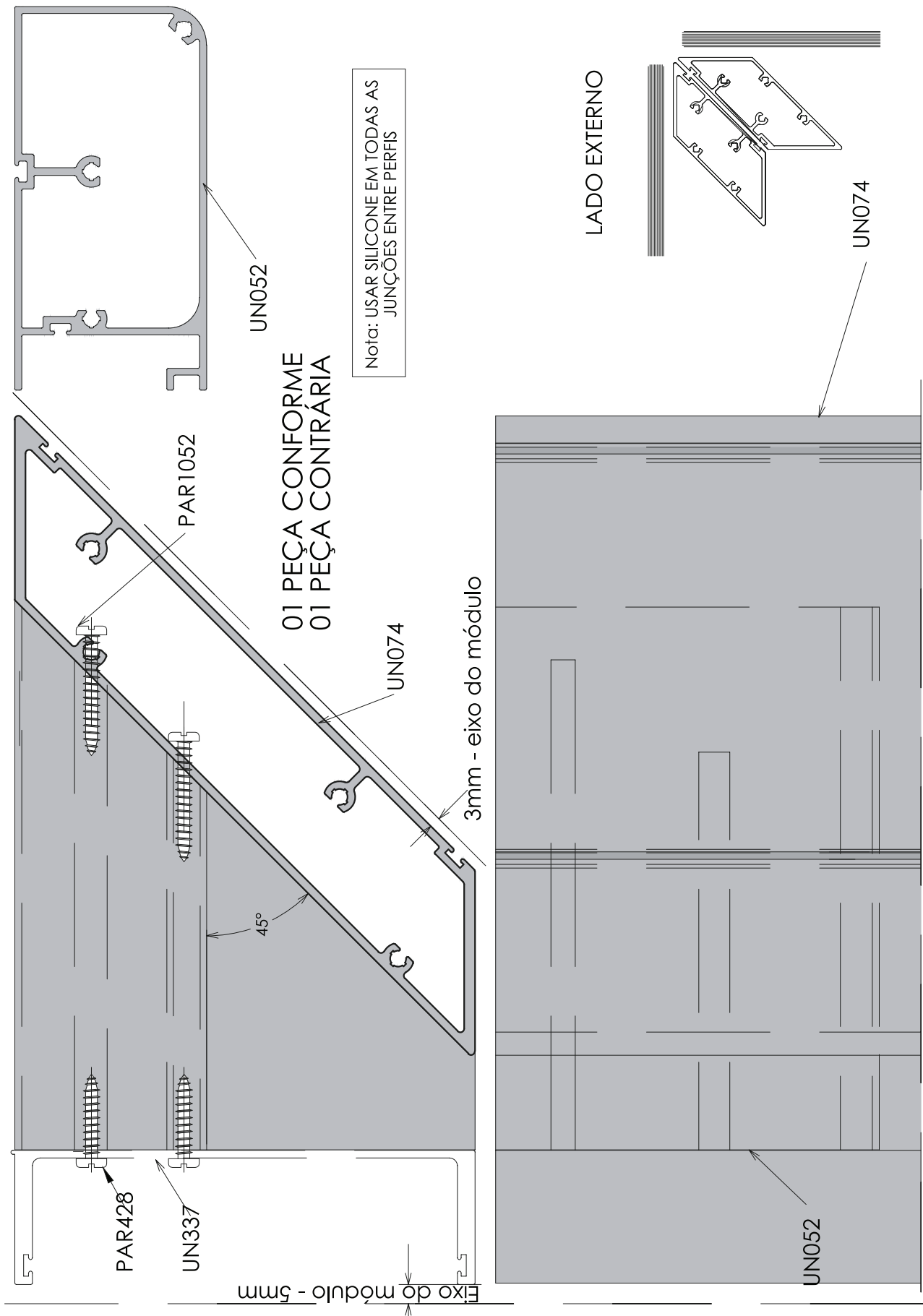

Módulo 120 Fix. Contínua

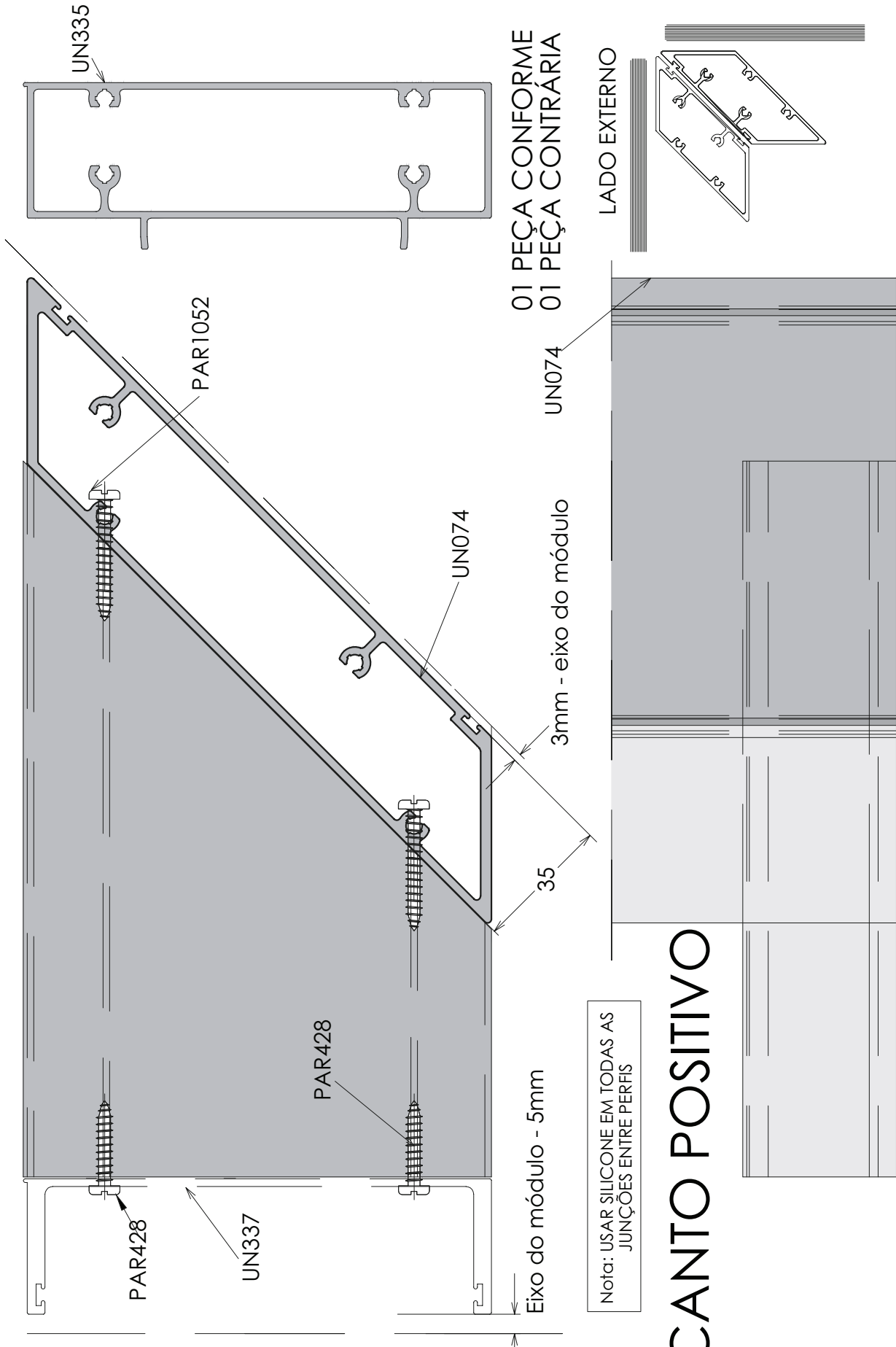

Módulo 120 Fix. Contínua

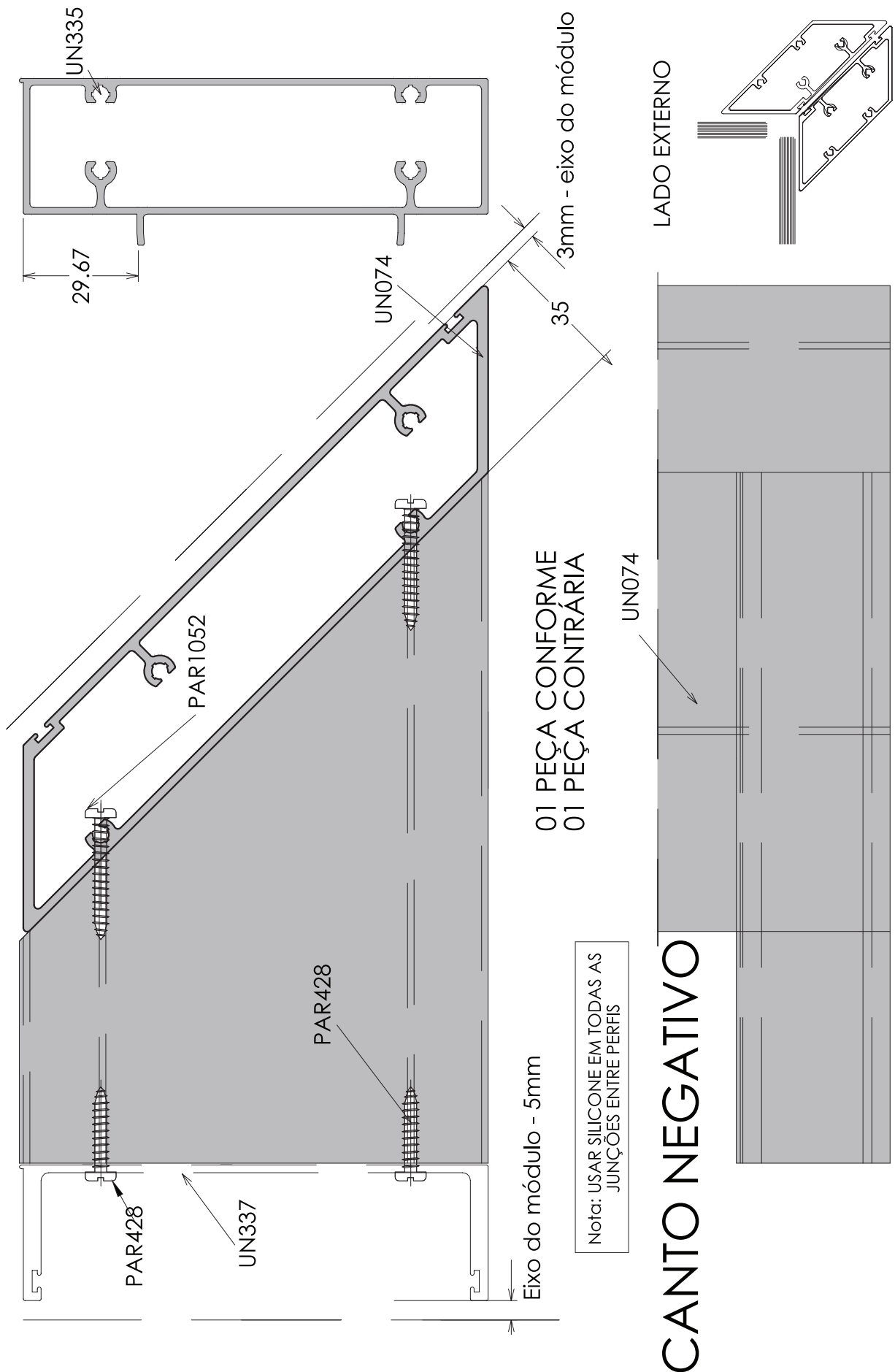

Usinagens

Canto positivo

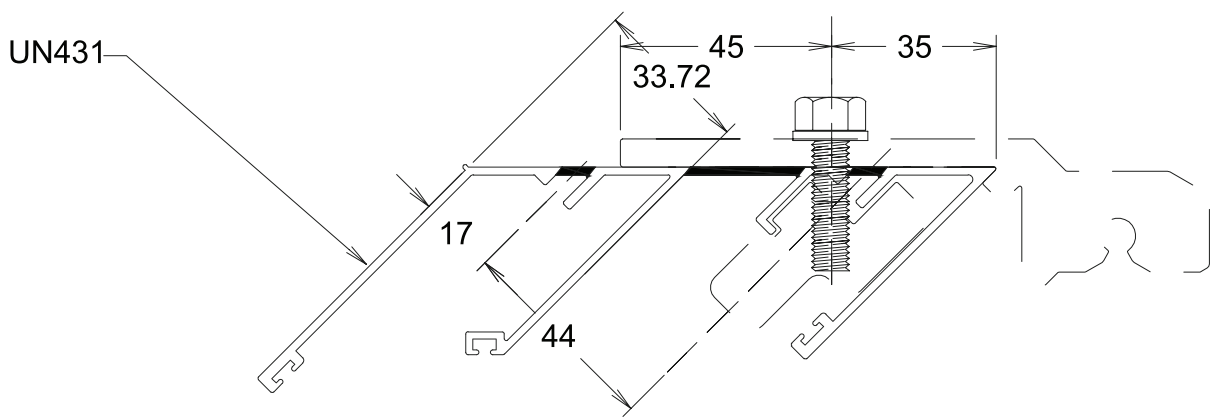

Esta medida será definida de acordo com tipo de tirante e condições dos níveis na obra.

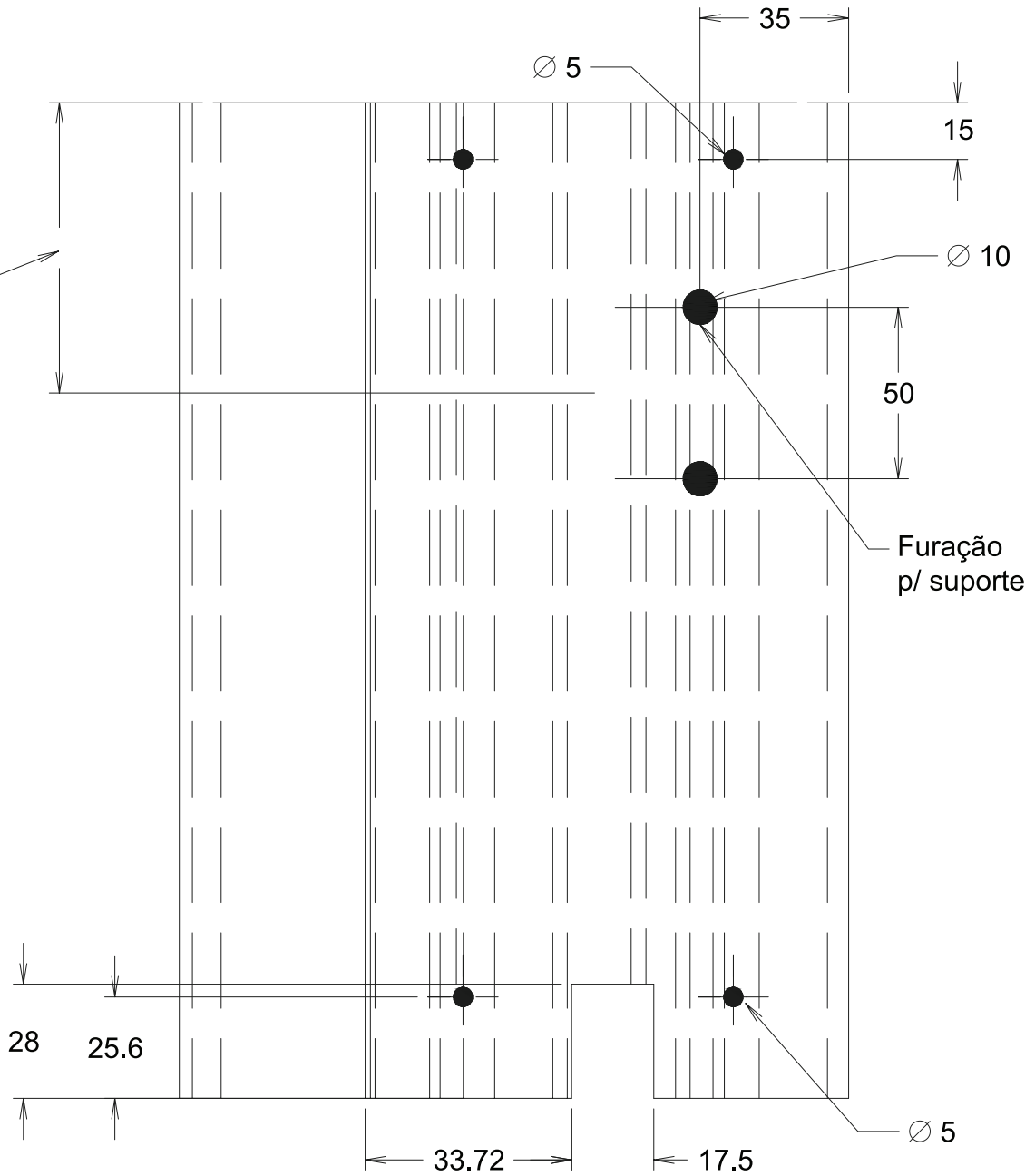

Usinagens

Canto positivo

Furo p/ passagem do parafuso e chave Phillips

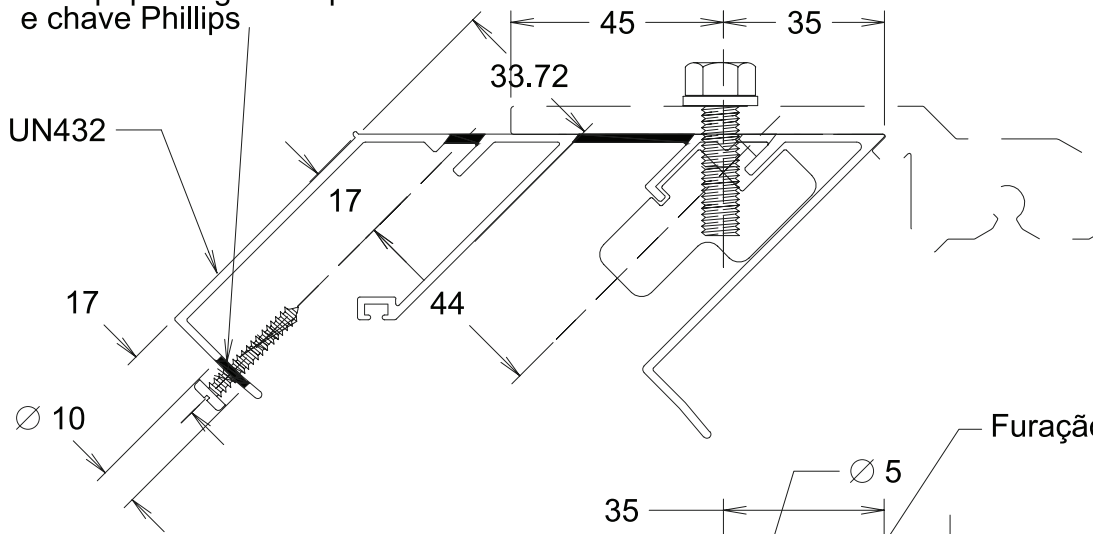

Furação p/ suporte

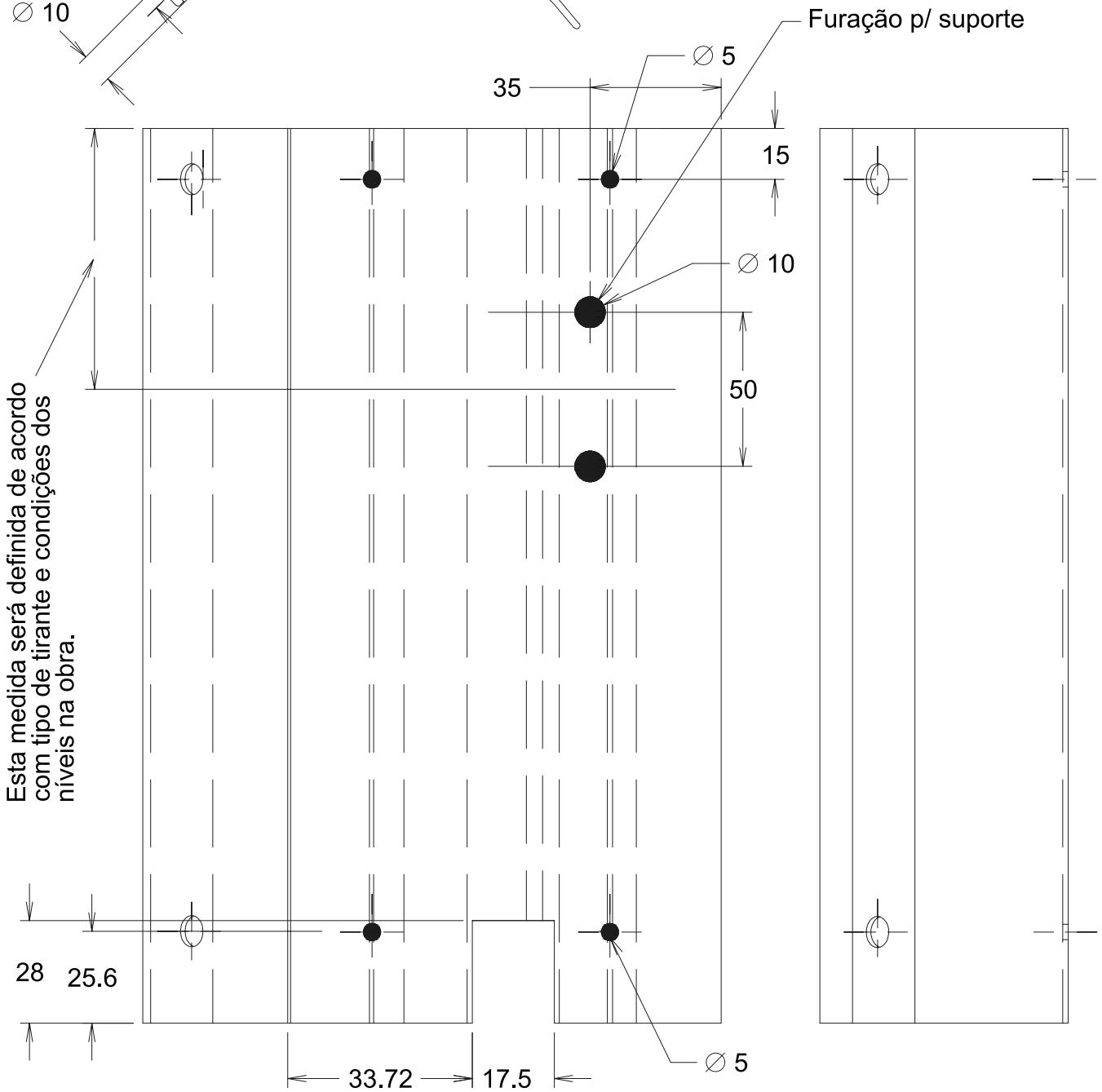

Módulo 120-35

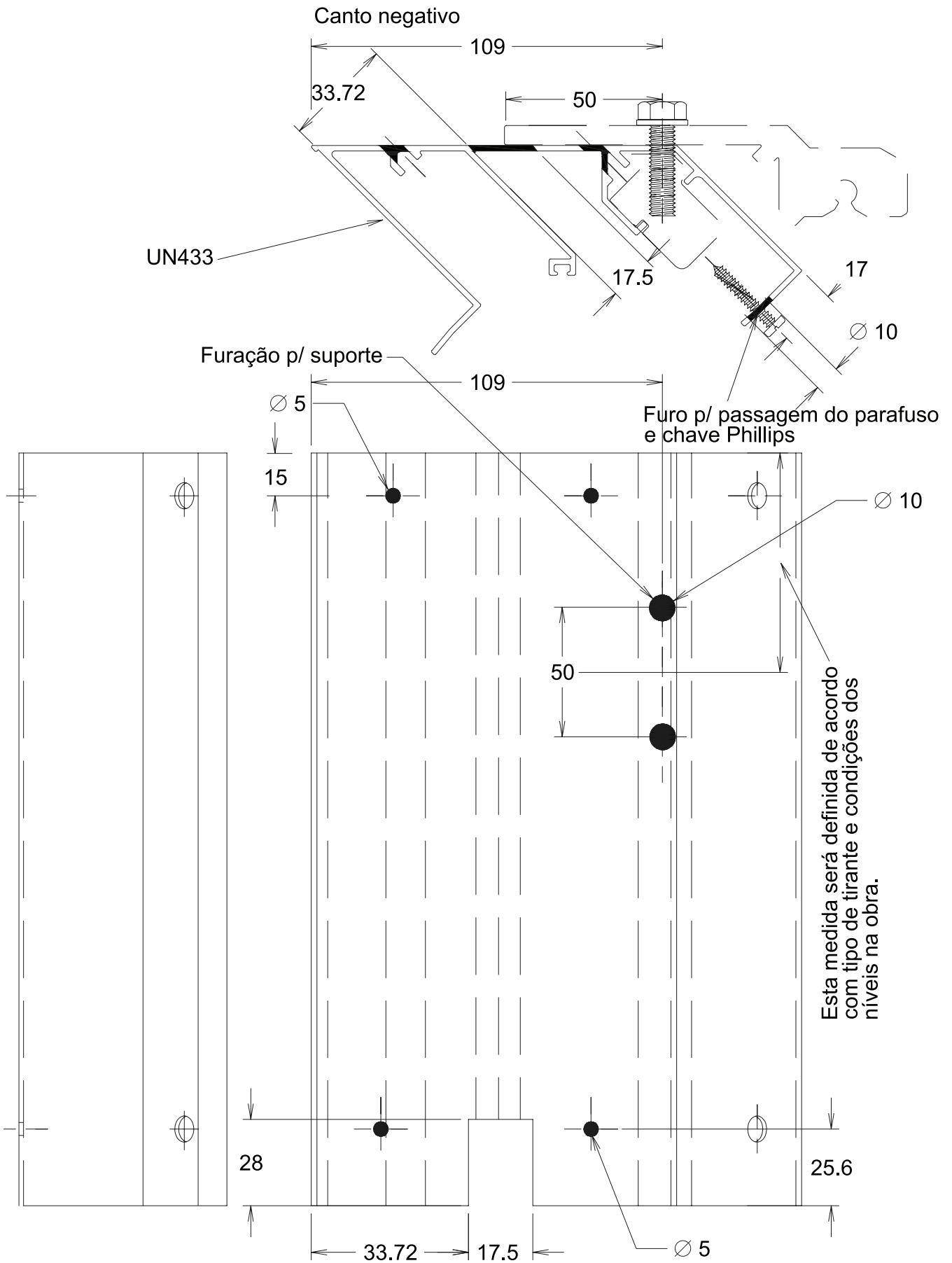

Módulo 120 Fix. Contínua

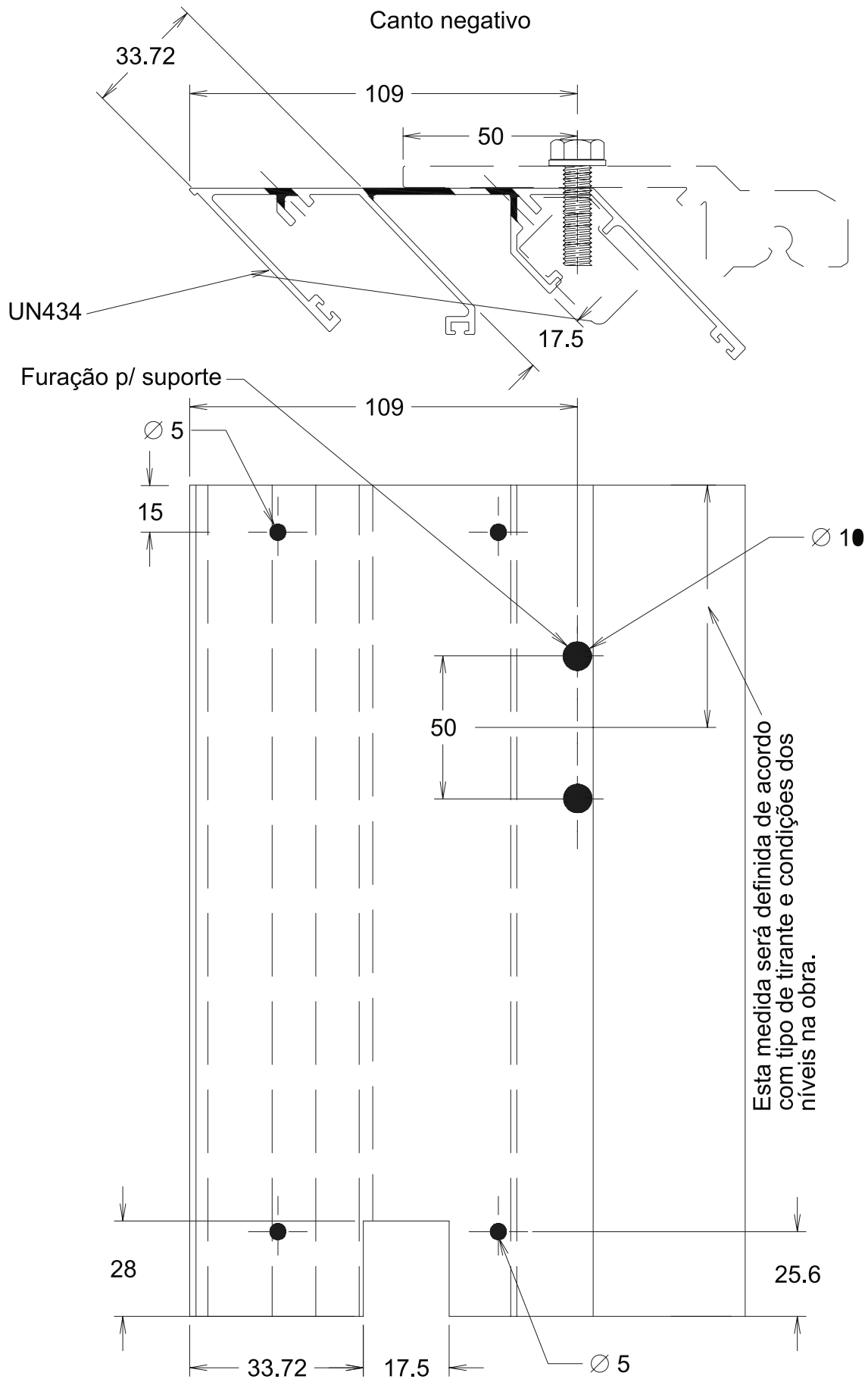

Componentes

Vedação do furo p/ passagem do parafuso

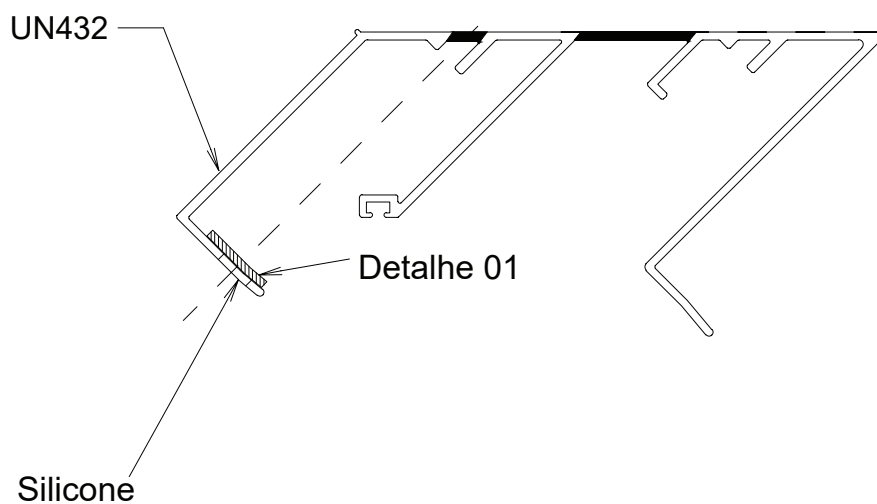

Detalhe - 0 1

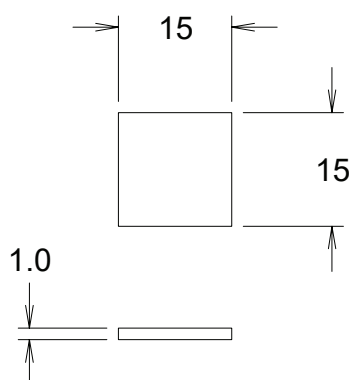

Material - GUA384

Padrão para todos os módulos

Usinagens

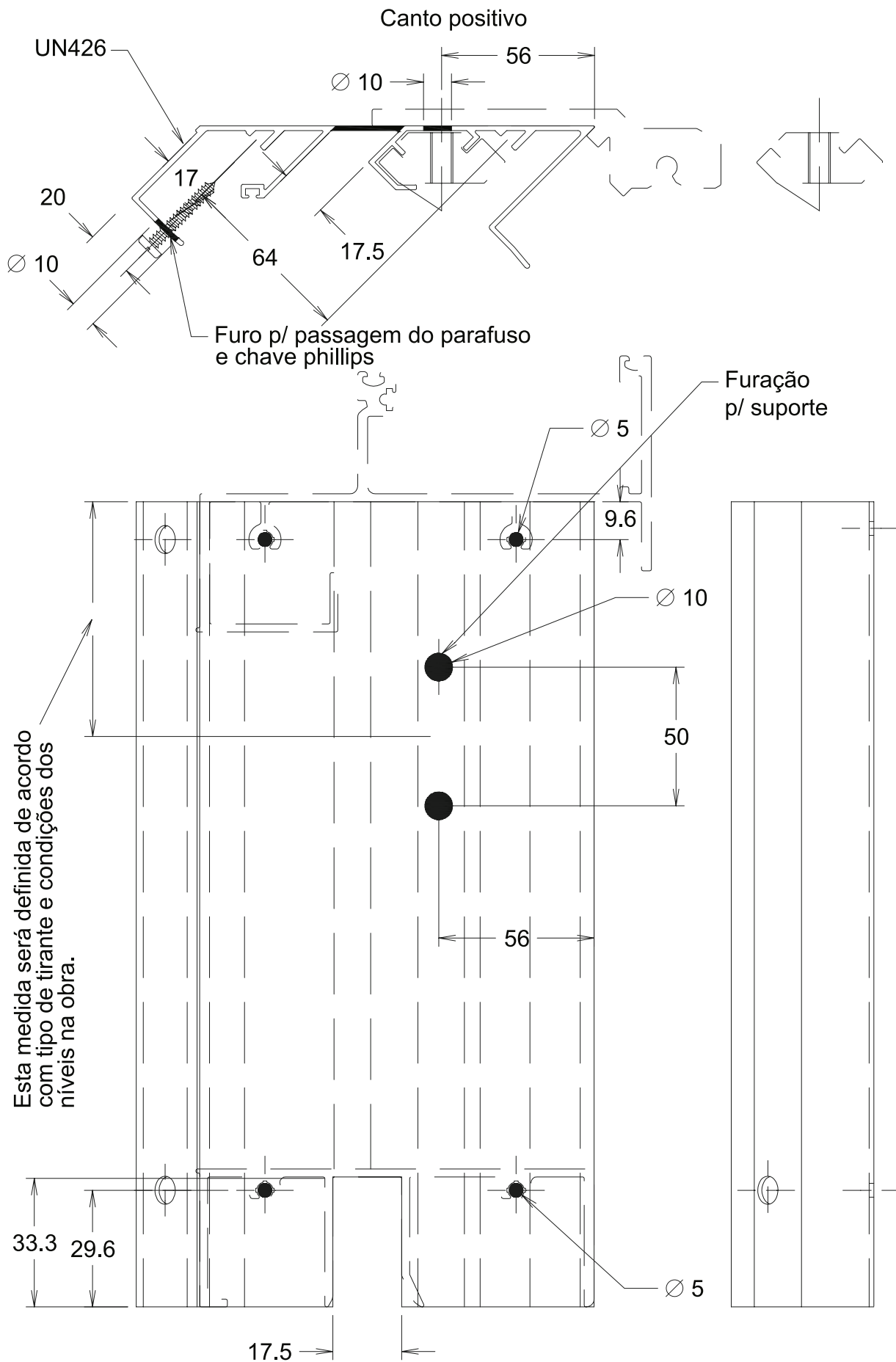

Usinagens

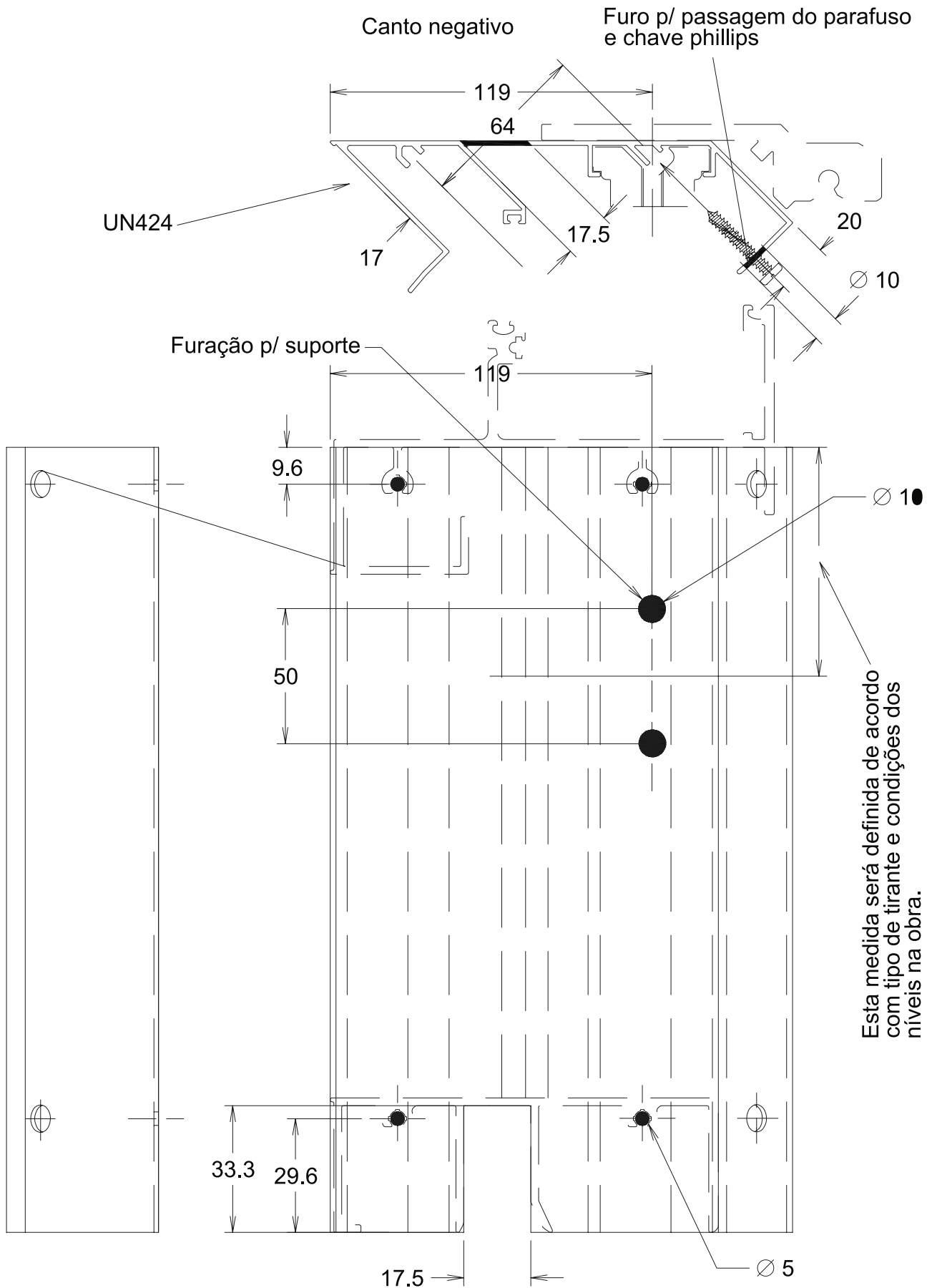

Usinagens

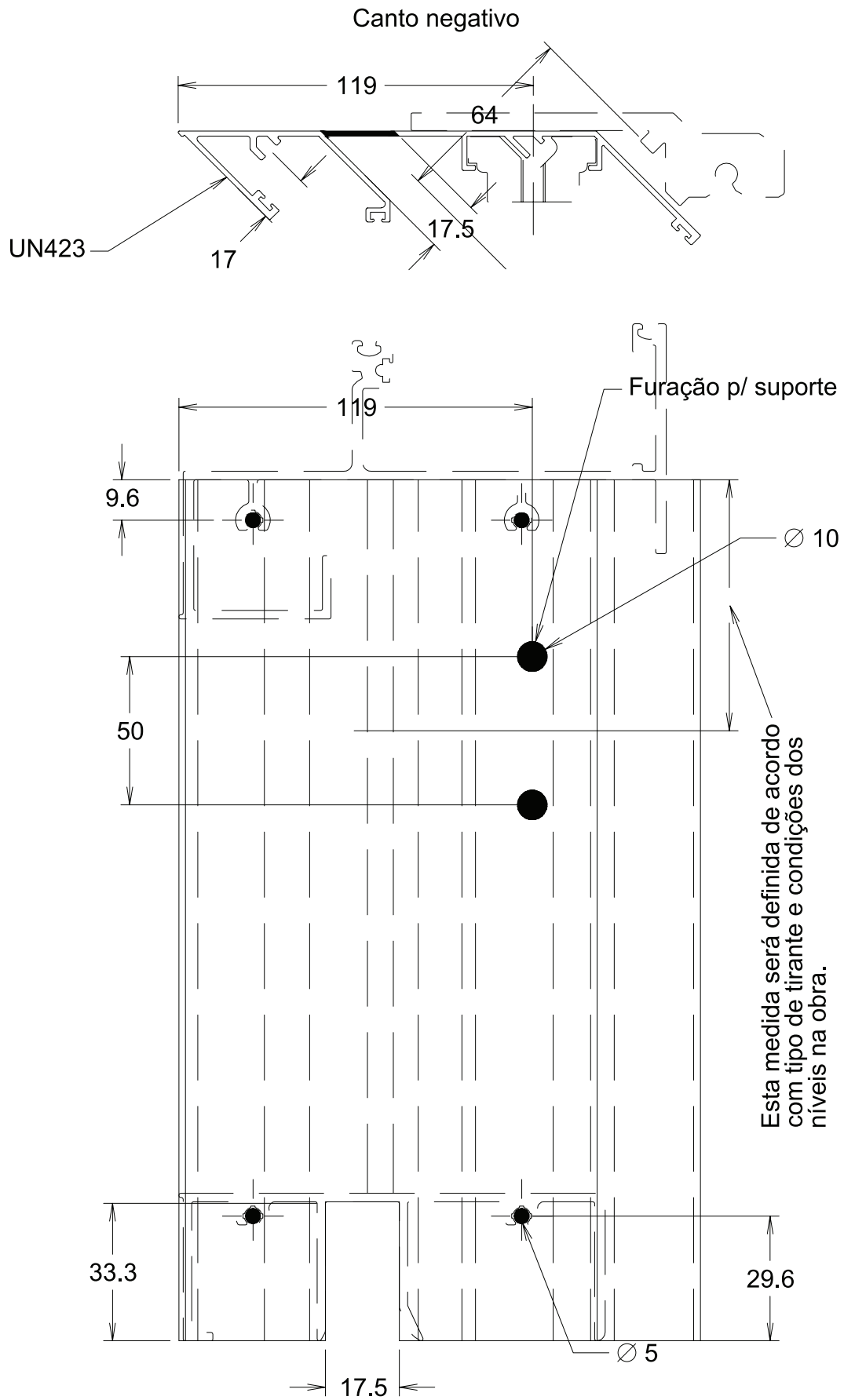

Componentes

Vedação do furo p/ passagem do parafuso

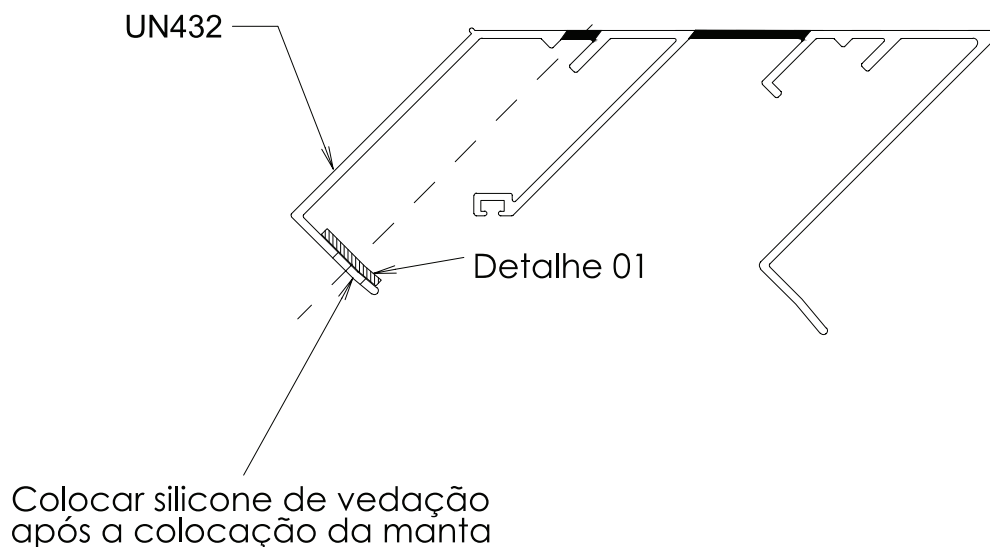

Detalhe - 01

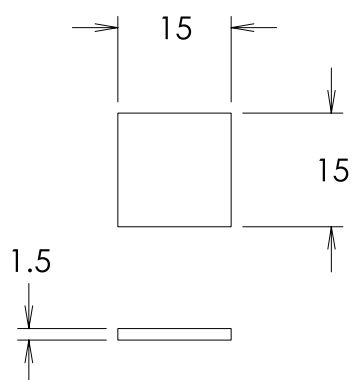

Material - Manta de EPDM ou Silicone

Padrão para todos os módulos

Usinagens

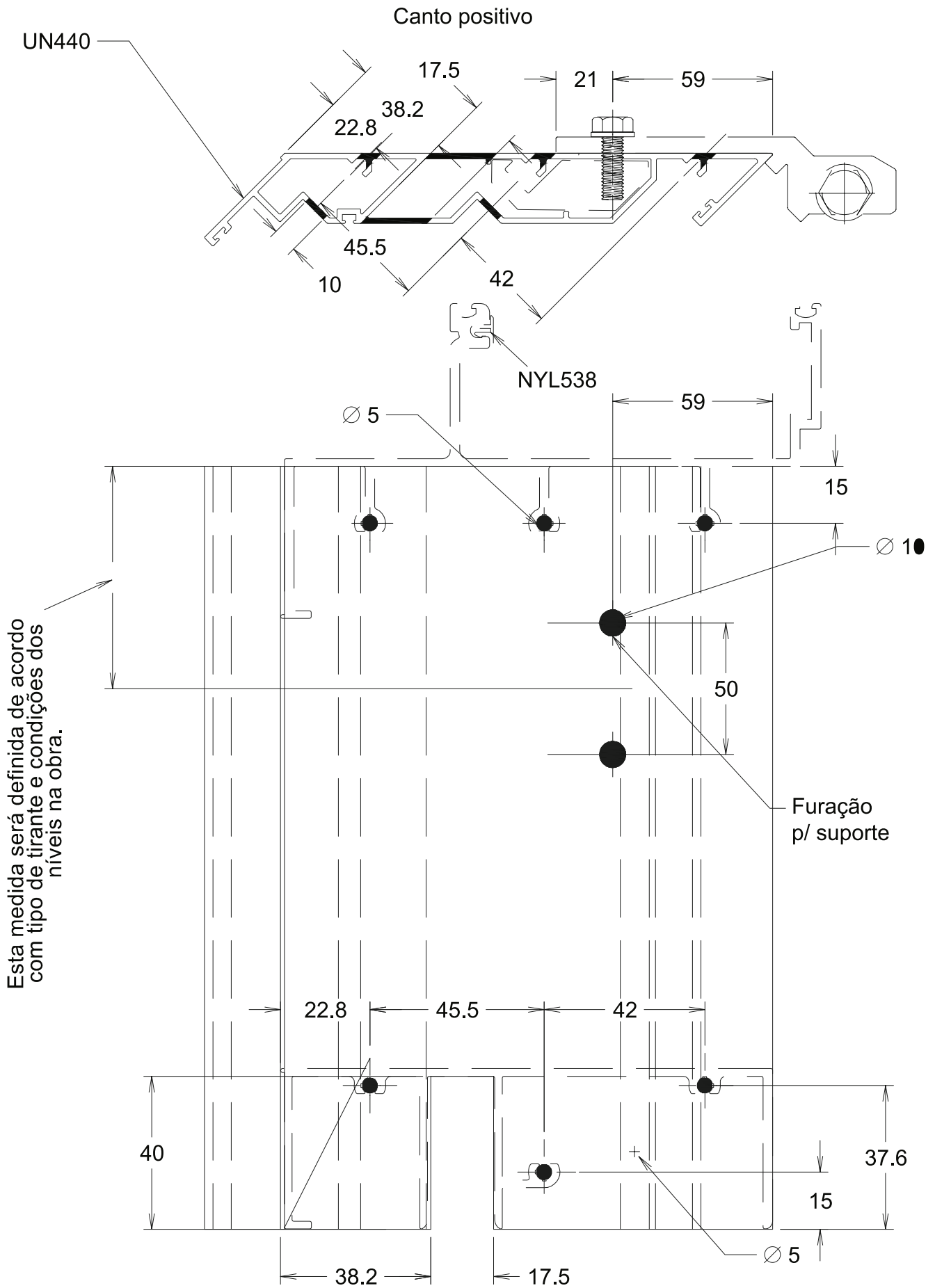

Usinagens

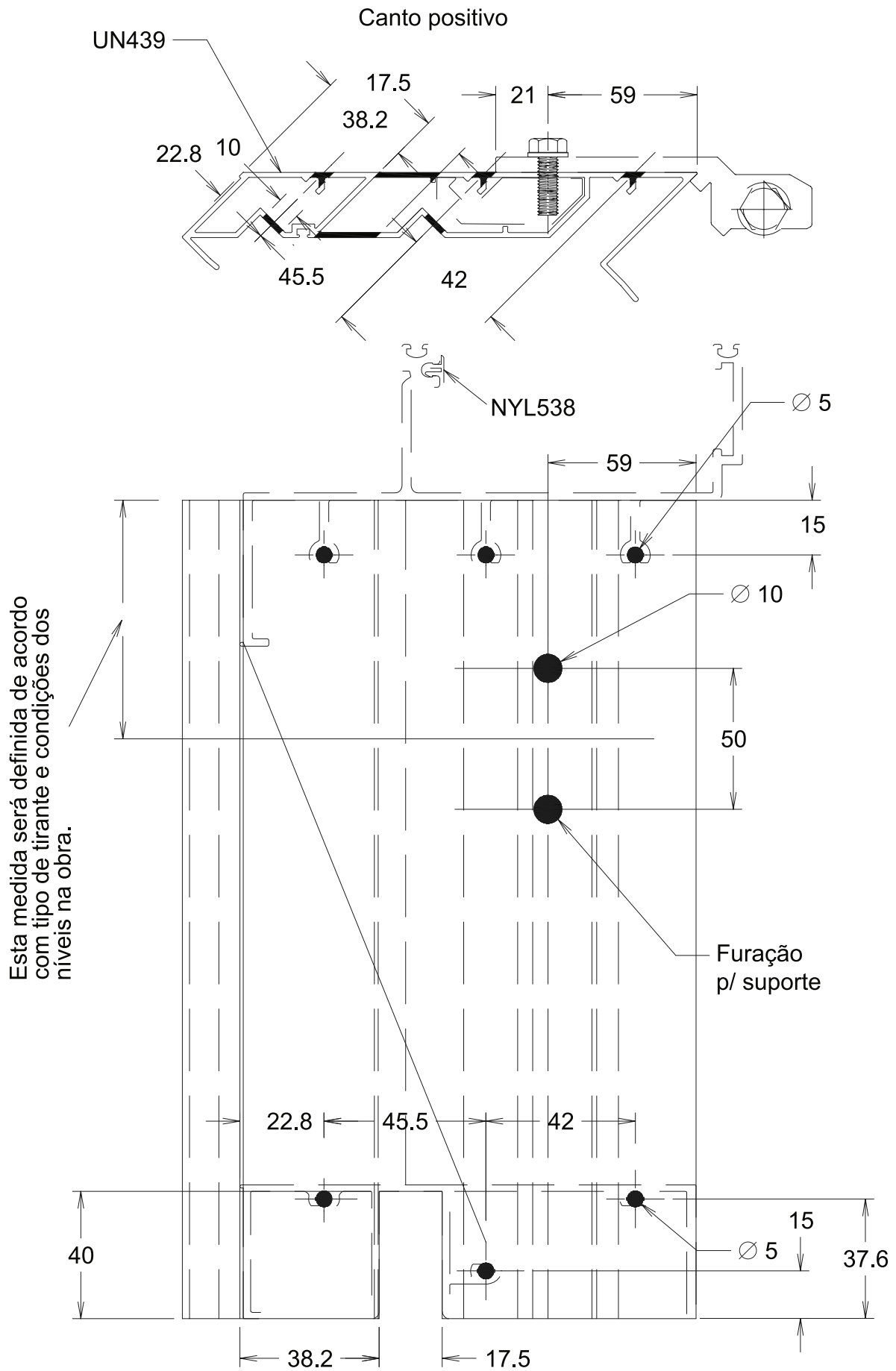

Usinagens

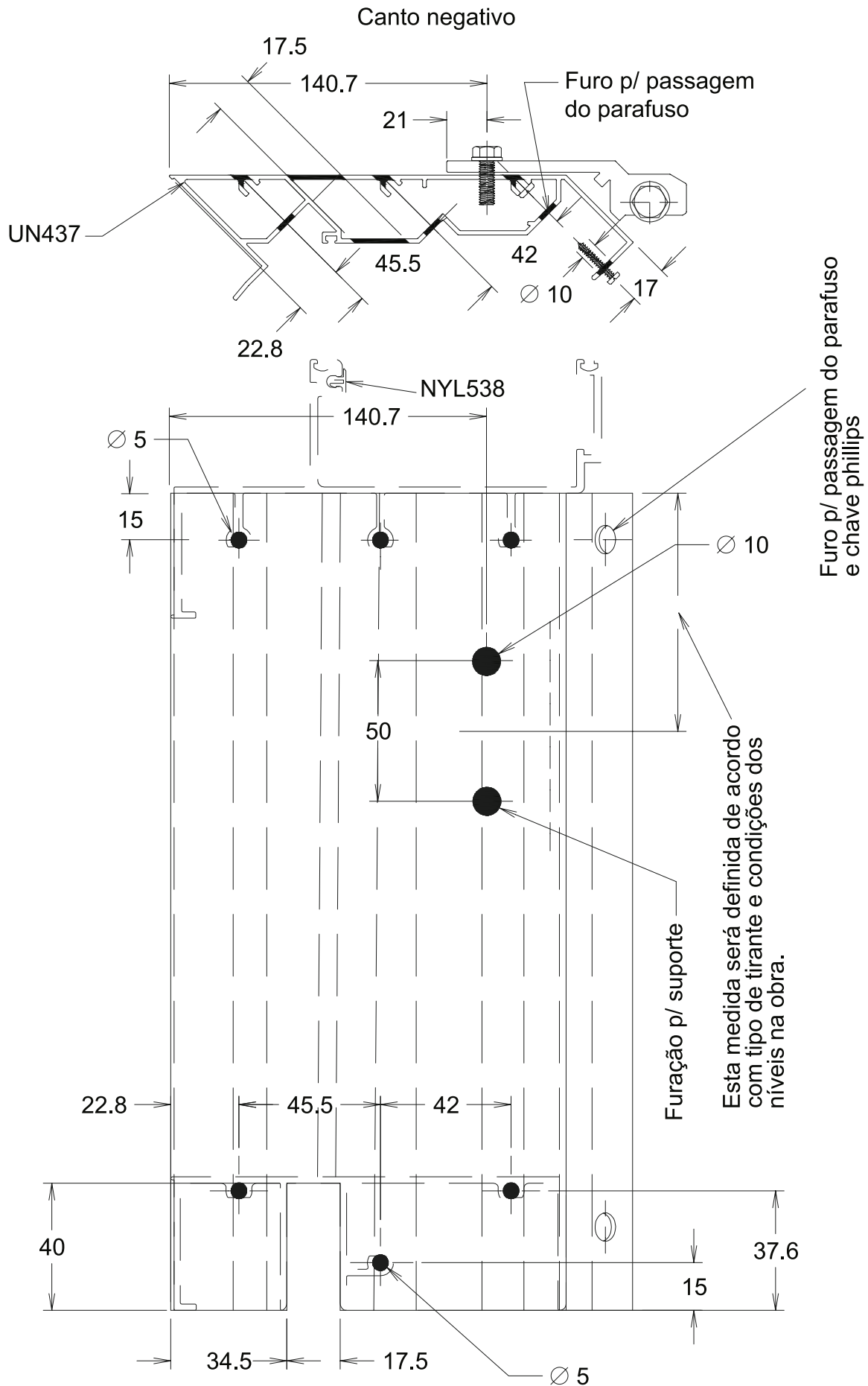

Usinagens

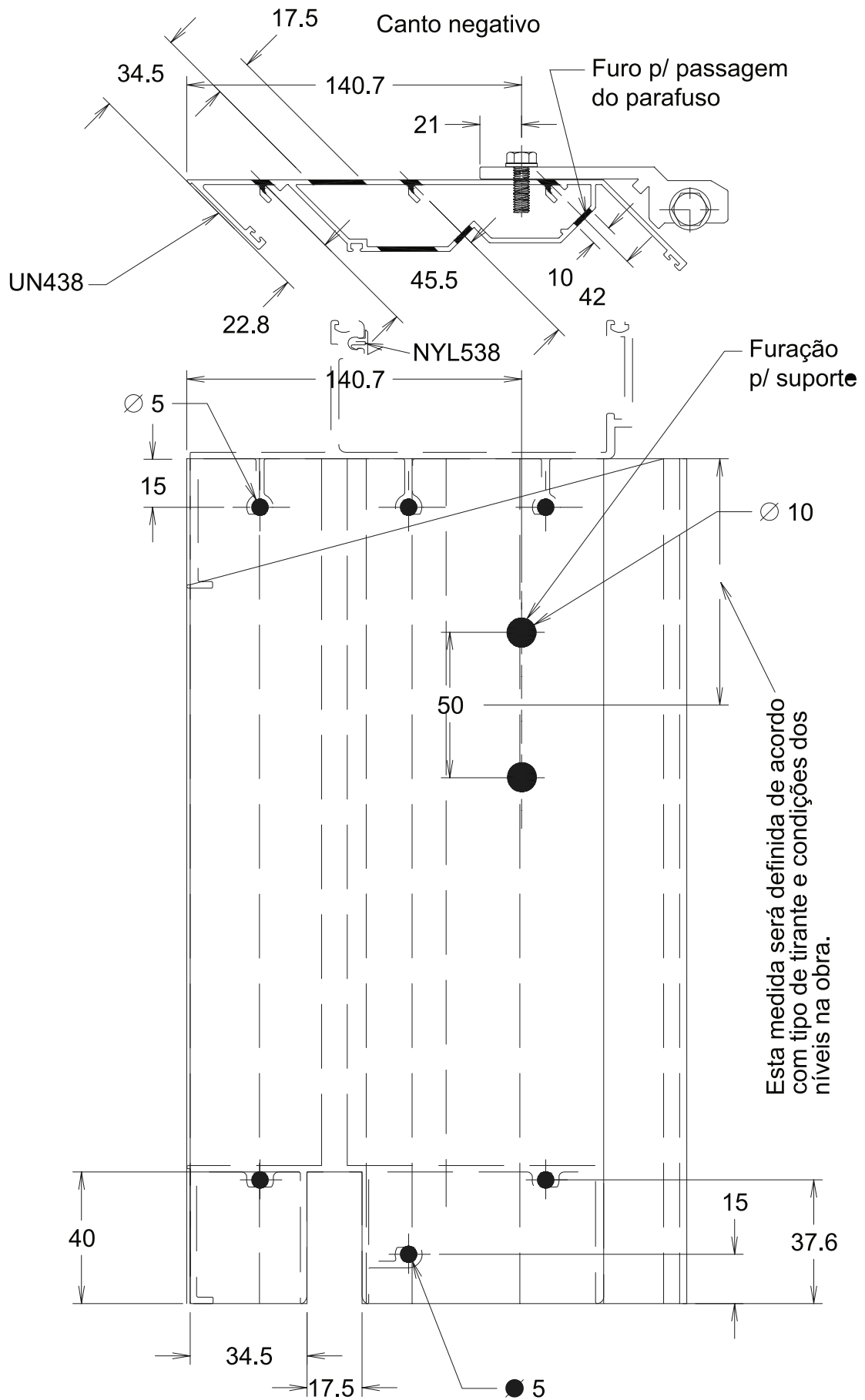

Componentes

Vedação do furo p/ passagem
do parafuso

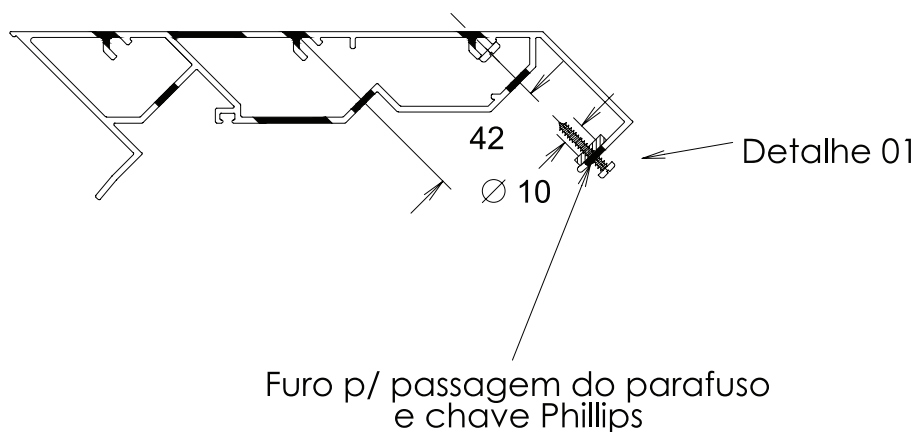

Detalhe - 01

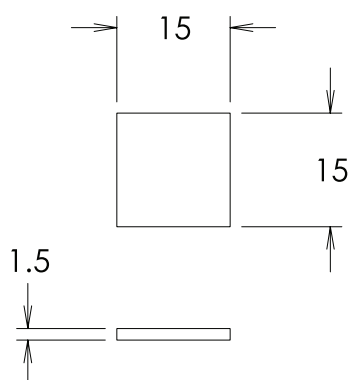

Material - Poliuretano de células fechadas
com uma face adesiva

Padrão para todos os módulos



Catálogo Unit®
Edição 01
www.hydro.com

